

# Tooling by DIJET®

## ミーリング&ドリリング編

# 流通在庫品

■ホソイチッパーS	
SHC形	814
■ホソイチッパー	
HCLS-1形/HCSS-1形	818
HCSK-2形/HCLK-2形	819
HCLT-2形/HCST-2形	820
HCLT-1形/HCLT-2形	821
HCSS-1-BT形/HCSS-2-BT形	822
HCLT-2-BT形/HCST-2-BT形	823
■エンドチッパー	
ECSPR-1形/ECSPR-2形/ECZPR-1形	824
ECZPR-1-BT形/ECSPR-1-BT形	826
ECSPR-2-BT形/SL-ECSPR-1形/XL-ECSPR-1形	828
SL-ECSPR-2形/XL-ECSPR-2形	830
■スウィングミル・ミニ	
DSM-M形	831
■Rチッパー	
RCPR-1-BT形/RCPR-2-BT形/ZPR-020形	832
■柄付きカッタ	
HR2L-0203形(アルミ加工用)/PNS-0203形	835
LC90P-0203形/ZNP90S-0203形/ACTPR形	836
■その他カッタ	
HSG45-5000形/ HR2L形(アルミ加工用)/PNS形/ZNP45M形	838
■DZコートソリッドエンドミル	
DZ-DES2-S形/DZ-DES2-L形	841
■DXコートソリッドエンドミル	
OCES2-S-D形/OCES2-L-D形	843
OCES4-S-D形/OCES4-L-D形	847
OCKS-P-D形/OCKS-M-D形	854
■アルミ加工用ソリッドエンドミル	
OCAS1-L形	851
OCAS2-S形/OCAS2-L形/OCAS2-L45形	852
■ノンコートソリッドエンドミル	
OCES2-S形/OCES2-L形/OCES4-S形/OCES4-L形	849
OCKS-P形	854
DYK5-形/SED-C形	855
SCEL形/SCSE形/EXL-E2形/EXL-E4形	856
LS-OCFS2形/LS-OCFS4形/XLS-E2形/XLS-E4形	858
OCFS2-M形/OCFS2-S形/OCFS2-L形	860
OCFS4-L形/OCFS4-S形	862
SED-R形/PS-SED形	863
DYK-6形/DYK-7形	864
DES2-S形/DES2-L形	866
■付け刃エンドミル	
OCEB形/OCEB-C形/OCEB-S形	868
OCL形/OC-L形	872
SPC形/SPC-L形	881
HSP4-EL形/HSP6-LT形	886
DT-BS形/DT-MT形	887
■JBNソリッドボールエンドミル	
JBN-BE形	889
■DZコートソリッドボールエンドミル	
DZ-DBPS形	890
DZ-DBSS-S形/DZ-DBSM-S形	890
DZ-TSBS-R形	891
■DXコートソリッドボールエンドミル	
SBEL-R-D形/DBS1-D形	892
■ノンコートソリッドボールエンドミル	
GF-SBX形/GF-SBR形/GF-SBL形	893
DYBS-S形/DYBS-L形	895
DYK-2形/DYK-1形	896
SCBE-2形/LN-SBEL-R形/LS-SBE-R形	897
SBEL-R形/SBEL-R-S形/SBEL-R-T形	898
DYBS-M形/ESL-SBE形/TSBS-R形/TSBL-R形	900
DYK-3形/DYK-4形	902
■付け刃ボールエンドミル	
BE-R形/BE-A形/LS-BE-R形	903
■穴あけ工具	
VSD形/TIN-VSD形/VSDL形/TIN-VSDL形	905
DTD形/DTD-MT形/DTD-L形	907
TOP-SLD形/TD形/SD形	911
■その他工具	
SDM形/SDFM形/INDS形/DM形	914
■研磨丸棒チップ	920

## ホソイチッパー"S" SHC-S形

- ストレートシャンク形  
2枚刃、2コーナ形



### ■本体

●使用チップ数  
主刃: 1枚  
副刃: 1枚  
外周刃: 2枚

形番 Cat. No.	在庫 Stock	寸法 (mm) Dimensions (mm)						
		R	φD	l	l <sub>1</sub>	l <sub>2</sub>	L	φd
SHCS5060S42	○	25	50	60	100	100	200	42
SHCM5060S42	○				100	150	250	42
SHCL5060S42	○				150	150	300	42
SHCE5060S42	○				150	200	350	42

本体にチップは組込んでありません。

## ホソイチッパー"S" SHC-MT形

- モールステーバシャンク形  
2枚刃、2コーナ形



### ■本体

●使用チップ数  
主刃: 1枚  
副刃: 1枚  
外周刃: 2枚

形番 Cat. No.	在庫 Stock	寸法 (mm) Dimensions (mm)						MT.No.
		R	φD	l	l <sub>1</sub>	l <sub>2</sub>	L	
SHCS5060-MT	○	25	50	60	130	134.5	264.5	MT5
SHCM5060-MT	○				150	134.5	284.5	MT5
SHCL5060-MT	○				180	134.5	314.5	MT5

本体にチップは組込んでありません。

## ホソイチッパー"S" SHC-C形

- コンビネーションシャンク形  
2枚刃、2コーナ形



### ■本体

●使用チップ数  
主刃: 1枚  
副刃: 1枚  
外周刃: 2枚

形番 Cat. No.	在庫 Stock	寸法 (mm) Dimensions (mm)						
		R	φD	l	l <sub>1</sub>	l <sub>2</sub>	L	φd
SHCS5060C508	○	25	50	60	100	100	200	50.8
SHCM5060C508	○				150	100	250	50.8
SHCL5060C508	○				200	100	300	50.8
SHCE5060C508	○				250	100	350	50.8

本体にチップは組込んでありません。

### ■使用チップ

用途 Applicable	形番 Cat.No.	コーティング Coating		寸法 (mm) Dimensions (mm)					Fig.
		Coated		R	A	B	T	r	
		JCS025	JCS045						
一般加工用 For general purpose	SHB250MN	○	—	25	32.5	25.739	6.0	—	1
	SHB250SN	○	—	25	41.537	21.245	6.0	—	2
重切削用 For heavy duty cutting	SHB250HMN	—	○	25	32.5	25.739	6.0	—	1
	SHB250HSN	—	○	25	41.537	21.245	6.0	—	2
外周刃 Peripheral blade	SPMW120404	○	—	—	12.7	12.7	4.762	0.4	3

### ■部品

クランプネジ Clamp screw		レンチ Wrench	
主刃用・副刃用 For Main blade & Sub blade	外周刃 For peripheral blade	主刃用・副刃用 For Main blade & Sub blade	外周刃 For peripheral blade
HSW-614	HSW-501	A-30	A-27

## ホソイチッパー"S" SHC-S形

- ストレートシャンク形  
2枚刃、2コーナ形



### ■ 本体

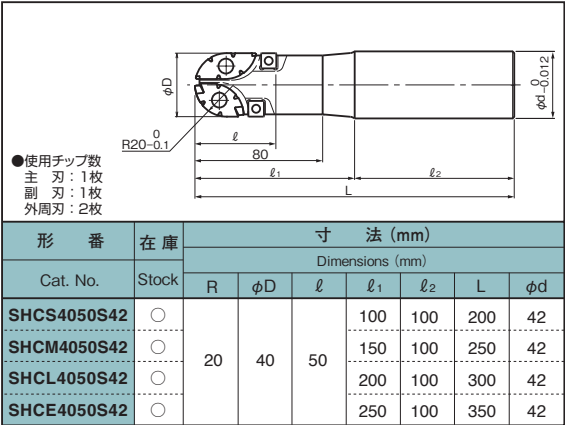

本体にチップは組込んでありません。

## ホソイチッパー"S" SHC-C形

- コンピネーションシャンク形  
2枚刃、2コーナ形



### ■ 本体

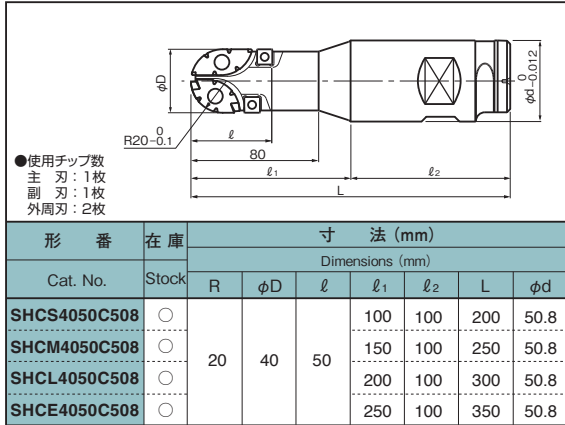

本体にチップは組込んでありません。

### ■ 使用チップ

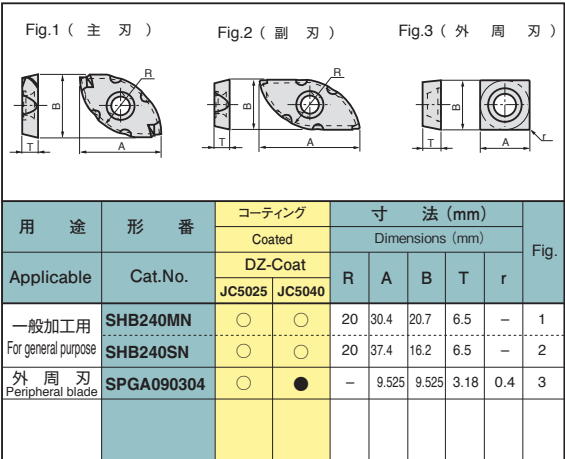

### ■ 使用チップ

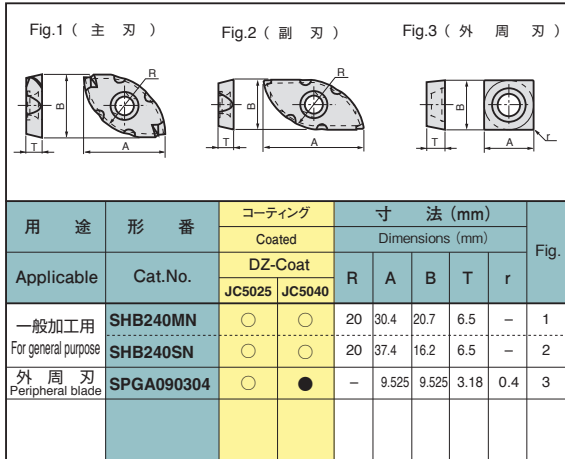

### ■ 部品

クランプネジ Clamp screw		レンチ Wrench	
主刃用・副刃用 For Main blade & Sub blade	外周刃 For peripheral blade	主刃用・副刃用 For Main blade & Sub blade	外周刃 For peripheral blade
TSW-612	ESW-406	A-25	A-15

### ■ 部品

クランプネジ Clamp screw		レンチ Wrench	
主刃用・副刃用 For Main blade & Sub blade	外周刃 For peripheral blade	主刃用・副刃用 For Main blade & Sub blade	外周刃 For peripheral blade
TSW-612	ESW-406	A-25	A-15

## ホソイチッパー"Ｓ" SHC-S形

- ストレートシャンク形  
2枚刃、2コーナ形



## ホソイチッパー"Ｓ" SHC-C形

- コンビネーションシャンク形  
2枚刃、2コーナ形



### ■本体

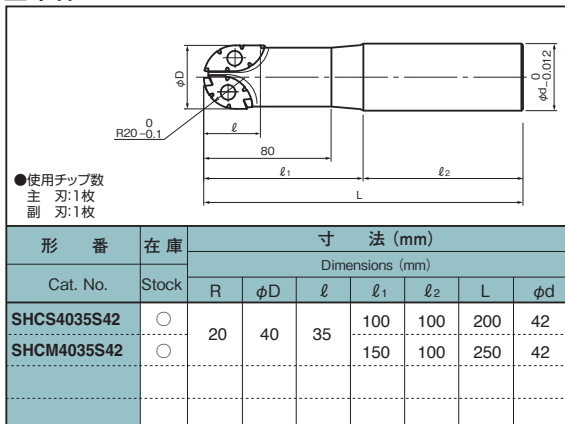

本体にチップは組込んでありません。

### ■本体

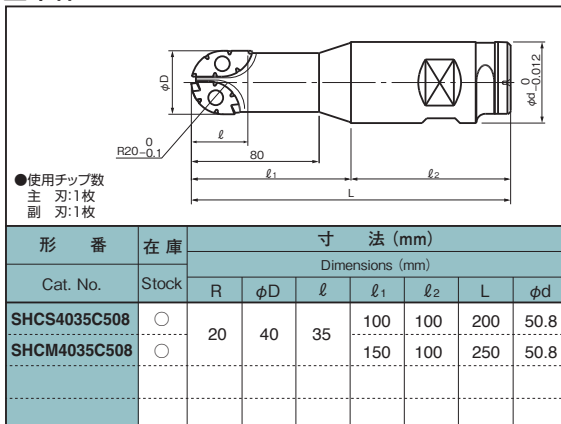

本体にチップは組込んでありません。

### ■使用チップ

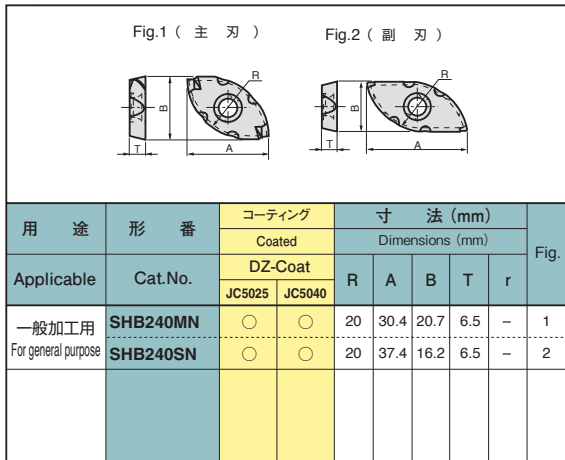

### ■使用チップ

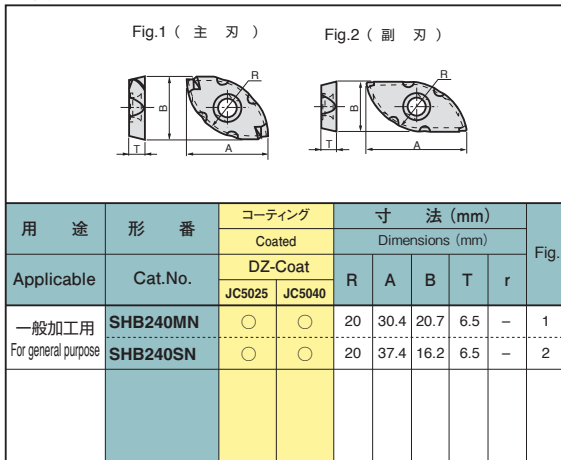

### ■部品

クランプネジ		レンチ	
Clamp screw		Wrench	
主刃用・副刃用	外周刃	主刃用・副刃用	外周刃
For Main blade & Sub blade	For peripheral blade	For Main blade & Sub blade	For peripheral blade
TSW-612	-	A-25	-

### ■部品

クランプネジ		レンチ	
Clamp screw		Wrench	
主刃用・副刃用	外周刃	主刃用・副刃用	外周刃
For Main blade & Sub blade	For peripheral blade	For Main blade & Sub blade	For peripheral blade
TSW-612	-	A-25	-

# ホソイチッパー"Ｓ" SHC-S形

- ストレートシャンク形  
2枚刃、2コーナ形



# ホソイチッパー"Ｓ" SHC-S形

- ストレートシャンク形  
2枚刃、2コーナ形



## ■本体

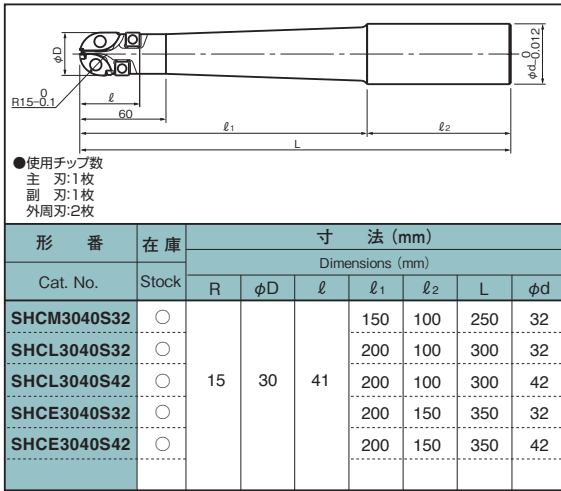

本体にチップは組込んでありません。

## ■本体

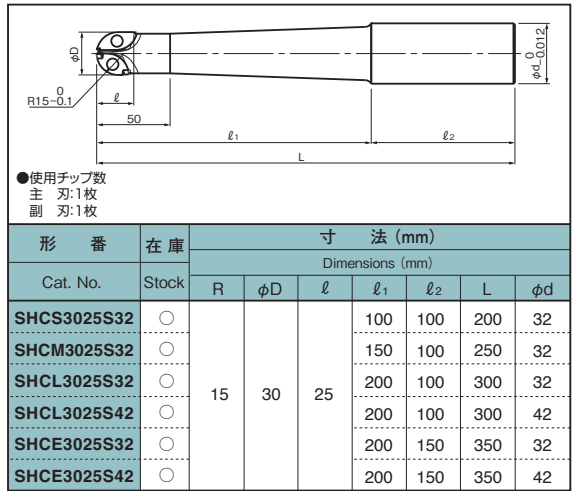

本体にチップは組込んでありません。

## ■使用チップ

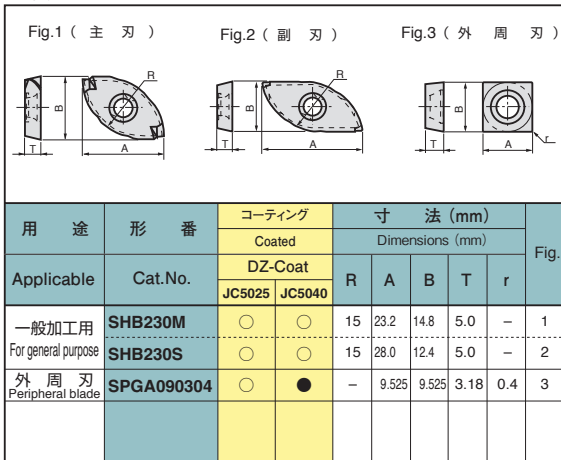

## ■使用チップ

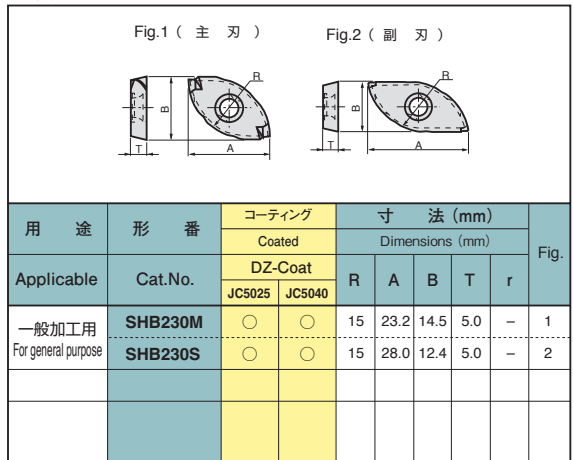

## ■部品

クランプネジ Clamp screw		レンチ Wrench	
主刃用・副刃用 For Main blade & Sub blade	外周刃 For peripheral blade	主刃用・副刃用 For Main blade & Sub blade	外周刃 For peripheral blade
DSW-509	ESW-406	A-20	A-15

## ■部品

クランプネジ Clamp screw		レンチ Wrench	
主刃用・副刃用 For Main blade & Sub blade	外周刃 For peripheral blade	主刃用・副刃用 For Main blade & Sub blade	外周刃 For peripheral blade
DSW-509		A-20	

# ホソイチッパー HCSS-1形

●1枚刃、1コーナ形



## ■本体

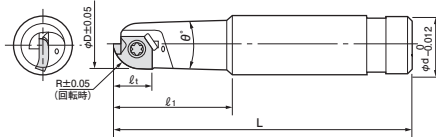

●使用チップ数:1枚

形番 Cat. No.	在庫 Stock	寸法 (mm) Dimensions (mm)						
		R	φD	ℓt	ℓ1	θ	L	φd
HCSS-112	<input type="checkbox"/>	6	12	10	30	16°	140	20
HCSS-116	<input type="checkbox"/>	8	16	13	40	10°	140	20
HCSS-120	<input type="checkbox"/>	10	20	15	60	8°	170	25
HCSS-125	<input type="checkbox"/>	12.5	25	19	70	10°	200	32
HCSS-130	<input type="checkbox"/>	15	30	23	80	3°	230	32

本体にチップは組込んでありません。

## ■使用チップ

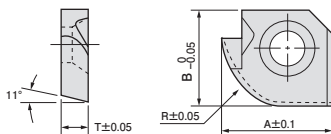

形番 Cat.No.	コーティング	サーメット	超硬合金		寸法 (mm)				適用ホルダ Applicable holder	
	Coated	Cermet	Uncoated	M	K	R	A	B		T
	JC3552	NAT		DX25	CR1					
HCB-112S	<input type="checkbox"/>	<input type="checkbox"/>	<input type="checkbox"/>	<input type="checkbox"/>	<input type="checkbox"/>	6	10.8	8.76	2.5	HCSS-112
HCB-116S	<input type="checkbox"/>	<input type="checkbox"/>	<input type="checkbox"/>	<input type="checkbox"/>	<input type="checkbox"/>	8	14.0	11.41	3.0	HCSS-116
HCB-120S	<input type="checkbox"/>	<input type="checkbox"/>	<input type="checkbox"/>	<input type="checkbox"/>	<input type="checkbox"/>	10	16.3	13.87	4.0	HCSS-120
HCB-125S	<input type="checkbox"/>	<input type="checkbox"/>	<input type="checkbox"/>	<input type="checkbox"/>	<input type="checkbox"/>	12.5	20.6	16.34	5.0	HCSS-125
HCB-130S	<input type="checkbox"/>	<input type="checkbox"/>	<input type="checkbox"/>	<input type="checkbox"/>	<input type="checkbox"/>	15	25.0	19.84	6.0	HCSS-130

注) NATはSC30に、DX25はUMSに順次置き換わる予定です。

## ■部品

クランプネジ Clamp screw	レンチ Wrench	適用ホルダ Applicable holder
HSW-306	A-10	HCSS-112
HSW-308	A-10	HCSS-116
HSW-409	A-25	HCSS-120
HSW-512	A-27	HCSS-125
HSW-614	A-30	HCSS-130

# ホソイチッパー HCLS-1形

ロングシャンク

●1枚刃、1コーナ形



## ■本体

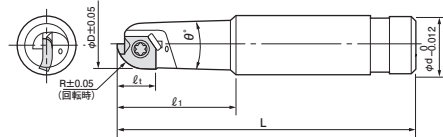

●使用チップ数:1枚

形番 Cat. No.	在庫 Stock	寸法 (mm) Dimensions (mm)						
		R	φD	ℓt	ℓ1	θ	L	φd
HCLS-112	<input type="checkbox"/>	6	12	10	30	16°	200	20
HCLS-116	<input type="checkbox"/>	8	16	13	40	10°	200	20
HCLS-125	<input type="checkbox"/>	12.5	25	19	70	10°	250	32
HCLS-130	<input type="checkbox"/>	15	30	23	80	3°	300	32
HCLS-132	<input type="checkbox"/>	16	32	24	80	-	300	32

本体にチップは組込んでありません。

## ■使用チップ

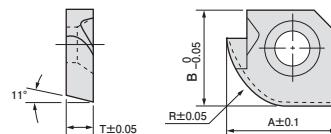

形番 Cat.No.	コーティング	サーメット	超硬合金		寸法 (mm)				適用ホルダ Applicable holder	
	Coated	Cermet	Uncoated	M	K	R	A	B		T
	JC3552	NAT		DX25	CR1					
HCB-112S	<input type="checkbox"/>	<input type="checkbox"/>	<input type="checkbox"/>	<input type="checkbox"/>	<input type="checkbox"/>	6	10.8	8.76	2.5	HCLS-112
HCB-116S	<input type="checkbox"/>	<input type="checkbox"/>	<input type="checkbox"/>	<input type="checkbox"/>	<input type="checkbox"/>	8	14.0	11.41	3.0	HCLS-116
HCB-120S	<input type="checkbox"/>	<input type="checkbox"/>	<input type="checkbox"/>	<input type="checkbox"/>	<input type="checkbox"/>	10	16.3	13.87	4.0	HCLS-120
HCB-125S	<input type="checkbox"/>	<input type="checkbox"/>	<input type="checkbox"/>	<input type="checkbox"/>	<input type="checkbox"/>	12.5	20.6	16.34	5.0	HCLS-125
HCB-130S	<input type="checkbox"/>	<input type="checkbox"/>	<input type="checkbox"/>	<input type="checkbox"/>	<input type="checkbox"/>	15	25.0	19.84	6.0	HCLS-130
HCB-132S	<input type="checkbox"/>	<input type="checkbox"/>	<input type="checkbox"/>	<input type="checkbox"/>	<input type="checkbox"/>	16	26.0	21.0	6.0	HCLS-132

注) NATはSC30に、DX25はUMSに順次置き換わる予定です。

## ■部品

クランプネジ Clamp screw	レンチ Wrench	適用ホルダ Applicable holder
HSW-306	A-10	HCLS-112
HSW-308	A-10	HCLS-116
HSW-409	A-25	HCLS-120
HSW-512	A-27	HCLS-125
HSW-614	A-30	HCLS-130, HCLS132

## ホソイチッパー HCSK-2形

- 2枚刃、2コーナ形  
チップ動き防止機構採用



### ■本体

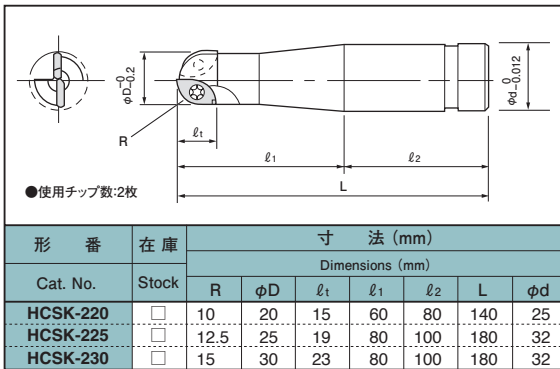

本体にチップは組込んでありません。

## ホソイチッパー HCLK-2形 ロング刃

- 2枚刃、2コーナ形  
チップ動き防止機構採用



### ■本体

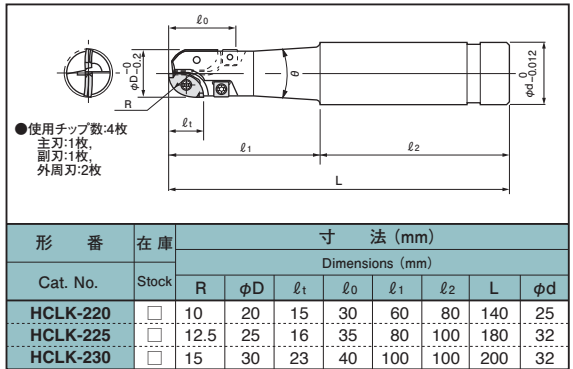

本体にチップは組込んでありません。

### ■使用チップ

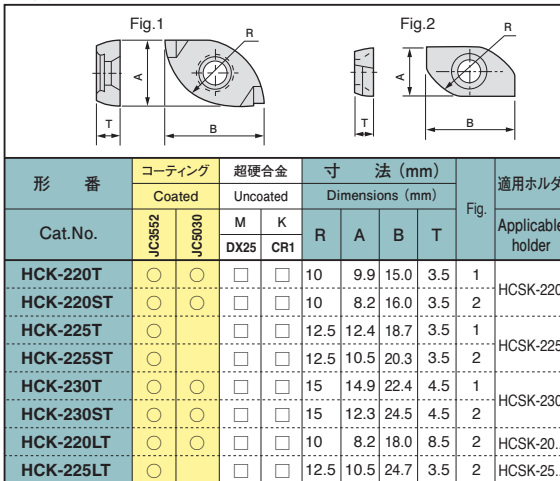

注) DX25はUMSIに順次置き換わる予定です。

### ■使用チップ

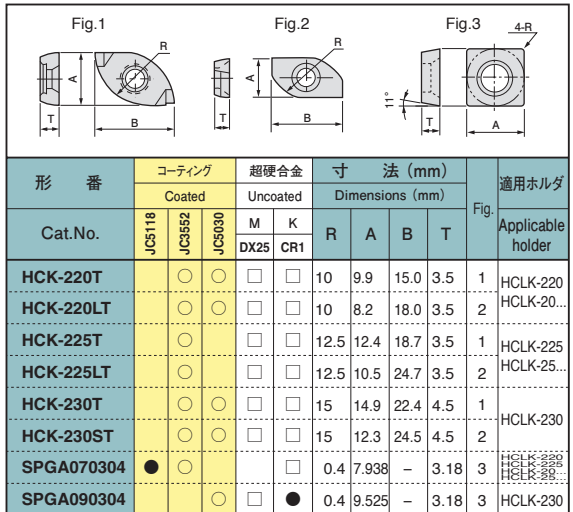

注) DX25はUMSIに順次置き換わる予定です。

### ■部品

クランプネジ Clamp screw	レンチ Wrench	適用ホルダ Applicable holder
DSW-307	A-10	HCSK-220
DSW-408	A-15	HCSK-225
DSW-509	A-20SD	HCSK-230

21

### ■部品

適用ホルダ Applicable holder	クランプネジ Clamp screw	レンチ Wrench
HCLK-220 主刃・副刃 For main & sub inserts 外周刃 For peripheral inserts	DSW-307 DSW-307	A-10 A-10
HCLK-225 主刃・副刃 For main & sub inserts 外周刃 For peripheral inserts	DSW-408 DSW-307	A-15 A-10
HCLK-230 主刃・副刃 For main & sub inserts 外周刃 For peripheral inserts	DSW-509 DSW-408	A-20SD A-15

21

## ホソイチッパー

## HCST-2形

●2枚刃、2コーナ形



### ■本体

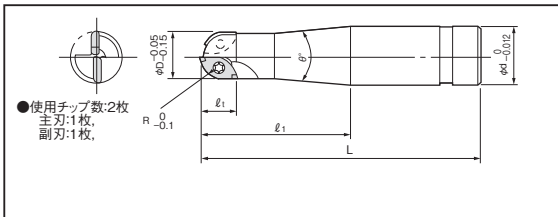

形番	在庫	寸法 (mm)						
		Dimensions (mm)						
Cat. No.	Stock	R	φD	ℓt	ℓ1	θ	L	φd
HCST-220	<input type="checkbox"/>	10	20	15	60	10°	140	25
HCST-225	<input type="checkbox"/>	12.5	25	19	70	12°	150	32
HCST-230	<input type="checkbox"/>	15	30	23	80	5°	160	32

本体にチップは組込んでありません。

### ■使用チップ

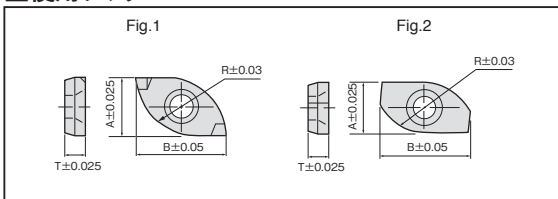

形番	コーティング		超硬合金	寸法 (mm)				適用ホルダ
	Coated			Dimensions (mm)				
	Cat.No.	JC3552	M DX25	R	A	B	T	
HCB-220T	<input type="checkbox"/>	<input type="checkbox"/>	10	9.7	15.0	3.5	1	HCST-220
HCB-220ST	<input type="checkbox"/>	<input type="checkbox"/>	10	8.5	14.0	3.5	2	
HCB-225T	<input type="checkbox"/>	<input type="checkbox"/>	12.5	12.2	19.0	3.5	1	HCST-225
HCB-225ST	<input type="checkbox"/>	<input type="checkbox"/>	12.5	11.0	17.7	3.5	2	
HCB-230T	<input type="checkbox"/>	<input type="checkbox"/>	15	14.6	23.0	4.5	1	HCST-230
HCB-230ST	<input type="checkbox"/>	<input type="checkbox"/>	15	12.6	21.1	4.5	2	

注) DX25はUMSに順次置き換わる予定です。

### ■部品

クランプネジ	レンチ	適用ホルダ
Clamp screw	Wrench	Applicable holder
DSW-307	A-10	HCST-220
HSW-401	A-25	HCST-225
HSW-501	A-27	HCST-230

## ホソイチッパー

## HCLT-2形 ロング刃

●2枚刃、2コーナ形



### ■本体

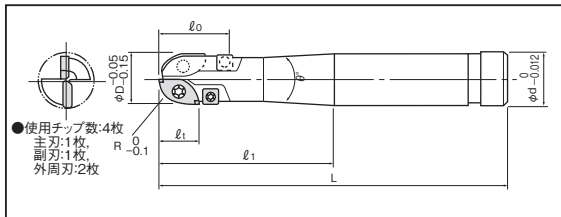

形番	在庫	寸法 (mm)							
		Dimensions (mm)							
Cat. No.	Stock	R	φD	ℓt	ℓ0	ℓ1	θ	L	φd
HCLT-220	<input type="checkbox"/>	10	20	15	30	50	30°	150	25
HCLT-225	<input type="checkbox"/>	12.5	25	19	35	80	13°	180	32
HCLT-230	<input type="checkbox"/>	15	30	23	40	100	3°	200	32

本体にチップは組込んでありません。

### ■使用チップ

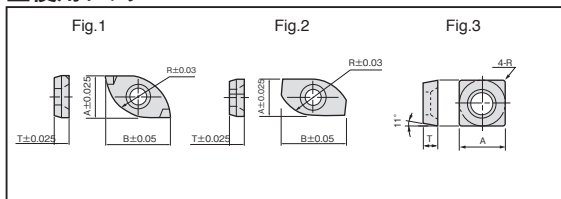

形番	コーティング			超硬合金	寸法 (mm)				適用ホルダ			
	Coated				Dimensions (mm)							
	Cat.No.	JC5118	JC3552	JC5040	M DX25	K CR1	R	A		B	T	Fig.
HCB-220T	<input type="checkbox"/>	<input type="checkbox"/>	<input type="checkbox"/>	<input type="checkbox"/>	<input type="checkbox"/>	<input type="checkbox"/>	10	9.7	15.0	3.5	1	HCLT-220
HCB-220LT	<input type="checkbox"/>	<input type="checkbox"/>	<input type="checkbox"/>	<input type="checkbox"/>	<input type="checkbox"/>	<input type="checkbox"/>	10	8.5	18.3	3.5	2	
HCB-225T	<input type="checkbox"/>	<input type="checkbox"/>	<input type="checkbox"/>	<input type="checkbox"/>	<input type="checkbox"/>	<input type="checkbox"/>	12.5	12.2	19.0	3.5	1	HCLT-225
HCB-225LT	<input type="checkbox"/>	<input type="checkbox"/>	<input type="checkbox"/>	<input type="checkbox"/>	<input type="checkbox"/>	<input type="checkbox"/>	12.5	11.0	23.0	3.5	2	
HCB-230T	<input type="checkbox"/>	<input type="checkbox"/>	<input type="checkbox"/>	<input type="checkbox"/>	<input type="checkbox"/>	<input type="checkbox"/>	15	14.6	23.0	4.5	1	HCLT-230
HCB-230LT	<input type="checkbox"/>	<input type="checkbox"/>	<input type="checkbox"/>	<input type="checkbox"/>	<input type="checkbox"/>	<input type="checkbox"/>	15	12.6	25.0	4.5	2	
SPGA070304	●	<input type="checkbox"/>	●	<input type="checkbox"/>	<input type="checkbox"/>	<input type="checkbox"/>	0.4	7.938	-	3.18	3	HCLT-220
SPGA070308	<input type="checkbox"/>	<input type="checkbox"/>	<input type="checkbox"/>	<input type="checkbox"/>	<input type="checkbox"/>	<input type="checkbox"/>	0.8	7.938	-	3.18	3	HCLT-225
SPGA090304	<input type="checkbox"/>	<input type="checkbox"/>	●	<input type="checkbox"/>	●	<input type="checkbox"/>	0.4	9.525	-	3.18	3	HCLT-230

注) DX25はUMSに順次置き換わる予定です。

### ■部品

適用ホルダ		クランプネジ	レンチ	
Applicable holder		Clamp screw	Wrench	
HCLT-220	主刃・副刃	For main & sub inserts	DSW-307	A-10
	外周刃	For peripheral inserts	DSW-307	A-10
HCLT-225	主刃・副刃	For main & sub inserts	HSW-401	A-25
	外周刃	For peripheral inserts	DSW-307	A-10
HCLT230	主刃・副刃	For main & sub inserts	HSW-501	A-27
	外周刃	For peripheral inserts	ESW-406	A-15



# ホソイチッパー

## HCLT-2形 ロング刃

●2枚刃、2コーナ形

# ホソイチッパー

## HCLT-1形 ロング刃

●2枚刃、1コーナ形



### ■本体

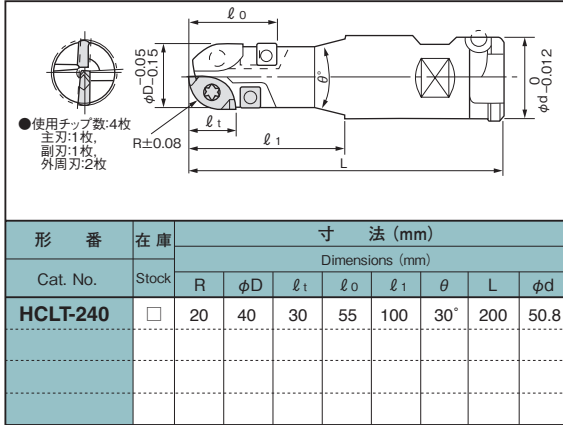

本体にチップは組込んでありません。

### ■本体

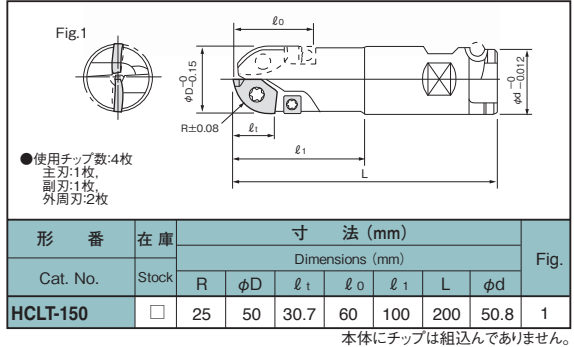

### ■使用チップ

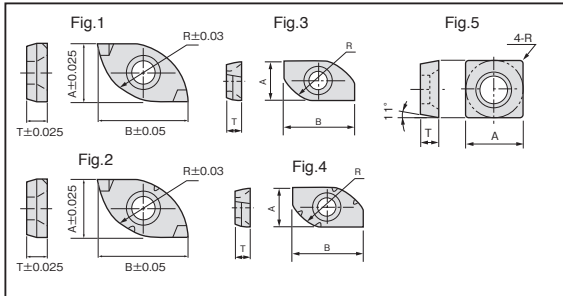

形番	コーティング		超硬合金		寸法 (mm)				適用ホルダ
	Coated	Uncoated	Uncoated		Dimensions (mm)				
Cat.No.	JC3552		M	K	R	A	B	T	Fig.
HCB-240T	○	<input type="checkbox"/>	<input type="checkbox"/>	<input type="checkbox"/>	20	19.7	30.0	6.0	1
HCB-240TN	○	<input type="checkbox"/>	<input type="checkbox"/>	<input type="checkbox"/>	20	19.7	30.0	6.0	2
HCB-240LT	○	<input type="checkbox"/>	<input type="checkbox"/>	<input type="checkbox"/>	20	16.7	32.3	6.0	3
HCB-240LTN	○	<input type="checkbox"/>	<input type="checkbox"/>	<input type="checkbox"/>	20	16.7	32.3	6.0	4
SPGA120404	○	<input type="checkbox"/>	<input type="checkbox"/>	<input type="checkbox"/>	0.4	12.70	-	4.76	5

注) DX25はUMSに順次置き換わる予定です。

### ■部品

適用	クランプネジ	レンチ
Applicable	Clamp screw	Wrench
主刃・副刃 For main & sub inserts	HSW-614	A-30
外周刃 For peripheral inserts	HSW-501	A-27

### ■使用チップ

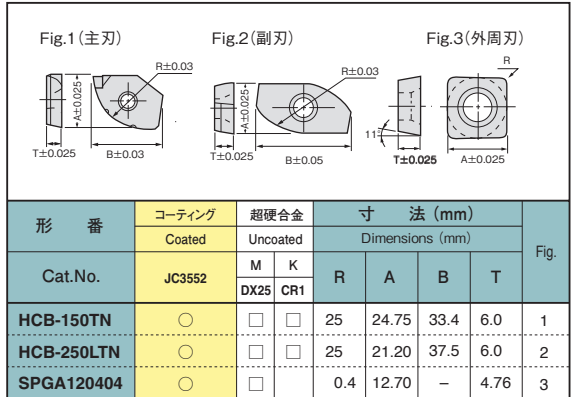

注) DX25はUMSに順次置き換わる予定です。

### ■部品

適用	クランプネジ	レンチ
Applicable	Clamp screw	Wrench
主刃・副刃 For main & sub inserts	HSW-614	A-30
外周刃 For peripheral inserts	HSW-501	A-27

## ホソイチッパー

## HCSS-1形 BTシャンク

- BTシャンク形  
1枚刃、1コーナ形



### ■本体

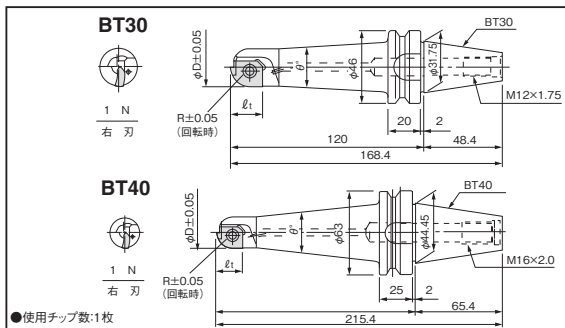

●使用チップ数:1枚

形番		在庫	寸法 (mm)				
Cat. No.			Stock	R	φD	ℓt	θ°
BT30	BT40	BT30					BT40
HCSS-112-BT30	HCSS-112-BT40	<input type="checkbox"/>	6	12	10	15°	18°
HCSS-116-BT30	HCSS-116-BT40	<input type="checkbox"/>	8	16	13	12°	16°
HCSS-120-BT30	HCSS-120-BT40	<input type="checkbox"/>	10	20	15	10°	15°
HCSS-125-BT30	HCSS-125-BT40	<input type="checkbox"/>	12.5	25	19	6°	12°
HCSS-130-BT30	HCSS-130-BT40	<input type="checkbox"/>	15	30	23	5°	10°
HCSS-132-BT30	HCSS-132-BT40	<input type="checkbox"/>	16	32	24	4°	16°

### ■使用チップ

本体にチップは組込んでありません。

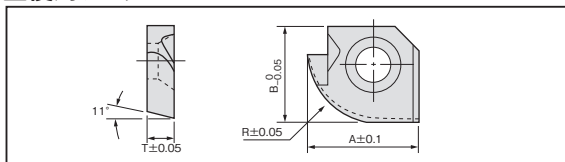

形番	コーティング		サメット		超硬合金		寸法 (mm)				適用ホルダ
	Coated	NAT	Cermet	Uncoated	M	K	R	A	B	T	
Cat.No.	JC3552				DX25	CR1					Applicable holder
HCB-112S	○	□	□	□	6	10.8	8.76	2.5	HCSS-112-BT30/BT40		
HCB-116S	○	□	□	□	8	14.0	11.41	3.0	HCSS-116-BT30/BT40		
HCB-120S	○	□	□	□	10	16.3	13.87	4.0	HCSS-120-BT30/BT40		
HCB-125S	○	□	□	□	12.5	20.6	16.34	5.0	HCSS-125-BT30/BT40		
HCB-130S	○	□	□	□	15	25.0	19.84	6.0	HCSS-130-BT30/BT40		
HCB-132S	○	□	□	□	16	26.0	21.0	6.0	HCSS-132-BT30/BT40		

注) NATはSC30に、DX25はUMSに順次置き換わる予定です。

### ■部品

クランプネジ	レンチ	適用ホルダ
Clamp screw	Wrench	Applicable holder
HSW-306	A-10	HCSS-112-BT30/BT40
HSW-308	A-10	HCSS-116-BT30/BT40
HSW-409	A-25	HCSS-120-BT30/BT40
HSW-512	A-27	HCSS-125-BT30/BT40
HSW-614	A-30	HCSS-130-BT30/BT40 HCSS-132-BT30/BT40

## ホソイチッパー

## HCSS-2形 BTシャンク

- BTシャンク形  
1枚刃、2コーナ形



### ■本体

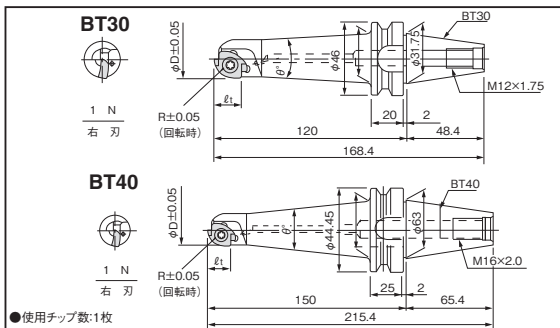

●使用チップ数:1枚

形番		在庫	寸法 (mm)				
Cat. No.			Stock	R	φD	ℓt	θ°
BT30	BT40	BT30					BT40
HCSS-216-BT30	HCSS-216-BT40	<input type="checkbox"/>	8	16	11.5	12°	16°
HCSS-220-BT30	HCSS-220-BT40	<input type="checkbox"/>	10	20	13	10°	15°
HCSS-225-BT30	HCSS-225-BT40	<input type="checkbox"/>	12.5	25	16.5	6°	12°
HCSS-230-BT30	HCSS-230-BT40	<input type="checkbox"/>	15	30	19	5°	10°

本体にチップは組込んでありません。

### ■使用チップ

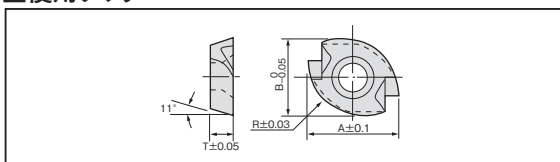

形番	コーティング		超硬合金		寸法 (mm)				適用ホルダ
	Coated	JC3552	Uncoated	M	R	A	B	T	
Cat.No.	JC3552			DX25					Applicable holder
HCB-216S	○	□	□	8	14	11.41	3.0	HCSS-216-BT30/BT40	
HCB-220S	○	□	□	10	16	13.87	4.0	HCSS-220-BT30/BT40	
HCB-225S	○	□	□	12.5	20	16.34	5.0	HCSS-250-BT30/BT40	
HCB-230S	○	□	□	15	23	19.84	6.0	HCSS-230-BT30/BT40	

注) DX25はUMSに順次置き換わる予定です。

### ■部品

クランプネジ	レンチ	適用ホルダ
Clamp screw	Wrench	Applicable holder
HSW-308	A-10	HCSS-216-BT30/BT40
HSW-409	A-25	HCSS-220-BT30/BT40
HSW-512	A-27	HCSS-225-BT30/BT40
HSW-614	A-30	HCSS-230-BT30/BT40

# ホソイチッパー

## HCST-2形 BTシャンク

- BTシャンク形  
2枚刃、2コーナ形



### ■本体

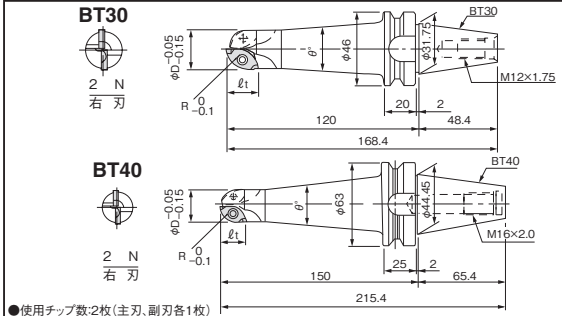

●使用チップ数:2枚(主刃、副刃各1枚)

形番		在庫		寸法 (mm)				
Cat. No.		Stock		Dimensions (mm)				
BT30	BT40			R	φD	ℓt	θ°	
							BT30	BT40
HCST-220-BT30	HCST-220-BT40	□	□	10	20	15	12°	15°
HCST-225-BT30	HCST-225-BT40	□	□	12.5	25	19	8°	12°
HCST-230-BT30	HCST-230-BT40	□	□	15	30	23	4°	10°

本体にチップは組込んでありません。

### ■使用チップ

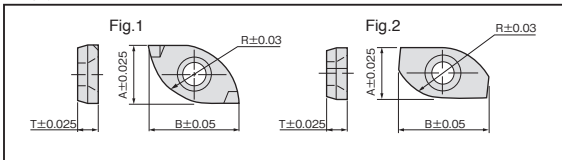

形番	コーティング		超硬合金	寸法 (mm)				Fig.	適用ホルダ
	Coated	Uncoated		Dimensions (mm)					
Cat.No.	JC3552	M DX25	R	A	B	T		Applicable holder	
HCST-220T	○	□	10	9.7	15.0	3.5	1	HCST-220-BT30/BT40	
HCST-220ST	○	□	10	8.5	14.0	3.5	2	HCST-220-BT30/BT40	
HCST-225T	○	□	12.5	12.2	19.0	3.5	1	HCLT-225-BT30/BT40	
HCST-225ST	○	□	12.5	11.0	17.7	3.5	2	HCLT-225-BT30/BT40	
HCST-230T	○	□	15	14.6	23.0	4.5	1	HCLT-230-BT30/BT40	
HCST-230ST	○	□	15	12.6	21.1	4.5	2	HCLT-230-BT30/BT40	

注) DX25はUMSに順次置き換わる予定です。

### ■部品

クランプネジ	レンチ	適用ホルダ
Clamp screw	Wrench	Applicable holder
DSW-307	A-10	HCST-220-BT30/BT40
HSW-401	A-25	HCST-225-BT30/BT40
HSW-501	A-27	HCST-230-BT30/BT40

31

# ホソイチッパー

## HCLT-2形 BTシャンク

- BTシャンク形  
2枚刃、2コーナ形、外周刃付



### ■本体

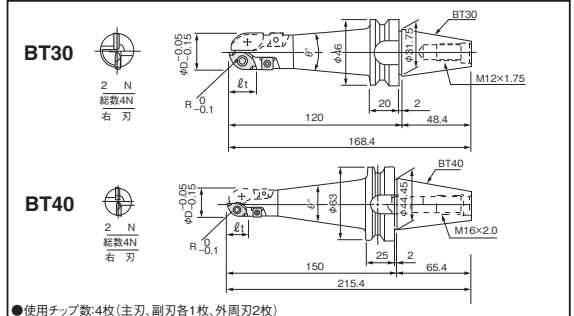

●使用チップ数:4枚(主刃、副刃各1枚、外周刃2枚)

形番		在庫		寸法 (mm)				
Cat. No.		Stock		Dimensions (mm)				
BT30	BT40			R	φD	ℓt	θ°	
							BT30	BT40
HCLT-220-BT30	HCLT-220-BT40	□	□	10	20	15	12°	15°
HCLT-225-BT30	HCLT-225-BT40	□	□	12.5	25	19	8°	12°
HCLT-230-BT30	HCLT-230-BT40	□	□	15	30	23	4°	10°

本体にチップは組込んでありません。

### ■使用チップ

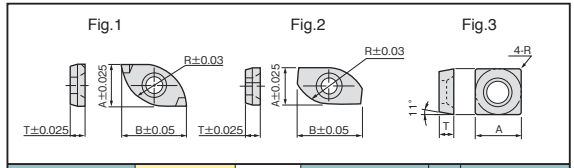

形番	コーティング			超硬合金	寸法 (mm)				Fig.	適用ホルダ	
	Coated	Uncoated	DX25		Dimensions (mm)						
Cat.No.	JC5118	JC3552	JC5940	M DX25	K CR1	R	A	B	T	Applicable holder	
HCB-220T	○	□	□	10	9.7	15.0	3.5	1	HCLT-220-BT30	HCLT-220-BT40	
HCB-220LT	○	□	□	10	8.5	18.3	3.5	2	HCLT-220-BT30	HCLT-220-BT40	
HCB-225T	○	□	□	12.5	12.2	19.0	3.5	1	HCLT-225-BT30	HCLT-225-BT40	
HCB-225LT	○	□	□	12.5	11.0	23.0	3.5	2	HCLT-225-BT30	HCLT-225-BT40	
HCB-230T	○	□	□	15	14.6	23.0	4.5	1	HCLT-230-BT30	HCLT-230-BT40	
HCB-230LT	○	□	□	15	12.6	25.0	4.5	2	HCLT-230-BT30	HCLT-230-BT40	
SPGA070304	●	○	●	□	0.4	7.938	-	3.18	3	HCLT-220-BT30	HCLT-220-BT40
SPGA070308	○	□	□	□	0.8	7.938	-	3.18	3	HCLT-225-BT30	HCLT-225-BT40
SPGA090304	○	□	●	□	0.4	9.525	-	3.18	3	HCLT-230-BT30	HCLT-230-BT40
SPGA090308	○	□	□	□	0.8	9.525	-	3.18	3	HCLT-230-BT30	HCLT-230-BT40

注) DX25はUMSに順次置き換わる予定です。

### ■部品

適用ホルダ		クランプネジ	レンチ
Applicable holder		Clamp screw	Wrench
HCLT-220	主刃・副刃	DSW-307	A-10
	外周刃	DSW-307	A-10
HCLT-225	主刃・副刃	HSW-401	A-25
	外周刃	DSW-307	A-10
HCLT-230	主刃・副刃	HSW-501	A-27
	外周刃	ESW-406	A-15

91

# エンドチッパー

# ECSPR-1形

- ストレートシャンク形  
1枚刃



## ■本体

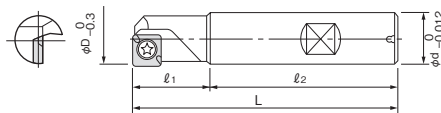

形番 Cat. No.	在庫 Stock	寸法 (mm) Dimensions (mm)				
		φD	l <sub>1</sub>	l <sub>2</sub>	L	φd
ECSPR-141S16	<input type="checkbox"/>	14	25	60	85	16
ECSPR-151S16	<input type="checkbox"/>	15	25	60	85	16
ECSPR-161S16	<input type="checkbox"/>	16	25	60	85	16
ECSPR-181S20	<input type="checkbox"/>	18	30	70	100	20
ECSPR-201S20	<input type="checkbox"/>	20	30	70	100	20
ECSPR-221S25	<input type="checkbox"/>	22	40	80	120	25

本体にチップは組込んでありません。

## ■使用チップ (エンドミリング専用)

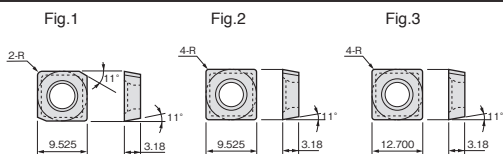

形番 Cat.No.	サメット Cemet			超硬合金 Uncoated		寸法 (mm) Dimensions (mm)		Fig.	適用ホルダ Applicable holder
	NAT	DX25	KT9	R					
SPMA090304-EW26	<input type="checkbox"/>	<input type="checkbox"/>	<input type="checkbox"/>	0.4	1			1	ECSPR-141S16
SPMA090308-EW26	<input type="checkbox"/>	<input type="checkbox"/>	<input type="checkbox"/>	0.8	1				
SPMA090304-EW27	<input type="checkbox"/>	<input type="checkbox"/>	<input type="checkbox"/>	0.4	1			1	ECSPR-151S16
SPMA090308-EW27	<input type="checkbox"/>	<input type="checkbox"/>	<input type="checkbox"/>	0.8	1				
SPMA090304	<input type="checkbox"/>	<input type="checkbox"/>	<input type="checkbox"/>	0.4	2			2	ECSPR-161S16 ECSPR-181S20
SPMA090308	<input type="checkbox"/>	<input type="checkbox"/>	<input type="checkbox"/>	0.8	2				
SPMA120304	<input type="checkbox"/>	<input type="checkbox"/>	<input type="checkbox"/>	0.4	3			3	ECSPR-201S20 ECSPR-221S25
SPMA120308	<input type="checkbox"/>	<input type="checkbox"/>	<input type="checkbox"/>	0.8	3				

注) NATはSC30に、DX25はUMSに順次置き換わる予定です。

## ■部品

適用 Applicable holder	クランプネジ Clamp screw	レンチ Wrench
ECSPR-141S16, 151S16	ESW-405	A-15
ECSPR-161S16, 181S20	ESW-406	A-15
ECSPR-201S20, 221S25	ESW-508	A-25

## ■使用チップ (エンドミリング及びドリリング加工用)

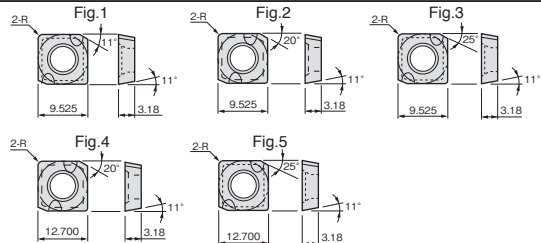

形番 Cat.No.	サメット Cemet			超硬合金 Uncoated		寸法 (mm) Dimensions (mm)		Fig.	適用ホルダ Applicable holder
	NAT	DX25	KT9	R					
SPMA090304-ET26	<input type="checkbox"/>	<input type="checkbox"/>	<input type="checkbox"/>	0.4	1			1	ECSPR-141S16
SPMA090308-ET26	<input type="checkbox"/>	<input type="checkbox"/>	<input type="checkbox"/>	0.8	1				
SPMA090304-ET27	<input type="checkbox"/>	<input type="checkbox"/>	<input type="checkbox"/>	0.4	1			1	ECSPR-151S16
SPMA090308-ET27	<input type="checkbox"/>	<input type="checkbox"/>	<input type="checkbox"/>	0.8	1				
SPMA090304-ET21	<input type="checkbox"/>	<input type="checkbox"/>	<input type="checkbox"/>	0.4	2			2	ECSPR-161S16 ECSPR-181S20
SPMA090308-ET21	<input type="checkbox"/>	<input type="checkbox"/>	<input type="checkbox"/>	0.8	2				
SPMA090304-ET25	<input type="checkbox"/>	<input type="checkbox"/>	<input type="checkbox"/>	0.4	3			3	ECSPR-201S20 ECSPR-221S25
SPMA090308-ET25	<input type="checkbox"/>	<input type="checkbox"/>	<input type="checkbox"/>	0.8	3				
SPMA120304-ET21	<input type="checkbox"/>	<input type="checkbox"/>	<input type="checkbox"/>	0.4	4			4	ECSPR-201S20
SPMA120308-ET21	<input type="checkbox"/>	<input type="checkbox"/>	<input type="checkbox"/>	0.8	4				
SPMA120304-ET24	<input type="checkbox"/>	<input type="checkbox"/>	<input type="checkbox"/>	0.4	5			5	ECSPR-221S25
SPMA120308-ET24	<input type="checkbox"/>	<input type="checkbox"/>	<input type="checkbox"/>	0.8	5				

注) NATはSC30に、DX25はUMSに順次置き換わる予定です。

## エンドチッパー ECZPR-1形

- ストレートシャンク形 1枚刃



### ■本体

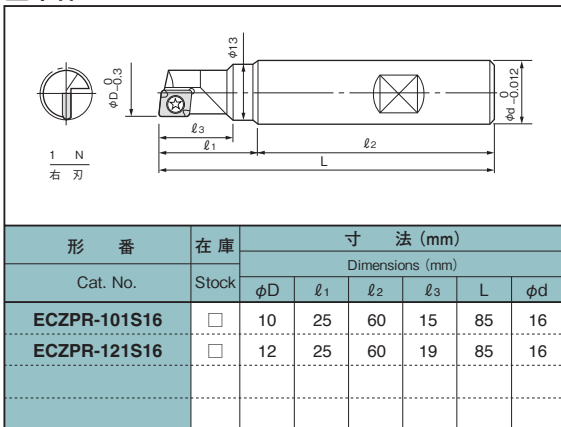

本体にチップは組込んでありません。

### ■使用チップ

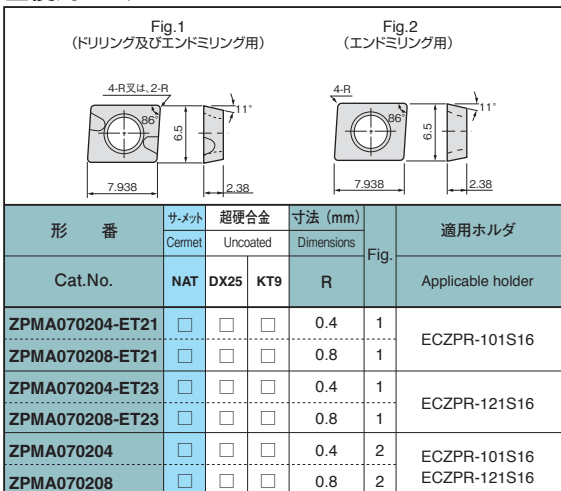

注) NATはSC30に、DX25はUMSに順次置き換わる予定です。

### ■部品

適用 Applicable holder	クランプネジ Clamp screw	レンチ Wrench
ECZPR-101S16	ESW-304	A-08
ECZPR-121S16		

## エンドチッパー ECSPR-2形

- ストレートシャンク形 2枚刃



### ■本体

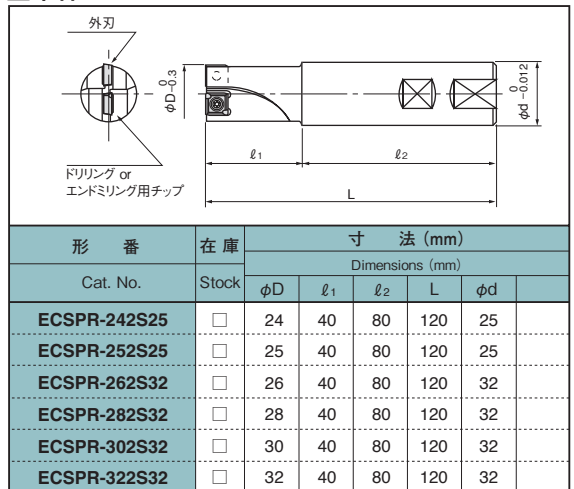

本体にチップは組込んでありません。

### ■使用チップ

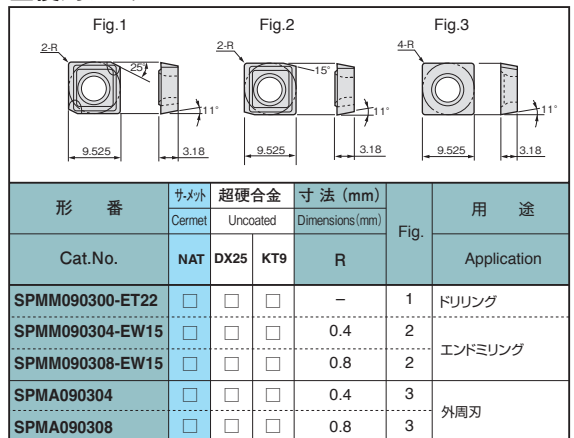

注) NATはSC30に、DX25はUMSに順次置き換わる予定です。

### ■部品

クランプネジ Clamp screw	レンチ Wrench
ESW-406	A-15

# エンドチッパー

# ECZPR-1-BT30 / BT40形

●BTシャンク形  
1枚刃



## ■本体

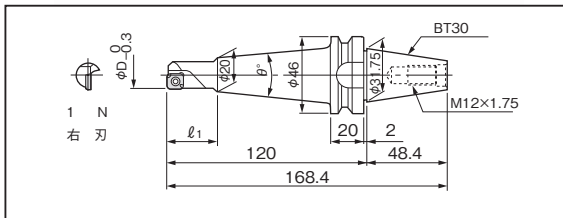

形番 Cat. No.	在庫 Stock	寸法 (mm) Dimensions (mm)		
		φD	ℓ <sub>1</sub>	θ
ECZPR-101-BT30	<input type="checkbox"/>	10	15	16°
ECZPR-111-BT30	<input type="checkbox"/>	11	15	16°
ECZPR-121-BT30	<input type="checkbox"/>	12	15	16°
ECZPR-131-BT30	<input type="checkbox"/>	13	15	16°

本体にチップは組込んでありません。

## ■本体

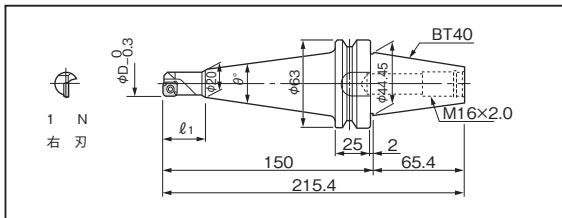

形番 Cat. No.	在庫 Stock	寸法 (mm) Dimensions (mm)		
		φD	ℓ <sub>1</sub>	θ
ECZPR-101-BT40	<input type="checkbox"/>	10	15	16°
ECZPR-111-BT40	<input type="checkbox"/>	11	15	16°
ECZPR-121-BT40	<input type="checkbox"/>	12	15	16°
ECZPR-131-BT40	<input type="checkbox"/>	13	15	16°

本体にチップは組込んでありません。

## ■使用チップ(エンドミリング及びドリリング用)

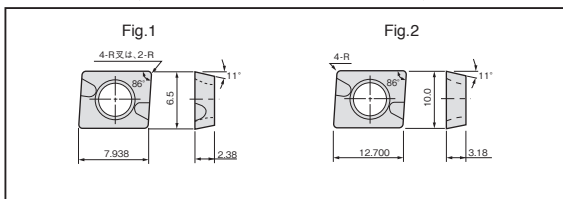

形番 Cat.No.	サメット Cermet		超硬合金 Uncoated		寸法 (mm) Dimensions		適用ホルダ Applicable holder
	NAT	DX25	KT9	R	Fig.		
ZPMA070204-ET21	<input type="checkbox"/>	<input type="checkbox"/>	<input type="checkbox"/>	0.4	1	ECZPR-101-BT30/BT40	
ZPMA070208-ET21	<input type="checkbox"/>	<input type="checkbox"/>	<input type="checkbox"/>	0.8	1		
ZPMA070204-ET22	<input type="checkbox"/>	<input type="checkbox"/>	<input type="checkbox"/>	0.4	1	ECZPR-111-BT30/BT40	
ZPMA070208-ET22	<input type="checkbox"/>	<input type="checkbox"/>	<input type="checkbox"/>	0.8	1		
ZPMA070204-ET23	<input type="checkbox"/>	<input type="checkbox"/>	<input type="checkbox"/>	0.4	1	ECZPR-121-BT30/BT40	
ZPMA070208-ET23	<input type="checkbox"/>	<input type="checkbox"/>	<input type="checkbox"/>	0.8	1		
ZPMA120304-ET21	<input type="checkbox"/>	<input type="checkbox"/>	<input type="checkbox"/>	0.4	2	ECZPR-131-BT30/BT40	
ZPMA120308-ET21	<input type="checkbox"/>	<input type="checkbox"/>	<input type="checkbox"/>	0.8	2		

注) NATはSC30に、DX25はUMSに順次置き換わる予定です。

81

## ■使用チップ(エンドミリング専用)

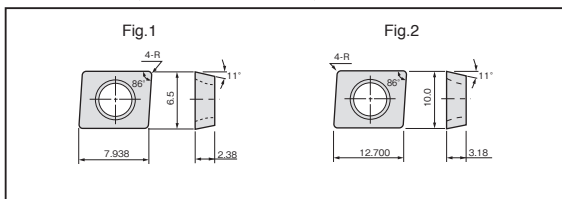

形番 Cat.No.	サメット Cermet		超硬合金 Uncoated		寸法 (mm) Dimensions		適用ホルダ Applicable holder
	NAT	DX25	KT9	R	Fig.		
ZPMA070204	<input type="checkbox"/>	<input type="checkbox"/>	<input type="checkbox"/>	0.4	1	ECZPR-101-BT30/BT40 ECZPR-111-BT30/BT40 ECZPR-121-BT30/BT40	
ZPMA070208	<input type="checkbox"/>	<input type="checkbox"/>	<input type="checkbox"/>	0.8	1		
ZPMA120304	<input type="checkbox"/>	<input type="checkbox"/>	<input type="checkbox"/>	0.4	2	ECZPR-131-BT30/BT40	
ZPMA120308	<input type="checkbox"/>	<input type="checkbox"/>	<input type="checkbox"/>	0.8	2		

注) NATはSC30に、DX25はUMSに順次置き換わる予定です。

## ■部品

適用ホルダ Applicable holder	クランプネジ Clamp screw	レンチ Wrench
ECZPR-101-BT30/BT40	ESW-304	A-08
ECZPR-111-BT30/BT40		
ECZPR-121-BT30/BT40		
ECZPR-131-BT30/BT40	ESW-405	A-15

31

# エンドチッパー

# ECSPR-1-BT30 / BT40形

●BTシャンク形  
1枚刃



## ■本体

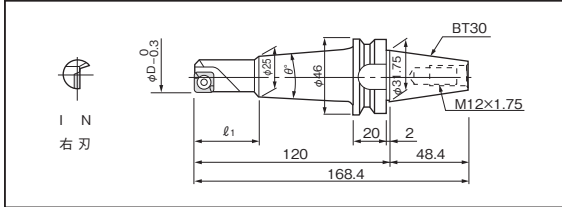

形番 Cat. No.	在庫 Stock	寸法 (mm) Dimensions (mm)		
		φD	ℓ <sub>1</sub>	θ
ECSPR-141-BT30	<input type="checkbox"/>	14	19	13°
ECSPR-151-BT30	<input type="checkbox"/>	15	19	13°
ECSPR-161-BT30	<input type="checkbox"/>	16	19	13°
ECSPR-171-BT30	<input type="checkbox"/>	17	19	11°
ECSPR-181-BT30	<input type="checkbox"/>	18	19	11°
ECSPR-191-BT30	<input type="checkbox"/>	19	19	11°
ECSPR-201-BT30	<input type="checkbox"/>	20	19	11°
ECSPR-211-BT30	<input type="checkbox"/>	21	19	8°
ECSPR-221-BT30	<input type="checkbox"/>	22	19	8°
ECSPR-231-BT30	<input type="checkbox"/>	23	19	8°

本体にチップは組込んでありません。

## ■本体

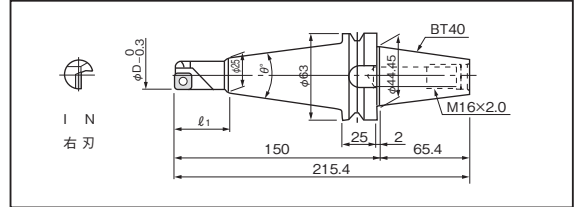

形番 Cat. No.	在庫 Stock	寸法 (mm) Dimensions (mm)		
		φD	ℓ <sub>1</sub>	θ
ECSPR-141-BT40	<input type="checkbox"/>	14	19	16°
ECSPR-151-BT40	<input type="checkbox"/>	15	19	16°
ECSPR-161-BT40	<input type="checkbox"/>	16	19	16°
ECSPR-171-BT40	<input type="checkbox"/>	17	19	16°
ECSPR-181-BT40	<input type="checkbox"/>	18	19	16°
ECSPR-191-BT40	<input type="checkbox"/>	19	19	16°
ECSPR-201-BT40	<input type="checkbox"/>	20	19	16°
ECSPR-211-BT40	<input type="checkbox"/>	21	19	16°
ECSPR-221-BT40	<input type="checkbox"/>	22	19	16°
ECSPR-231-BT40	<input type="checkbox"/>	23	19	16°

本体にチップは組込んでありません。

## ■使用チップ (エンドミリング専用)

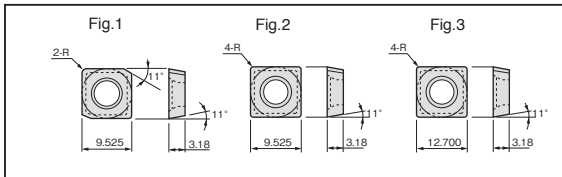

形番 Cat.No.	サメット Cemet		超硬合金 Uncoated		寸法 (mm) Dimensions (mm)		Fig.	適用ホルダ Applicable holder
	NAT	DX25	KT9	R				
SPMA090304-EW26	<input type="checkbox"/>	<input type="checkbox"/>	<input type="checkbox"/>	<input type="checkbox"/>	0.4	1	1	ECSPR-141-BT30/BT40
SPMA090308-EW26	<input type="checkbox"/>	<input type="checkbox"/>	<input type="checkbox"/>	<input type="checkbox"/>	0.8	1	1	ECSPR-151-BT30/BT40
SPMA090304-EW27	<input type="checkbox"/>	<input type="checkbox"/>	<input type="checkbox"/>	<input type="checkbox"/>	0.4	1	1	ECSPR-161-BT30/BT40 FCSPR-171-BT30/BT40
SPMA090308-EW27	<input type="checkbox"/>	<input type="checkbox"/>	<input type="checkbox"/>	<input type="checkbox"/>	0.8	1	1	ECSPR-181-BT30/BT40
SPMA090304	<input type="checkbox"/>	<input type="checkbox"/>	<input type="checkbox"/>	<input type="checkbox"/>	0.4	2	2	ECSPR-201-BT30/BT40 ECSPR-211-BT30/BT40
SPMA090308	<input type="checkbox"/>	<input type="checkbox"/>	<input type="checkbox"/>	<input type="checkbox"/>	0.8	2	2	ECSPR-221-BT30/BT40 ECSPR-231-BT30/BT40
SPMA120304	<input type="checkbox"/>	<input type="checkbox"/>	<input type="checkbox"/>	<input type="checkbox"/>	0.4	3	3	
SPMA120308	<input type="checkbox"/>	<input type="checkbox"/>	<input type="checkbox"/>	<input type="checkbox"/>	0.8	3	3	

注) NATはSC30に、DX25はUMSに順次置き換わる予定です。

## ■部品

適用 Applicable holder	クランプネジ Clamp screw	レンチ Wrench
ECSPR-141,151	ESW-405	A-15
ECSPR-161,171,181	ESW-406	A-15
ECSPR-191	ESW-507	A-25
ECSPR-201,211,221,231	ESW-508	A-25

61

## ■使用チップ (エンドミリング及びドリリング加工用)

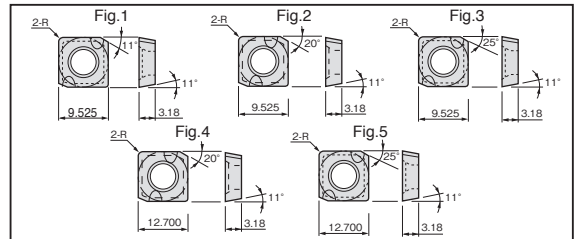

形番 Cat.No.	サメット Cemet		超硬合金 Uncoated		寸法 (mm) Dimensions (mm)		Fig.	適用ホルダ Applicable holder
	NAT	DX25	KT9	R				
SPMA090304-ET26	<input type="checkbox"/>	<input type="checkbox"/>	<input type="checkbox"/>	<input type="checkbox"/>	0.4	1	1	ECSPR-141-BT30/BT40
SPMA090308-ET26	<input type="checkbox"/>	<input type="checkbox"/>	<input type="checkbox"/>	<input type="checkbox"/>	0.8	1	1	ECSPR-151-BT30/BT40
SPMA090304-ET27	<input type="checkbox"/>	<input type="checkbox"/>	<input type="checkbox"/>	<input type="checkbox"/>	0.4	1	1	ECSPR-161-SBT30/BT40
SPMA090308-ET27	<input type="checkbox"/>	<input type="checkbox"/>	<input type="checkbox"/>	<input type="checkbox"/>	0.8	1	1	ECSPR-171-BT30/BT40
SPMA090304-ET21	<input type="checkbox"/>	<input type="checkbox"/>	<input type="checkbox"/>	<input type="checkbox"/>	0.4	2	2	ECSPR-181-BT30/BT40
SPMA090308-ET21	<input type="checkbox"/>	<input type="checkbox"/>	<input type="checkbox"/>	<input type="checkbox"/>	0.8	2	2	ECSPR-191-BT30/BT40
SPMA090304-ET24	<input type="checkbox"/>	<input type="checkbox"/>	<input type="checkbox"/>	<input type="checkbox"/>	0.4	3	3	ECSPR-201-BT30/BT40
SPMA090308-ET24	<input type="checkbox"/>	<input type="checkbox"/>	<input type="checkbox"/>	<input type="checkbox"/>	0.8	3	3	ECSPR-211-BT30/BT40
SPMA090304-ET25	<input type="checkbox"/>	<input type="checkbox"/>	<input type="checkbox"/>	<input type="checkbox"/>	0.4	3	3	ECSPR-221-BT30/BT40
SPMA090308-ET25	<input type="checkbox"/>	<input type="checkbox"/>	<input type="checkbox"/>	<input type="checkbox"/>	0.8	3	3	ECSPR-231-BT30/BT40
SPMA120304-ET22	<input type="checkbox"/>	<input type="checkbox"/>	<input type="checkbox"/>	<input type="checkbox"/>	0.4	5	5	
SPMA120308-ET22	<input type="checkbox"/>	<input type="checkbox"/>	<input type="checkbox"/>	<input type="checkbox"/>	0.8	5	5	
SPMA120304-ET21	<input type="checkbox"/>	<input type="checkbox"/>	<input type="checkbox"/>	<input type="checkbox"/>	0.4	4	4	ECSPR-201-BT30/BT40
SPMA120308-ET21	<input type="checkbox"/>	<input type="checkbox"/>	<input type="checkbox"/>	<input type="checkbox"/>	0.8	4	4	ECSPR-211-BT30/BT40
SPMA120304-ET23	<input type="checkbox"/>	<input type="checkbox"/>	<input type="checkbox"/>	<input type="checkbox"/>	0.4	5	5	ECSPR-221-BT30/BT40
SPMA120308-ET23	<input type="checkbox"/>	<input type="checkbox"/>	<input type="checkbox"/>	<input type="checkbox"/>	0.8	5	5	ECSPR-231-BT30/BT40
SPMA120304-ET24	<input type="checkbox"/>	<input type="checkbox"/>	<input type="checkbox"/>	<input type="checkbox"/>	0.4	5	5	ECSPR-221-BT30/BT40
SPMA120308-ET24	<input type="checkbox"/>	<input type="checkbox"/>	<input type="checkbox"/>	<input type="checkbox"/>	0.8	5	5	ECSPR-231-BT30/BT40
SPMA120304-ET25	<input type="checkbox"/>	<input type="checkbox"/>	<input type="checkbox"/>	<input type="checkbox"/>	0.4	5	5	ECSPR-231-BT30/BT40
SPMA120308-ET25	<input type="checkbox"/>	<input type="checkbox"/>	<input type="checkbox"/>	<input type="checkbox"/>	0.8	5	5	ECSPR-231-BT30/BT40

注) NATはSC30に、DX25はUMSに順次置き換わる予定です。

21



# エンドチッパー

# ECSPR-2-BT30 / BT40形

- BTシャンク形  
2枚刃



## ■本体

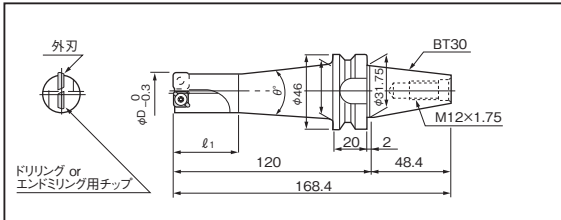

形番 Cat. No.	在庫 Stock	寸法 (mm) Dimensions (mm)		
		φD	ℓ <sub>1</sub>	θ
ECSPR-242-BT30	<input type="checkbox"/>	24	40	11°
ECSPR-252-BT30	<input type="checkbox"/>	25	40	10°
ECSPR-262-BT30	<input type="checkbox"/>	26	40	9°
ECSPR-272-BT30	<input type="checkbox"/>	27	40	8°
ECSPR-282-BT30	<input type="checkbox"/>	28	40	7°
ECSPR-292-BT30	<input type="checkbox"/>	29	40	6°
ECSPR-302-BT30	<input type="checkbox"/>	30	40	5°
ECSPR-312-BT30	<input type="checkbox"/>	31	40	4°
ECSPR-322-BT30	<input type="checkbox"/>	32	40	3°

本体にチップは組込んでありません。

## ■本体

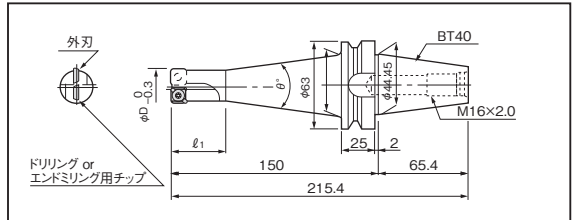

形番 Cat. No.	在庫 Stock	寸法 (mm) Dimensions (mm)		
		φD	ℓ <sub>1</sub>	θ
ECSPR-242-BT40	<input type="checkbox"/>	24	40	16°
ECSPR-252-BT40	<input type="checkbox"/>	25	40	15°
ECSPR-262-BT40	<input type="checkbox"/>	26	40	14°
ECSPR-272-BT40	<input type="checkbox"/>	27	40	14°
ECSPR-282-BT40	<input type="checkbox"/>	28	40	13°
ECSPR-292-BT40	<input type="checkbox"/>	29	40	12°
ECSPR-302-BT40	<input type="checkbox"/>	30	40	12°
ECSPR-312-BT40	<input type="checkbox"/>	31	40	11°
ECSPR-322-BT40	<input type="checkbox"/>	32	40	10°

本体にチップは組込んでありません。

## ■使用チップ

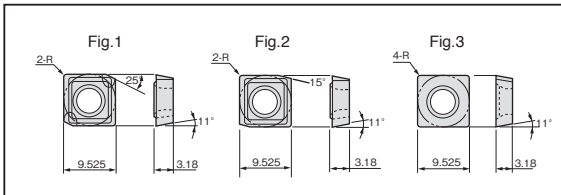

形番 Cat.No.	サメット Cermet		超硬合金 Uncoated		寸法 (mm) Dimensions (mm)		Fig.	用途 Application
	NAT	DX25	KT9	R				
SPMM090300-ET22	<input type="checkbox"/>	<input type="checkbox"/>	<input type="checkbox"/>	-	1	エンドミリング		
SPMM090304-EW15	<input type="checkbox"/>	<input type="checkbox"/>	<input type="checkbox"/>	0.4	2	エンドミリング、 及びドリリング		
SPMM090308-EW15	<input type="checkbox"/>	<input type="checkbox"/>	<input type="checkbox"/>	0.8	2			
SPMA090304	<input type="checkbox"/>	<input type="checkbox"/>	<input type="checkbox"/>	0.4	3	エンドミリング		
SPMA090308	<input type="checkbox"/>	<input type="checkbox"/>	<input type="checkbox"/>	0.8	3			

注) NATはSC30に、DX25はUMSに順次置き換わる予定です。

## ■使用チップ

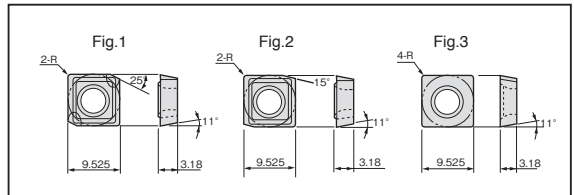

形番 Cat.No.	サメット Cermet		超硬合金 Uncoated		寸法 (mm) Dimensions (mm)		Fig.	用途 Application
	NAT	DX25	KT9	R				
SPMM090300-ET22	<input type="checkbox"/>	<input type="checkbox"/>	<input type="checkbox"/>	-	1	エンドミリング		
SPMM090304-EW15	<input type="checkbox"/>	<input type="checkbox"/>	<input type="checkbox"/>	0.4	2	エンドミリング、 及びドリリング		
SPMM090308-EW15	<input type="checkbox"/>	<input type="checkbox"/>	<input type="checkbox"/>	0.8	2			
SPMA090304	<input type="checkbox"/>	<input type="checkbox"/>	<input type="checkbox"/>	0.4	3	エンドミリング		
SPMA090308	<input type="checkbox"/>	<input type="checkbox"/>	<input type="checkbox"/>	0.8	3			

注) NATはSC30に、DX25はUMSに順次置き換わる予定です。

## ■部品

クランプネジ Clamp screw	レンチ Wrench
ESW-406	A-15

## ■部品

クランプネジ Clamp screw	レンチ Wrench
ESW-406	A-15



# エンドチッパー

# SL-ECSPR-1形 / XL-ECSPR-1形

- ストレートシャンク形  
1枚刃



## ■本体

形番	在庫	寸法 (mm)				
		φD	l <sub>1</sub>	l <sub>2</sub>	L	φd
SL-ECSPR-161S20	<input type="checkbox"/>	16	25	115	140	20
SL-ECSPR-181S20	<input type="checkbox"/>	18	25	115	140	20
SL-ECSPR-191S20	<input type="checkbox"/>	19	25	115	140	20
SL-ECSPR-201S25	<input type="checkbox"/>	20	30	140	170	25
SL-ECSPR-211S25	<input type="checkbox"/>	21	30	140	170	25
SL-ECSPR-221S25	<input type="checkbox"/>	22	30	140	170	25

本体にチップは組込んでありません。

## ■本体

形番	在庫	寸法 (mm)					
		φD	l <sub>1</sub>	l <sub>2</sub>	l <sub>3</sub>	L	φd
XL-ECSPR-161S25	<input type="checkbox"/>	16	100	100	48	200	25
XL-ECSPR-181S32	<input type="checkbox"/>	18	125	125	54	250	32
XL-ECSPR-201S32	<input type="checkbox"/>	20	125	125	60	250	32
XL-ECSPR-221S32	<input type="checkbox"/>	22	125	125	66	250	32

本体にチップは組込んでありません。

## ■使用チップ (エンドミリング専用)

形番	サメット		超硬合金		寸法 (mm)		Fig.	適用ホルダ
	Cermet	Uncoated	DX25	KT9	Dimensions (mm)			
SPMA090304	<input type="checkbox"/>	<input type="checkbox"/>	<input type="checkbox"/>	<input type="checkbox"/>	0.4	1	1	SL/XL-ECSPR-161 SL/XL-ECSPR-181
SPMA090308	<input type="checkbox"/>	<input type="checkbox"/>	<input type="checkbox"/>	<input type="checkbox"/>	0.8	1	1	SL-ECSPR-191 SL/XL-ECSPR-201 SL-ECSPR-211 SL/XL-ECSPR-221
SPMA120304	<input type="checkbox"/>	<input type="checkbox"/>	<input type="checkbox"/>	<input type="checkbox"/>	0.4	2	2	
SPMA120308	<input type="checkbox"/>	<input type="checkbox"/>	<input type="checkbox"/>	<input type="checkbox"/>	0.8	2	2	

注) NATはSC30に、DX25はUMSに順次置き換わる予定です。

## ■部品

適用ホルダ	クランプネジ	レンチ
Applicable holder	Clamp screw	Wrench
ECSPR-161,171,181	ESW-406	A-15
ECSPR-191	ESW-507	A-25
ECSPR-201,211,221,231	ESW-508	A-25

41

## ■使用チップ (エンドミリング及びドリリング加工用)

形番	サメット		超硬合金		寸法 (mm)		Fig.	適用ホルダ
	Cermet	Uncoated	DX25	KT9	Dimensions (mm)			
SPMA090304-ET21	<input type="checkbox"/>	<input type="checkbox"/>	<input type="checkbox"/>	<input type="checkbox"/>	0.4	1	1	SL/XL-ECSPR-161
SPMA090308-ET21	<input type="checkbox"/>	<input type="checkbox"/>	<input type="checkbox"/>	<input type="checkbox"/>	0.8	1	1	SL/XL-ECSPR-161
SPMA090304-ET25	<input type="checkbox"/>	<input type="checkbox"/>	<input type="checkbox"/>	<input type="checkbox"/>	0.4	2	2	SL/XL-ECSPR-181
SPMA090308-ET25	<input type="checkbox"/>	<input type="checkbox"/>	<input type="checkbox"/>	<input type="checkbox"/>	0.8	2	2	SL/XL-ECSPR-181
SPMA120304-ET22	<input type="checkbox"/>	<input type="checkbox"/>	<input type="checkbox"/>	<input type="checkbox"/>	0.4	4	4	SL-ECSPR-191
SPMA120308-ET22	<input type="checkbox"/>	<input type="checkbox"/>	<input type="checkbox"/>	<input type="checkbox"/>	0.8	4	4	SL-ECSPR-191
SPMA120304-ET21	<input type="checkbox"/>	<input type="checkbox"/>	<input type="checkbox"/>	<input type="checkbox"/>	0.4	3	3	SL/XL-ECSPR-201
SPMA120308-ET21	<input type="checkbox"/>	<input type="checkbox"/>	<input type="checkbox"/>	<input type="checkbox"/>	0.8	3	3	SL/XL-ECSPR-201
SPMA120304-ET23	<input type="checkbox"/>	<input type="checkbox"/>	<input type="checkbox"/>	<input type="checkbox"/>	0.4	4	4	SL-ECSPR-211
SPMA120308-ET23	<input type="checkbox"/>	<input type="checkbox"/>	<input type="checkbox"/>	<input type="checkbox"/>	0.8	4	4	SL-ECSPR-211
SPMA120304-ET24	<input type="checkbox"/>	<input type="checkbox"/>	<input type="checkbox"/>	<input type="checkbox"/>	0.4	4	4	SL/XL-ECSPR-221
SPMA120308-ET24	<input type="checkbox"/>	<input type="checkbox"/>	<input type="checkbox"/>	<input type="checkbox"/>	0.8	4	4	SL/XL-ECSPR-221

注) NATはSC30に、DX25はUMSに順次置き換わる予定です。

31

## エンドチッパー SL-ECSPR-2形

- ストレートシャンク形  
2枚刃



### ■本体

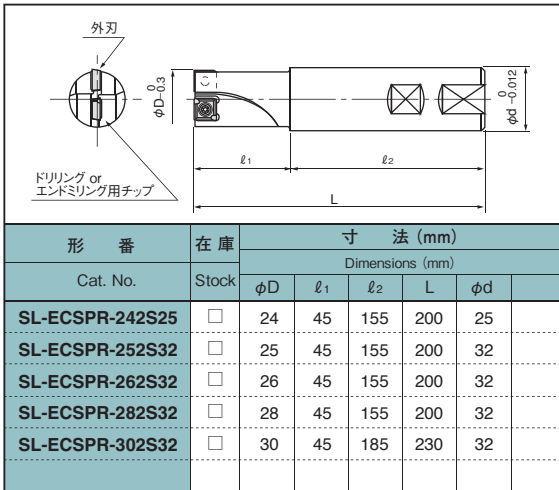

本体にチップは組込んでありません。

### ■使用チップ

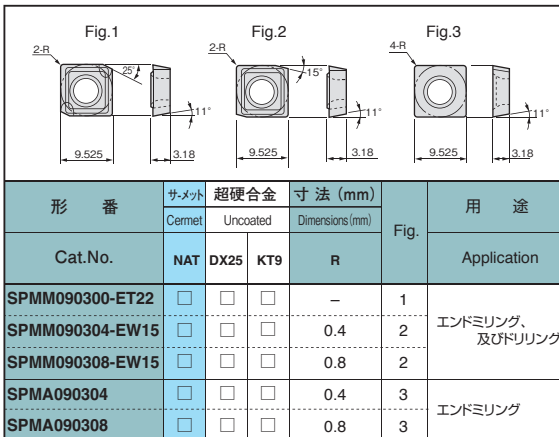

注) NATはSC30に、DX25はUMSに順次置き換わる予定です。

### ■部品

クランプネジ Clamp screw	レンチ Wrench
ESW-406	A-15

## エンドチッパー XL-ECSPR-2形

- ストレートシャンク形  
2枚刃



### ■本体

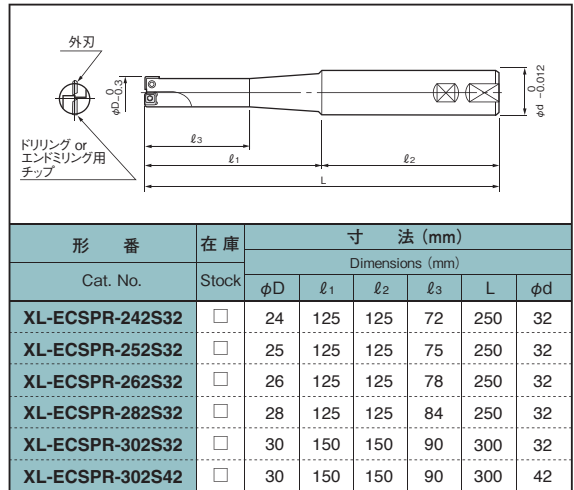

本体にチップは組込んでありません。

### ■使用チップ

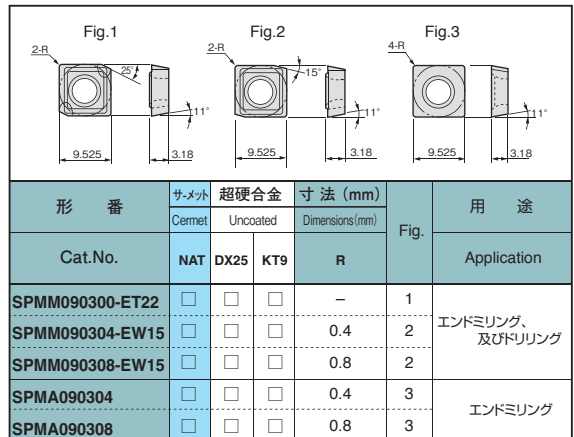

注) NATはSC30に、DX25はUMSに順次置き換わる予定です。

### ■部品

クランプネジ Clamp screw	レンチ Wrench
ESW-406	A-15

肩削り加工用

# スウィングミル・ミニ

# DSM-M形

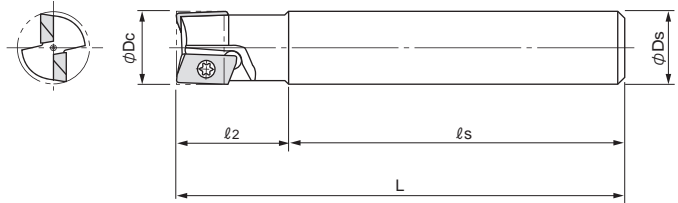

## ■本体

形番	在庫	刃数	寸法 (mm)					対応チップ	部品	
			φDc	l2	ls	L	φDs		クランプねじ	レンチ
DSM-1100M-S10	●	1	10	20	60	80	10	APGT0902GDR		
DSM-1120M-S12	●	1	12	25	55	80	12	APGT0902GDR		
DSM-1140M-S16	●	1	14	25	75	100	16	APGT1202GDR		
DSM-2160M-S16	●	2	16	25	75	100	16	APGT1202GDR	CSW-206	A-08
DSM-2200M-S20	●	2	20	30	90	120	20	APGT1202GDR		
DSM-3200M-S20	●	3	20	30	90	120	20	APGT1202GDR		
DSM-3250M-S25	●	3	25	30	90	120	25	APGT1202GDR		
DSM-4300M-S32	●	4	30	30	100	130	32	APGT1202GDR		

注) 本体にチップは組込んでありません。

## ■対応チップ

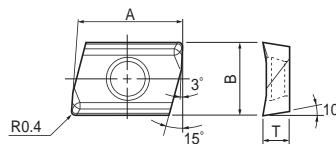

形番	PVD コーティング			CVD コーティング	超硬合金	寸法 (mm)		
	JC5118	JC5030	JC5040	JC610		A	B	T
APGT0902GDR	●	○	●	□		9.525	6.35	2.38
APGT1202GDR	●	○	●	●	●	12.700	6.35	2.38

1ケース10個入りです。

91

## Rチップー RCPR-1-BT30形

●BT-30シャンク形  
1枚刃



## Rチップー RCPR-1-BT40形

●BT-40シャンク形  
1枚刃



### ■本体

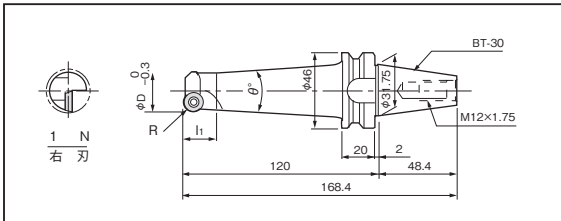

形番 Cat. No.	在庫 Stock	寸法 (mm) Dimensions (mm)		
		$\phi D$	R	$l_1$
RCPR-121-08-BT30	<input type="checkbox"/>	12	4	16
RCPR-161-08-BT30	<input type="checkbox"/>	16	4	16
RCPR-201-10-BT30	<input type="checkbox"/>	20	5	16
RCPR-251-12-BT30	<input type="checkbox"/>	25	6	20
RCPR-301-16-BT30	<input type="checkbox"/>	30	8	24
RCPR-321-16-BT30	<input type="checkbox"/>	32	8	24

本体にチップは組込んでありません。

### ■本体

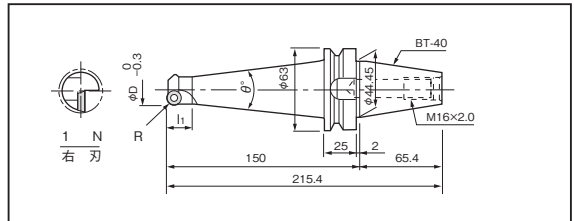

形番 Cat. No.	在庫 Stock	寸法 (mm) Dimensions (mm)		
		$\phi D$	R	$l_1$
RCPR-121-08-BT40	<input type="checkbox"/>	12	4	16
RCPR-161-08-BT40	<input type="checkbox"/>	16	4	16
RCPR-201-10-BT40	<input type="checkbox"/>	20	5	16
RCPR-251-12-BT40	<input type="checkbox"/>	25	6	20
RCPR-301-16-BT40	<input type="checkbox"/>	30	8	24
RCPR-321-16-BT40	<input type="checkbox"/>	32	8	24

本体にチップは組込んでありません。

### ■使用チップ

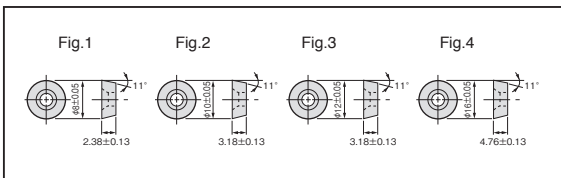

形番 Cat.No.	コーティング Coated		サメット Cermet	超硬合金 Uncoated		適用ホルダ Applicable holder
	JC5040	JC5030	NAT	M	K	
				UMS	DX25	
RPMW-0802MO	●	○	○	<input type="checkbox"/>	<input type="checkbox"/>	1 RCPR-121, 161
RPMW-1003MO	●	○	○	<input type="checkbox"/>	<input type="checkbox"/>	2 RCPR-201
RPMW-1203MO	○	○	○	<input type="checkbox"/>	<input type="checkbox"/>	3 RCPR-251
RPMW-1604MO	○	○	○	<input type="checkbox"/>	<input type="checkbox"/>	4 RCPR-302, 321

### ■部品

クランプネジ Clamp screw	レンチ Wrench	適用ホルダ Applicable holder
ESW-306	A-08	RCPR-121, 161
ESW-406	A-15	RCPR-201, 251
ESW-508	A-25	RCPR-301, 321

### ■使用チップ

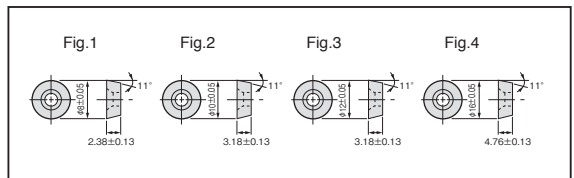

形番 Cat.No.	コーティング Coated		サメット Cermet	超硬合金 Uncoated		適用ホルダ Applicable holder
	JC5040	JC5030	NAT	M	K	
				UMS	DX25	
RPMW-0802MO	●	○	○	<input type="checkbox"/>	<input type="checkbox"/>	1 RCPR-121, 161
RPMW-1003MO	●	○	○	<input type="checkbox"/>	<input type="checkbox"/>	2 RCPR-201
RPMW-1203MO	○	○	○	<input type="checkbox"/>	<input type="checkbox"/>	3 RCPR-251
RPMW-1604MO	○	○	○	<input type="checkbox"/>	<input type="checkbox"/>	4 RCPR-302, 321

### ■部品

クランプネジ Clamp screw	レンチ Wrench	適用ホルダ Applicable holder
ESW-306	A-08	RCPR-121, 161
ESW-406	A-15	RCPR-201, 251
ESW-508	A-25	RCPR-301, 321

## Rチップー RCPR-2-BT30形

●BT-30シャンク形  
2枚刃



### ■本体

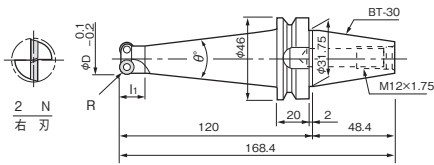

形番 Cat. No.	在庫 Stock	寸法 (mm) Dimensions (mm)		
		φD	R	l <sub>1</sub>
RCPR-202-08-BT30	<input type="checkbox"/>	20	4	20
RCPR-252-10-BT30	<input type="checkbox"/>	25	5	24
RCPR-302-10-BT30	<input type="checkbox"/>	30	5	24
RCPR-302-12-BT30	<input type="checkbox"/>	30	6	24
RCPR-322-12-BT30	<input type="checkbox"/>	32	6	24

本体にチップは組込んでありません。

## Rチップー RCPR-2-BT40形

●BT-40シャンク形  
2枚刃



### ■本体

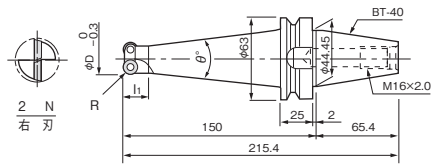

形番 Cat. No.	在庫 Stock	寸法 (mm) Dimensions (mm)		
		φD	R	l <sub>1</sub>
RCPR-202-08-BT40	<input type="checkbox"/>	20	4	20
RCPR-252-10-BT40	<input type="checkbox"/>	25	5	24
RCPR-302-10-BT40	<input type="checkbox"/>	30	5	24
RCPR-302-12-BT40	<input type="checkbox"/>	30	6	24
RCPR-322-12-BT40	<input type="checkbox"/>	32	6	24
RCPR-402-12-BT40	<input type="checkbox"/>	40	6	24
RCPR-402-16-BT40	<input type="checkbox"/>	40	8	24

本体にチップは組込んでありません。

### ■使用チップ

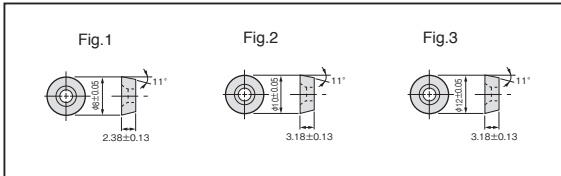

形番 Cat.No.	コーティング Coated		サメット Cermet	超硬合金 Uncoated			Fig.	適用ホルダ Applicable holder
	JC5040	JC5030	NAT	M	K	UMS DX25 KT9		
RPMW-0802MO	●	○	○	<input type="checkbox"/>	<input type="checkbox"/>		1	RCPR-202
RPMW-1003MO	●	○	○	<input type="checkbox"/>	<input type="checkbox"/>		2	RCPR-252-10,302-1
RPMW-1203MO		○	○	<input type="checkbox"/>	<input type="checkbox"/>		3	RCPR-302-12

### ■部品

クランプネジ Clamp screw	レンチ Wrench	適用ホルダ Applicable holder
ESW-306	A-08	RCPR-202
ESW-406	A-15	RCPR-252,302,322

91

### ■使用チップ

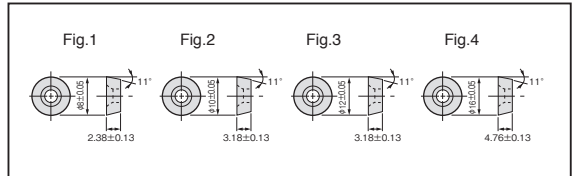

形番 Cat.No.	コーティング Coated		サメット Cermet	超硬合金 Uncoated			Fig.	適用ホルダ Applicable holder
	JC5040	JC5030	NAT	M	K	UMS DX25 KT9		
RPMW-0802MO	●	○	○	<input type="checkbox"/>	<input type="checkbox"/>		1	RCPR-202
RPMW-1003MO	●	○	○	<input type="checkbox"/>	<input type="checkbox"/>		2	RCPR-252-10,302-1
RPMW-1203MO		○	○	<input type="checkbox"/>	<input type="checkbox"/>		3	RCPR-302-12,322-12,402-12
RPMW-1604MO				<input type="checkbox"/>	<input type="checkbox"/>		4	RCPR-402-16

### ■部品

クランプネジ Clamp screw	レンチ Wrench	適用ホルダ Applicable holder
ESW-306	A-08	RCPR-202
ESW-406	A-15	RCPR-252,302,322
ESW-410	A-15	RCPR-402-12
ESW-508	A-25	RCPR-402-16

71

## Rチップー ZPR-0202形

- ストレートシャンク形  
2枚刃、不等分割



### ■本体

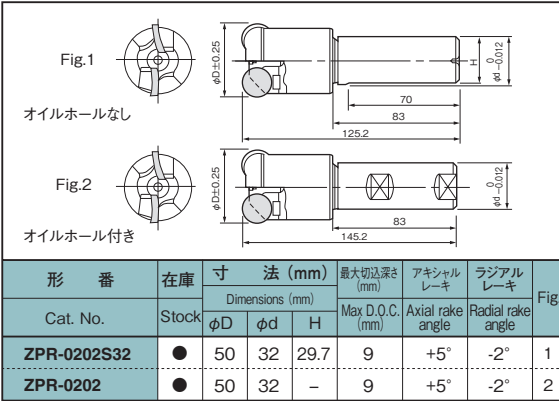

本体にチップは組込んでありません。

## Rチップー ZPR-0203形 ロングシャンク

- ストレートシャンク形  
3枚刃、オイルホール付き

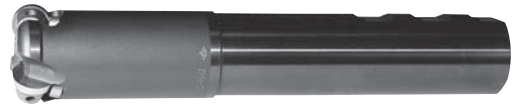

### ■本体

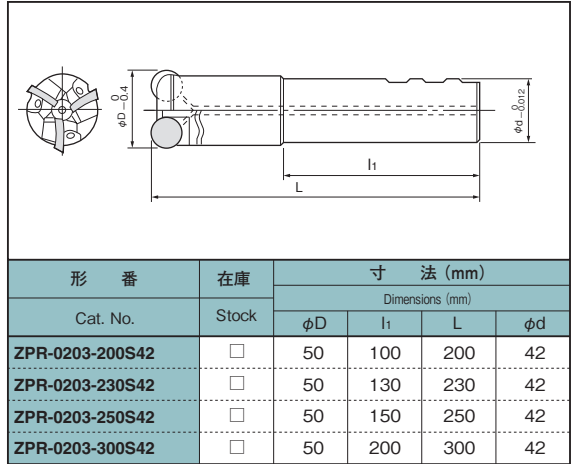

本体にチップは組込んでありません。

## Rチップー ZPR-0203形

- ストレートシャンク形  
3枚刃



### ■本体

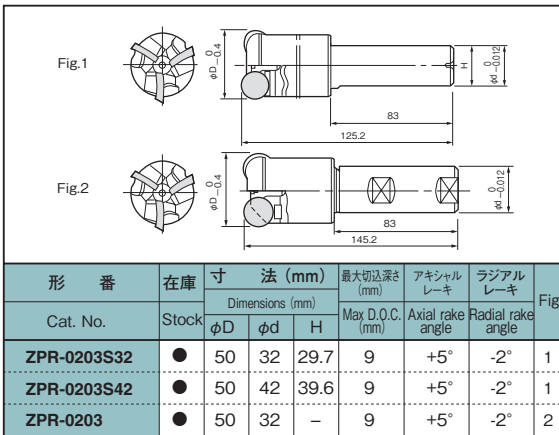

本体にチップは組込んでありません。

### ■使用チップ

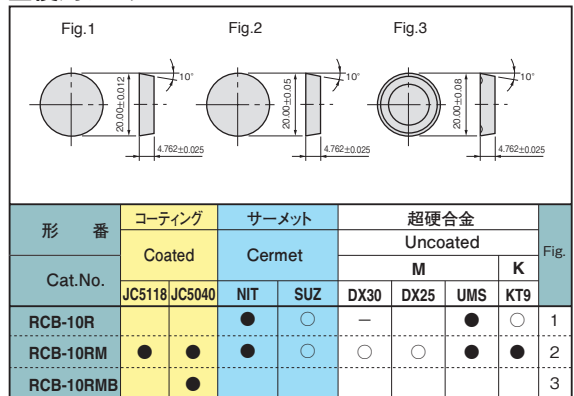

### ■部品

ウェッジ	レストボタン	ウェッジスクリュー	レストボタンスクリュー	Tレンチ
Wedge	Rest button	Wedge screw	Rest button screw	Wrench
60909-SP328	RB-13	LS-143	LS-113	A-036

## 柄付きカッタ PNS-0203形

- ストレートシャンク形  
3枚刃、コーナ角 30°



### ■本体

Fig.1

形番 Cat. No.	在庫 Stock	寸法 (mm) Dimensions (mm)			アキシヤル レーキ Axial rake angle	ラジアル レーキ Radial rake angle	Fig.
		φD	φd	H			
PNS-0203S32	□	50	32	29.7	-5°	-10°	1
PNS-0203S42	□	50	42	39.6	-5°	-10°	1

本体にチップは組込んでありません。

## ハイレーキカッタ HR2L-0203形

- アルミニウム、軟質合金加工用  
3枚刃



### ■本体

Fig.1

形番 Cat. No.	在庫 Stock	寸法 (mm) Dimensions (mm)			最大切込 深さ Max. D.O.C (mm)	アキシヤル レーキ Axial rake angle	ラジアル レーキ Radial rake angle
		φD	φd	H			
HR2L-0203S32	●	50	32	29.7	9	+10°30'	+6°30'

本体にチップは組込んでありません。

### ■使用チップ

Fig.1 Fig.2 Fig.3

形番 Cat. No.	コーティング	サーメット			超硬合金	内接円		最大 切込み 深さ Max. D.O.C.	Fig.
	Coated	SC30	NIT	SUZ	Uncoated K	I.C.	許容差		
PNNY-543	●	●	○	○	□	16.28±0.05	8	1	
PNNY-54W	●	●	●	●	●	16.28±0.05	7	2	
PNGY-54W	●	●	●	●	●	15.88±0.01	7	2	
PNNY-543R	○	●	●	●	●	16.28±0.05	5	3	

### ■使用チップ

Fig.1

形番 Cat. No.	超硬合金
	Uncoated
PNNY-543	□
PNNY-54W	●
PNGY-54W	●
PNNY-543R	○

### ■部品

ウェッジ	レストボタン	ウェッジスクリュー	レストボタンスクリュー	Tレンチ
Wedge	Rest button	Wedge screw	Rest button screw	Wrench
A8110-6	RB-13	LS-160	LS-113	A-040

### ■部品

ウェッジ	レストボタン	ウェッジスクリュー	レストボタンスクリュー	Tレンチ
Wedge	Rest button	Wedge screw	Rest button screw	Wrench
60705-1	RB-14	LS-101	LS-113	A-030

## 柄付きカッタ LC90P-0203形

- ストレートシャンク形  
3枚刃、不等分割  
コーナ角 0°

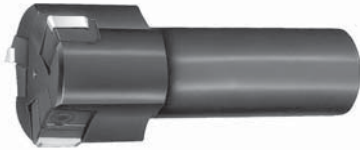

### ■本体

形番	在庫	寸法 (mm)			最大切込深さ (mm)	アキシャルレーキ	ラジアルレーキ
		Dimensions (mm)					
Cat. No.	Stock	$\phi D$	$\phi d$	H	Max D.O.C. (mm)	Axial rake angle	Radial rake angle
LC90P-0203S32	●	50	32	29.7	12	+2°	+2°45'

本体にチップは組込んでありません。

## 柄付きカッタ ZNP90S-0203形

- ストレートシャンク形  
3枚刃、コーナ角 0°



### ■本体

形番	在庫	寸法 (mm)			最大切込深さ (mm)	アキシャルレーキ	ラジアルレーキ
		Dimensions (mm)					
Cat. No.	Stock	$\phi D$	$\phi d$	H	Max D.O.C. (mm)	Axial rake angle	Radial rake angle
ZNP90S-0203S32	○	50	32	29.7	14	+7°	-6°30'

本体にチップは組込んでありません。

### ■使用チップ

Fig.1		Fig.2			
形番	サーメット		超硬合金		Fig.
	Cermet		Uncoated		
Cat.No.	NIT		M	K	
			UMS	KT9	
T36P-Y4E	●	○	●	●	1
T36P-Y4L	●	●	●	●	2

### ■使用チップ

形番	サーメット		超硬合金		
	Cermet		Uncoated		
Cat.No.	NIT		K		
			KT9		
S56P-R3G	●	●	●	●	

### ■部品

ウェッジ	ロケータ	ウェッジスクリュー	ロケータスクリュー	Tレンチ
Wedge	Locator	Wedge screw	Locator screw	Wrench
71007-1R	LCP-10R	LS-180	M2x0.4x6	A-27

71

### ■部品

ウェッジ	レストボタン	ウェッジスクリュー	レストボタンスクリュー	Tレンチ
Wedge	Rest button	Wedge screw	Rest button screw	Wrench
60808-1	RB-13	LS-140	LS-113	A-036

81



# アジャスタブルカッタ ACTPR形

- ストレートシャンク形  
1枚刃、角度可変式(0°~60°)(1目盛あたり5°)



## ■ 本体

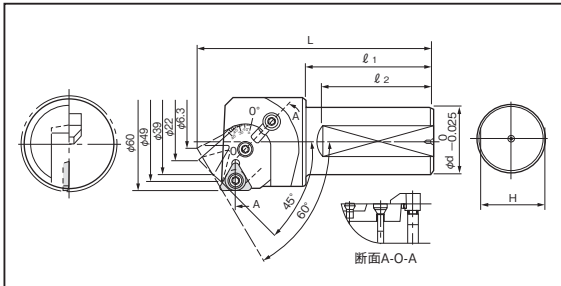

形番 Cat. No.	在庫 Stock	刃数 No. of inserts	寸法 (mm) Dimensions (mm)			
			φD1	L	φd	H
ACTPR-061S32	●	1	60	150	32	29.7
ACTPR-061S42	●	1	60	150	42	39.6

本体にチップは組込んでありません。

## ■ 使用チップ

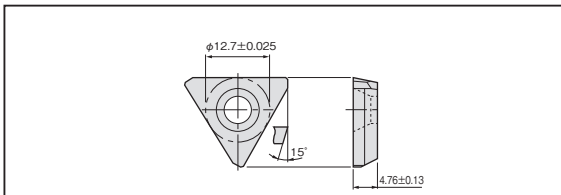

形番 Cat.No.	サーメット	超硬合金	
	Cermet	Uncoated	
		M	K
TPGW2204PDR-AC	●	○	●

## ■ 部品

チップ締めネジ Clamp screw for insert	ロケータ Locator	ロケータネジ Locator screw	クランプ Clamp	クランプネジ Clamp screw	レンチ Wrench
HSW-513-1	LCP-12R	HSW-517	DCM-3	LS-180	A-27

一般&難削材・  
平面削り用

# フェザーミル・タフ

# HSG45-5000形

- 鋼、ステンレス鋼、鋳鉄、アルミ等の汎用、重切削可能  
高送り用チップR5付き使用可  
驚異の切りくず排出量を実現!

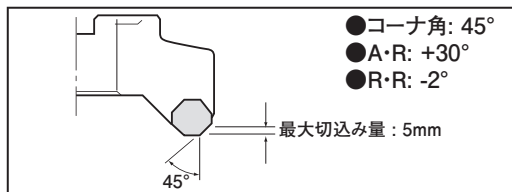

## ■本体／穴径インチサイズ

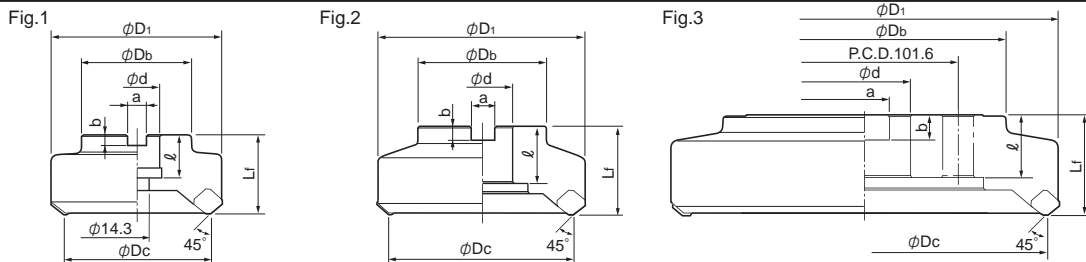

形番	在庫	刃数	寸法 (mm)								Fig.	重量 (kg)
			φDc	φD1	φDb	Lf	φd	a	b	ℓ		
HSG45-5080R	●	4	80	93	60	44	25.4	9.5	6	24	1	1.6
HSG45-5100R	●	5	100	113	70	50	31.75	12.7	8	32	2	2.5
HSG45-5125R	●	6	125	138	80	54	38.1	15.9	10	36	2	4.0
HSG45-5160R	●	8	160	173	100	56	50.8	19	11	37	2	6.2
HSG45-5200R	●	10	200	213	154	56	47.625	25.4	14.3	34.5	3	9.9
HSG45-5250R	●	12	250	263	154	56	47.625	25.4	14.3	34.5	3	13.6

注) 本体にチップは組込んでありません。

## ■部品

ウェッジ	ウェッジスクリュー	レンチ
	推奨トルク8.0N・m	
80808-5	LS-180	A-27

## ■対応チップ

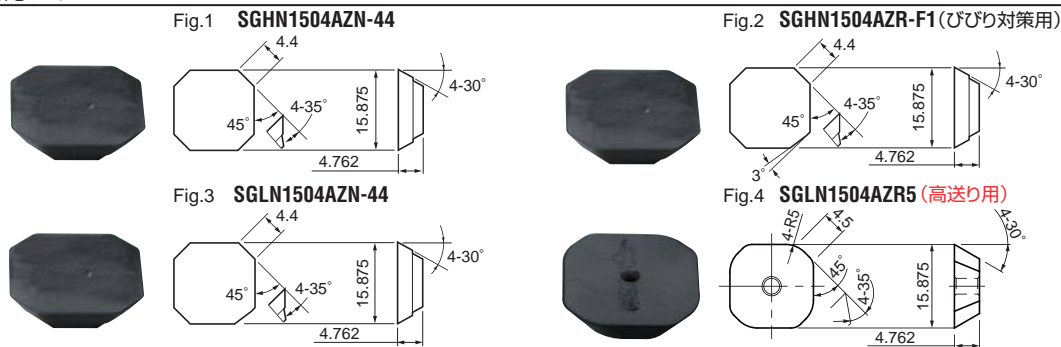

形番	PVDコーティング				CVDコーティング		サーメット	超硬合金	精度	Fig.
	JC5118	JC5030	JC5040	JC5080	JC730U	JC610	CX90	KT9		
SGHN1504AZN-44		○	●		●	●	●	●	H	1
SGHN1504AZR-F1	●	○	●			●	●		H	2
SGLN1504AZN-44		○							L	3
SGLN1504AZR5			●	●					L	4

1ケース10個入りです。

●:メーカー在庫 □:流通在庫 ☆:海外在庫 ◎:近日在庫 ○:在庫がなくなり次第廃番

# Dijet-mill ダイジェットミル アルミ加工用 HR2L形

●アルミ合金、軟質合金加工専用

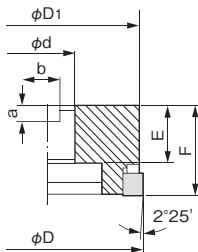
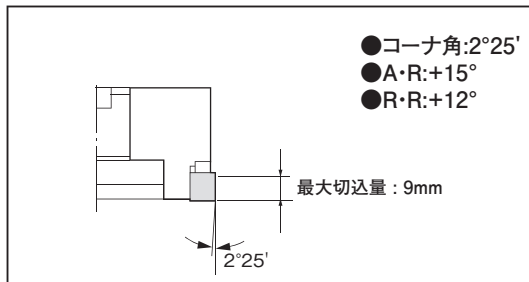

形番	在庫	刃数	寸法 (mm)						
			Dimensions (mm)						
Cat. No.	Stock	No. of inserts	φD	φD <sub>1</sub>	F	φd	a	b	E
HR2L-0506R	○	6	127	127	58	38.1	10	15.9	38
HR2L-0608R	○	8	152	152	58	50.8	11	19	38
HR2L-0612R	○	12	152	152	58	50.8	11	19	38

本体にチップは組込んでありません。

### ■使用チップ

形番	超硬合金		
Cat.No.	Uncoated		
S44E-W2E	●	□	☆

### ■部品

ウェッジ	レストボタン	ウェッジスクリュー	レストボタンスクリュー	Tレンチ
Wedge	Rest button	Wedge screw	Rest button screw	Wrench
A60808-1	RB-14	LS-140	LS-113	A-036

### ■推奨切削条件

被削材	切削速度 (m/min)	送り (mm/刃)	チップ材種
Work materials	Cutting speed (m/min)	feed rate (mm/tooth)	Recommend insert grades
アルミ合金、軟質合金 Aluminum & other soft materials	300~1000	0.1~0.3	KT9

# Dijet-mill ダイジェットミル PNS形

●鋼、鋳鉄の汎用、チップの10コーナが使えて経済的

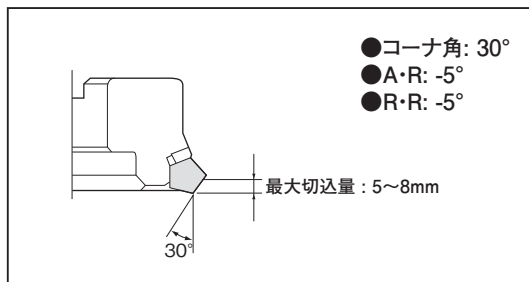

## ■本体

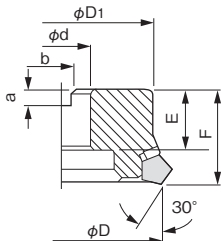

形番 Cat. No.	在庫 Stock	刃数 No. of inserts	寸法 (mm) Dimensions (mm)							
			φD	φD <sub>1</sub>	F	φd	a	b	E	t
PNS-0405R	●	5	100	85	50	31.75	8	12.7	32	-
PNS-0506R	●	6	125	107	58	38.1	10	15.9	38	-
PNS-0608R	●	8	150	132	58	50.8	11	19.0	38	-

本体にチップは組込んでありません。

## ■使用チップ



形番 Cat.No.	コーティング Coated				サーメット Cermet				超硬合金 Uncoated		寸法 Dimensions(mm)	Fig.	形番 Cat.No.	サーメット Cermet		寸法 Dimensions(mm)		Fig.
	JC3552	SC30	NIT	SUZ	KT9	A	NIT	A										
PNNY-543			●	○	□	16.28	1	PNNY-54WL	□	16.28	4							
PNNY-54W		●	●		●	16.28	2											
PNGY-54W					●	15.88	2											
PNNY-543R	○					16.28	3											

## ■部品

ウェッジ Wedge	レストボタン Rest button	ウェッジ スクリュー Wedge screw	レストボタン スクリュー Rest button screw	Tレンチ Wrench
A8110-5	RB-13	LS-160	LS-113	A-040

## ■推奨切削条件

被削材 Work materials	切削速度 (m/min) Cutting speed (m/min)	送り (mm/刃) feed rate (mm/tooth)	チップ材種 Recommend insert grades
炭素鋼 Carbon steel	120~200	0.1~0.3	NIT, SUZ
合金鋼 Alloy steel	60~90	0.1~0.25	NIT, SUZ
鋳鋼 Cast steel	150	0.2	NIT, SUZ
鋳鉄 Cast iron	80~120	0.1~0.25	KT9, UMS

# DZ-COAT ソリッドエンドミル

# DZ-DES2-S形

- 2枚刃標準刃長
- 超ミニチュアタイプ

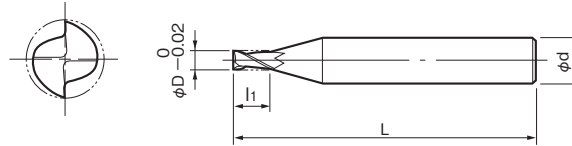

材種: DZコート(TiAIN系)

形番	在庫	寸法 (mm)			
		φD	l <sub>1</sub>	L	φd
DZ-DES2-0020S	<input type="checkbox"/>	0.2	0.4	40	3
DZ-DES2-0030S	<input type="checkbox"/>	0.3	1	40	3
DZ-DES2-0040S	<input type="checkbox"/>	0.4	1.2	40	3
DZ-DES2-0050S	<input type="checkbox"/>	0.5	1.5	40	3
DZ-DES2-0060S	<input type="checkbox"/>	0.6	2	40	3
DZ-DES2-0070S	<input type="checkbox"/>	0.7	2	40	3
DZ-DES2-0080S	<input type="checkbox"/>	0.8	2.5	40	3
DZ-DES2-0090S	<input type="checkbox"/>	0.9	2.5	40	3
DZ-DES2-0100S	<input type="checkbox"/>	1	3	40	4
DZ-DES2-0110S	<input type="checkbox"/>	1.1	3	40	4
DZ-DES2-0120S	<input type="checkbox"/>	1.2	3	40	4
DZ-DES2-0130S	<input type="checkbox"/>	1.3	3	40	4
DZ-DES2-0140S	<input type="checkbox"/>	1.4	3	40	4
DZ-DES2-0150S	<input type="checkbox"/>	1.5	5	40	4
DZ-DES2-0160S	<input type="checkbox"/>	1.6	5	40	4
DZ-DES2-0170S	<input type="checkbox"/>	1.7	5	40	4
DZ-DES2-0180S	<input type="checkbox"/>	1.8	5	40	4
DZ-DES2-0190S	<input type="checkbox"/>	1.9	5	40	4
DZ-DES2-0200S	<input type="checkbox"/>	2	6	40	4
DZ-DES2-0210S	<input type="checkbox"/>	2.1	6	40	4
DZ-DES2-0220S	<input type="checkbox"/>	2.2	6	40	4
DZ-DES2-0230S	<input type="checkbox"/>	2.3	6	40	4
DZ-DES2-0240S	<input type="checkbox"/>	2.4	6	40	4
DZ-DES2-0250S	<input type="checkbox"/>	2.5	8	40	4
DZ-DES2-0260S	<input type="checkbox"/>	2.6	8	40	4
DZ-DES2-0270S	<input type="checkbox"/>	2.7	8	40	4
DZ-DES2-0280S	<input type="checkbox"/>	2.8	8	40	4
DZ-DES2-0290S	<input type="checkbox"/>	2.9	8	40	4
DZ-DES2-0300S	<input type="checkbox"/>	3	8	45	6
DZ-DES2-0310S	<input type="checkbox"/>	3.1	8	45	6
DZ-DES2-0320S	<input type="checkbox"/>	3.2	8	45	6
DZ-DES2-0330S	<input type="checkbox"/>	3.3	8	45	6
DZ-DES2-0340S	<input type="checkbox"/>	3.4	8	45	6
DZ-DES2-0350S	<input type="checkbox"/>	3.5	10	45	6
DZ-DES2-0360S	<input type="checkbox"/>	3.6	10	45	6
DZ-DES2-0370S	<input type="checkbox"/>	3.7	10	45	6
DZ-DES2-0380S	<input type="checkbox"/>	3.8	10	45	6
DZ-DES2-0390S	<input type="checkbox"/>	3.9	10	45	6
DZ-DES2-0400S	<input type="checkbox"/>	4	12	45	6
DZ-DES2-0410S	<input type="checkbox"/>	4.1	12	45	6
DZ-DES2-0420S	<input type="checkbox"/>	4.2	12	45	6
DZ-DES2-0430S	<input type="checkbox"/>	4.3	12	45	6
DZ-DES2-0440S	<input type="checkbox"/>	4.4	12	45	6
DZ-DES2-0450S	<input type="checkbox"/>	4.5	12	45	6
DZ-DES2-0460S	<input type="checkbox"/>	4.6	12	45	6
DZ-DES2-0470S	<input type="checkbox"/>	4.7	12	45	6
DZ-DES2-0480S	<input type="checkbox"/>	4.8	12	45	6
DZ-DES2-0490S	<input type="checkbox"/>	4.9	12	45	6
DZ-DES2-0500S	<input type="checkbox"/>	5	15	60	6
DZ-DES2-0510S	<input type="checkbox"/>	5.1	15	60	6
DZ-DES2-0520S	<input type="checkbox"/>	5.2	15	60	6
DZ-DES2-0530S	<input type="checkbox"/>	5.3	15	60	6
DZ-DES2-0540S	<input type="checkbox"/>	5.4	15	60	6
DZ-DES2-0550S	<input type="checkbox"/>	5.5	15	60	6
DZ-DES2-0560S	<input type="checkbox"/>	5.6	15	60	6
DZ-DES2-0570S	<input type="checkbox"/>	5.7	15	60	6
DZ-DES2-0580S	<input type="checkbox"/>	5.8	15	60	6
DZ-DES2-0590S	<input type="checkbox"/>	5.9	15	60	6
DZ-DES2-0600S	<input type="checkbox"/>	6	15	60	6

## DZ-COAT ソリッドエンドミル

## DZ-DES2-L形

- 2枚刃ロング刃長
- 超ミニチュアタイプ

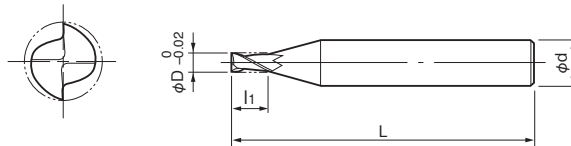

材種: DZコート(TiAIN系)

形番	在庫	寸法(mm)				形番	在庫	寸法(mm)			
		φD	l <sub>1</sub>	L	φd			φD	l <sub>1</sub>	L	φd
DZ-DES2-0020L	<input type="checkbox"/>	0.2	1.5	40	3	DZ-DES2-0170L	<input type="checkbox"/>	1.7	10	40	4
DZ-DES2-0030L	<input type="checkbox"/>	0.3	2	40	3	DZ-DES2-0180L	<input type="checkbox"/>	1.8	10	40	4
DZ-DES2-0040L	<input type="checkbox"/>	0.4	2.5	40	3	DZ-DES2-0190L	<input type="checkbox"/>	1.9	10	40	4
DZ-DES2-0050L	<input type="checkbox"/>	0.5	3	40	3	DZ-DES2-0200L-10	<input type="checkbox"/>	2	10	40	4
DZ-DES2-0060L	<input type="checkbox"/>	0.6	3.5	40	3	DZ-DES2-0200L-12	<input type="checkbox"/>	2	12	40	4
DZ-DES2-0070L	<input type="checkbox"/>	0.7	4.5	40	3	DZ-DES2-0200L-15	<input type="checkbox"/>	2	15	45	4
DZ-DES2-0080L	<input type="checkbox"/>	0.8	5	40	3	DZ-DES2-0200L-20	<input type="checkbox"/>	2	20	55	4
DZ-DES2-0090L	<input type="checkbox"/>	0.9	5.5	40	3	DZ-DES2-0210L	<input type="checkbox"/>	2.1	15	45	4
DZ-DES2-0100L-5	<input type="checkbox"/>	1	5	40	4	DZ-DES2-0220L	<input type="checkbox"/>	2.2	15	45	4
DZ-DES2-0100L-6	<input type="checkbox"/>	1	6	40	4	DZ-DES2-0230L	<input type="checkbox"/>	2.3	15	45	4
DZ-DES2-0100L-7.5	<input type="checkbox"/>	1	7.5	40	4	DZ-DES2-0240L	<input type="checkbox"/>	2.4	15	45	4
DZ-DES2-0100L-10	<input type="checkbox"/>	1	10	40	4	DZ-DES2-0250L-15	<input type="checkbox"/>	2.5	15	50	4
DZ-DES2-0110L	<input type="checkbox"/>	1.1	7.5	40	4	DZ-DES2-0250L-20	<input type="checkbox"/>	2.5	20	55	4
DZ-DES2-0120L	<input type="checkbox"/>	1.2	7.5	40	4	DZ-DES2-0260L	<input type="checkbox"/>	2.6	15	50	4
DZ-DES2-0130L	<input type="checkbox"/>	1.3	8	40	4	DZ-DES2-0270L	<input type="checkbox"/>	2.7	15	50	4
DZ-DES2-0140L	<input type="checkbox"/>	1.4	8.5	40	4	DZ-DES2-0280L	<input type="checkbox"/>	2.8	15	50	4
DZ-DES2-0150L-10	<input type="checkbox"/>	1.5	10	40	4	DZ-DES2-0290L	<input type="checkbox"/>	2.9	15	50	4
DZ-DES2-0150L-15	<input type="checkbox"/>	1.5	15	45	4	DZ-DES2-0300L-20	<input type="checkbox"/>	3	20	55	4
DZ-DES2-0160L	<input type="checkbox"/>	1.6	10	40	4	DZ-DES2-0300L-25	<input type="checkbox"/>	3	25	70	4
						DZ-DES2-0300L-30	<input type="checkbox"/>	3	30	70	4

74

# DX-COAT ソリッドワンカットエンドミル

# OCES2-S-D形

- 2枚刃標準刃長、中心刃付き、0.1シリーズ  
エキセントリックリリーフ形、ねじれ角30°

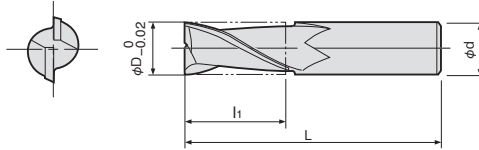

材種: DXコート(TICN系)

形番 Cat. No.	在庫 Stock	寸法 (mm) Dimensions (mm)				形番 Cat. No.	在庫 Stock	寸法 (mm) Dimensions (mm)			
		φD	l1	L	φd			φD	l1	L	φd
OCES2-010S-D	<input type="checkbox"/>	1	2.5	40	4	OCES2-0010S-D	<input type="checkbox"/>	0.1	0.2	40	3
OCES2-015S-D	<input type="checkbox"/>	1.5	4	40	4	OCES2-0020S-D	<input type="checkbox"/>	0.2	0.4	40	3
OCES2-020S-D	<input type="checkbox"/>	2	6	40	4	OCES2-0030S-D	<input type="checkbox"/>	0.3	0.6	40	3
OCES2-025S-D	<input type="checkbox"/>	2.5	8	40	4	OCES2-0040S-D	<input type="checkbox"/>	0.4	0.8	40	3
OCES2-030S-D	<input type="checkbox"/>	3	10	45	6	OCES2-0050S-D	<input type="checkbox"/>	0.5	1	40	3
OCES2-035S-D	<input type="checkbox"/>	3.5	11	45	6	OCES2-0060S-D	<input type="checkbox"/>	0.6	1.2	40	3
OCES2-040S-D	<input type="checkbox"/>	4	12	45	6	OCES2-0070S-D	<input type="checkbox"/>	0.7	1.4	40	3
OCES2-045S-D	<input type="checkbox"/>	4.5	14	45	6	OCES2-0080S-D	<input type="checkbox"/>	0.8	1.6	40	3
OCES2-050S-D	<input type="checkbox"/>	5	15	50	6	OCES2-0090S-D	<input type="checkbox"/>	0.9	2	40	3
OCES2-055S-D	<input type="checkbox"/>	5.5	15	50	6	OCES2-0110S-D	<input type="checkbox"/>	1.1	2.5	40	4
OCES2-060S-D	<input type="checkbox"/>	6	15	50	6	OCES2-0120S-D	<input type="checkbox"/>	1.2	2.5	40	4
OCES2-065S-D	<input type="checkbox"/>	6.5	15	50	6	OCES2-0130S-D	<input type="checkbox"/>	1.3	2.5	40	4
OCES2-070S-D	<input type="checkbox"/>	7	20	60	8	OCES2-0140S-D	<input type="checkbox"/>	1.4	2.5	40	4
OCES2-075S-D	<input type="checkbox"/>	7.5	20	60	8	OCES2-0160S-D	<input type="checkbox"/>	1.6	4	40	4
OCES2-080S-D	<input type="checkbox"/>	8	20	60	8	OCES2-0170S-D	<input type="checkbox"/>	1.7	4	40	4
OCES2-085S-D	<input type="checkbox"/>	8.5	20	60	8	OCES2-0180S-D	<input type="checkbox"/>	1.8	4	40	4
OCES2-090S-D	<input type="checkbox"/>	9	20	65	10	OCES2-0190S-D	<input type="checkbox"/>	1.9	4	40	4
OCES2-095S-D	<input type="checkbox"/>	9.5	20	65	10	OCES2-0210S-D	<input type="checkbox"/>	2.1	6	40	4
OCES2-100S-D	<input type="checkbox"/>	10	25	70	10	OCES2-0220S-D	<input type="checkbox"/>	2.2	6	40	4
OCES2-110S-D	<input type="checkbox"/>	11	25	75	12	OCES2-0230S-D	<input type="checkbox"/>	2.3	6	40	4
OCES2-120S-D	<input type="checkbox"/>	12	25	75	12	OCES2-0240S-D	<input type="checkbox"/>	2.4	6	40	4
OCES2-130S-D	<input type="checkbox"/>	13	30	80	12	OCES2-0260S-D	<input type="checkbox"/>	2.6	8	40	4
OCES2-140S-D	<input type="checkbox"/>	14	35	90	16	OCES2-0270S-D	<input type="checkbox"/>	2.7	8	40	4
OCES2-150S-D	<input type="checkbox"/>	15	35	90	16	OCES2-0280S-D	<input type="checkbox"/>	2.8	8	40	4
OCES2-160S-D	<input type="checkbox"/>	16	35	90	16	OCES2-0290S-D	<input type="checkbox"/>	2.9	8	40	4
OCES2-170S-D	<input type="checkbox"/>	17	40	105	20	OCES2-0310S-D	<input type="checkbox"/>	3.1	10	45	6
OCES2-180S-D	<input type="checkbox"/>	18	40	105	20	OCES2-0320S-D	<input type="checkbox"/>	3.2	10	45	6
OCES2-190S-D	<input type="checkbox"/>	19	40	105	20	OCES2-0330S-D	<input type="checkbox"/>	3.3	10	45	6
OCES2-200S-D	<input type="checkbox"/>	20	40	105	20	OCES2-0340S-D	<input type="checkbox"/>	3.4	10	45	6
OCES2-210S-D	<input type="checkbox"/>	21	50	120	25	OCES2-0360S-D	<input type="checkbox"/>	3.6	11	45	6
OCES2-220S-D	<input type="checkbox"/>	22	50	120	25	OCES2-0370S-D	<input type="checkbox"/>	3.7	11	45	6
OCES2-230S-D	<input type="checkbox"/>	23	50	120	25	OCES2-0380S-D	<input type="checkbox"/>	3.8	11	45	6
OCES2-240S-D	<input type="checkbox"/>	24	50	120	25	OCES2-0390S-D	<input type="checkbox"/>	3.9	11	45	6
OCES2-250S-D	<input type="checkbox"/>	25	50	120	25	OCES2-0410S-D	<input type="checkbox"/>	4.1	12	45	6
OCES2-260S-D	<input type="checkbox"/>	26	50	120	25	OCES2-0420S-D	<input type="checkbox"/>	4.2	12	45	6
OCES2-270S-D	<input type="checkbox"/>	27	50	120	25	OCES2-0430S-D	<input type="checkbox"/>	4.3	12	45	6
OCES2-280S-D	<input type="checkbox"/>	28	60	130	25	OCES2-0440S-D	<input type="checkbox"/>	4.4	12	45	6
OCES2-290S-D	<input type="checkbox"/>	29	60	130	25	OCES2-0460S-D	<input type="checkbox"/>	4.6	14	45	6
OCES2-300S-D	<input type="checkbox"/>	30	60	130	32	OCES2-0470S-D	<input type="checkbox"/>	4.7	14	45	6
						OCES2-0480S-D	<input type="checkbox"/>	4.8	14	45	6
						OCES2-0490S-D	<input type="checkbox"/>	4.9	14	45	6

91

91

## DX-COAT ソリッドワンカットエンドミル

## OCES2-S-D形

(前ページの続き)

形番 Cat. No.	在庫 Stock	寸法 (mm) Dimensions (mm)			
		φD	l <sub>1</sub>	L	φd
OCES2-0510S-D	<input type="checkbox"/>	5.1	15	50	6
OCES2-0520S-D	<input type="checkbox"/>	5.2	15	50	6
OCES2-0530S-D	<input type="checkbox"/>	5.3	15	50	6
OCES2-0540S-D	<input type="checkbox"/>	5.4	15	50	6
OCES2-0560S-D	<input type="checkbox"/>	5.6	15	50	6
OCES2-0570S-D	<input type="checkbox"/>	5.7	15	50	6
OCES2-0580S-D	<input type="checkbox"/>	5.8	15	50	6
OCES2-0590S-D	<input type="checkbox"/>	5.9	15	50	6
OCES2-0610S-D	<input type="checkbox"/>	6.1	15	50	6
OCES2-0620S-D	<input type="checkbox"/>	6.2	15	50	6
OCES2-0630S-D	<input type="checkbox"/>	6.3	15	50	6
OCES2-0640S-D	<input type="checkbox"/>	6.4	15	50	6
OCES2-0660S-D	<input type="checkbox"/>	6.6	15	50	6
OCES2-0670S-D	<input type="checkbox"/>	6.7	15	50	6
OCES2-0680S-D	<input type="checkbox"/>	6.8	15	50	6
OCES2-0690S-D	<input type="checkbox"/>	6.9	15	50	6
OCES2-0710S-D	<input type="checkbox"/>	7.1	20	60	8
OCES2-0720S-D	<input type="checkbox"/>	7.2	20	60	8
OCES2-0730S-D	<input type="checkbox"/>	7.3	20	60	8
OCES2-0740S-D	<input type="checkbox"/>	7.4	20	60	8
OCES2-0760S-D	<input type="checkbox"/>	7.6	20	60	8
OCES2-0770S-D	<input type="checkbox"/>	7.7	20	60	8
OCES2-0780S-D	<input type="checkbox"/>	7.8	20	60	8
OCES2-0790S-D	<input type="checkbox"/>	7.9	20	60	8
OCES2-0810S-D	<input type="checkbox"/>	8.1	20	60	8
OCES2-0820S-D	<input type="checkbox"/>	8.2	20	60	8
OCES2-0830S-D	<input type="checkbox"/>	8.3	20	60	8
OCES2-0840S-D	<input type="checkbox"/>	8.4	20	60	8
OCES2-0860S-D	<input type="checkbox"/>	8.6	20	60	8
OCES2-0870S-D	<input type="checkbox"/>	8.7	20	60	8
OCES2-0880S-D	<input type="checkbox"/>	8.8	20	60	8
OCES2-0890S-D	<input type="checkbox"/>	8.9	20	60	8
OCES2-0910S-D	<input type="checkbox"/>	9.1	20	65	10
OCES2-0920S-D	<input type="checkbox"/>	9.2	20	65	10
OCES2-0930S-D	<input type="checkbox"/>	9.3	20	65	10
OCES2-0940S-D	<input type="checkbox"/>	9.4	20	65	10
OCES2-0960S-D	<input type="checkbox"/>	9.6	20	65	10
OCES2-0970S-D	<input type="checkbox"/>	9.7	20	65	10
OCES2-0980S-D	<input type="checkbox"/>	9.8	20	65	10
OCES2-0990S-D	<input type="checkbox"/>	9.9	20	65	10
OCES2-1010S-D	<input type="checkbox"/>	10.1	25	70	10
OCES2-1020S-D	<input type="checkbox"/>	10.2	25	70	10
OCES2-1030S-D	<input type="checkbox"/>	10.3	25	70	10
OCES2-1040S-D	<input type="checkbox"/>	10.4	25	70	10
OCES2-1050S-D	<input type="checkbox"/>	10.5	25	70	10
OCES2-1060S-D	<input type="checkbox"/>	10.6	25	70	10
OCES2-1070S-D	<input type="checkbox"/>	10.7	25	70	10
OCES2-1080S-D	<input type="checkbox"/>	10.8	25	70	10
OCES2-1090S-D	<input type="checkbox"/>	10.9	25	70	10



# DX-COAT ソリッドワンカットエンドミル

# OCES2-S-D形

- 2枚刃標準刃長、中心刃付き、0.05シリーズ、エキセントリックリリーフ形、ねじれ角30°

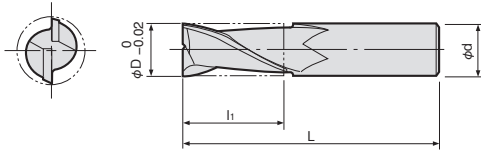

材種:DXコート(TiCN系)

形番 Cat. No.	在庫 Stock	寸法 (mm) Dimensions (mm)			
		φD	l <sub>1</sub>	L	φd
OCES2-0015S-D	☐	0.15	0.3	40	3
OCES2-0025S-D	☐	0.25	0.5	40	3
OCES2-0035S-D	☐	0.35	0.7	40	3
OCES2-0045S-D	☐	0.45	0.9	40	3
OCES2-0055S-D	☐	0.55	1.1	40	3
OCES2-0065S-D	☐	0.65	1.3	40	3
OCES2-0075S-D	☐	0.75	1.5	40	3
OCES2-0085S-D	☐	0.85	1.7	40	3
OCES2-0095S-D	☐	0.95	2	40	3
OCES2-0105S-D	☐	1.05	2.5	40	4
OCES2-0115S-D	☐	1.15	2.5	40	4
OCES2-0125S-D	☐	1.25	2.5	40	4
OCES2-0135S-D	☐	1.35	2.5	40	4
OCES2-0145S-D	☐	1.45	2.5	40	4
OCES2-0155S-D	☐	1.55	4	40	4
OCES2-0165S-D	☐	1.65	4	40	4
OCES2-0175S-D	☐	1.75	4	40	4
OCES2-0185S-D	☐	1.85	4	40	4
OCES2-0195S-D	☐	1.95	4	40	4
OCES2-0205S-D	☐	2.05	6	40	4
OCES2-0215S-D	☐	2.15	6	40	4
OCES2-0225S-D	☐	2.25	6	40	4
OCES2-0235S-D	☐	2.35	6	40	4
OCES2-0245S-D	☐	2.45	6	40	4
OCES2-0255S-D	☐	2.55	8	40	4
OCES2-0265S-D	☐	2.65	8	40	4
OCES2-0275S-D	☐	2.75	8	40	4
OCES2-0285S-D	☐	2.85	8	40	4
OCES2-0295S-D	☐	2.95	8	40	4
OCES2-0305S-D	☐	3.05	10	45	6
OCES2-0315S-D	☐	3.15	10	45	6
OCES2-0325S-D	☐	3.25	10	45	6
OCES2-0335S-D	☐	3.35	10	45	6
OCES2-0345S-D	☐	3.45	10	45	6
OCES2-0355S-D	☐	3.55	11	45	6
OCES2-0365S-D	☐	3.65	11	45	6
OCES2-0375S-D	☐	3.75	11	45	6
OCES2-0385S-D	☐	3.85	11	45	6
OCES2-0395S-D	☐	3.95	11	45	6
OCES2-0405S-D	☐	4.05	12	45	6
OCES2-0415S-D	☐	4.15	12	45	6

形番 Cat. No.	在庫 Stock	寸法 (mm) Dimensions (mm)			
		φD	l <sub>1</sub>	L	φd
OCES2-0425S-D	☐	4.25	12	45	6
OCES2-0435S-D	☐	4.35	12	45	6
OCES2-0445S-D	☐	4.45	12	45	6
OCES2-0455S-D	☐	4.55	14	45	6
OCES2-0465S-D	☐	4.65	14	45	6
OCES2-0475S-D	☐	4.75	14	45	6
OCES2-0485S-D	☐	4.85	14	45	6
OCES2-0495S-D	☐	4.95	14	45	6
OCES2-0505S-D	☐	5.05	15	50	6
OCES2-0515S-D	☐	5.15	15	50	6
OCES2-0525S-D	☐	5.25	15	50	6
OCES2-0535S-D	☐	5.35	15	50	6
OCES2-0545S-D	☐	5.45	15	50	6
OCES2-0555S-D	☐	5.55	15	50	6
OCES2-0565S-D	☐	5.65	15	50	6
OCES2-0575S-D	☐	5.75	15	50	6
OCES2-0585S-D	☐	5.85	15	50	6
OCES2-0595S-D	☐	5.95	15	50	6
OCES2-0605S-D	☐	6.05	15	50	6
OCES2-0615S-D	☐	6.15	15	50	6
OCES2-0625S-D	☐	6.25	15	50	6
OCES2-0635S-D	☐	6.35	15	50	6
OCES2-0645S-D	☐	6.45	15	50	6
OCES2-0655S-D	☐	6.55	15	50	6
OCES2-0665S-D	☐	6.65	15	50	6
OCES2-0675S-D	☐	6.75	15	50	6
OCES2-0685S-D	☐	6.85	15	50	6
OCES2-0695S-D	☐	6.95	15	50	6
OCES2-0705S-D	☐	7.05	20	60	8
OCES2-0715S-D	☐	7.15	20	60	8
OCES2-0725S-D	☐	7.25	20	60	8
OCES2-0735S-D	☐	7.35	20	60	8
OCES2-0745S-D	☐	7.45	20	60	8
OCES2-0755S-D	☐	7.55	20	60	8
OCES2-0765S-D	☐	7.65	20	60	8
OCES2-0775S-D	☐	7.75	20	60	8
OCES2-0785S-D	☐	7.85	20	60	8
OCES2-0795S-D	☐	7.95	20	60	8
OCES2-0805S-D	☐	8.05	20	60	8
OCES2-0815S-D	☐	8.15	20	60	8
OCES2-0825S-D	☐	8.25	20	60	8
OCES2-0835S-D	☐	8.35	20	60	8
OCES2-0845S-D	☐	8.45	20	60	8
OCES2-0855S-D	☐	8.55	20	60	8
OCES2-0865S-D	☐	8.65	20	60	8
OCES2-0875S-D	☐	8.75	20	60	8
OCES2-0885S-D	☐	8.85	20	60	8
OCES2-0895S-D	☐	8.95	20	60	8
OCES2-0905S-D	☐	9.05	20	65	10
OCES2-0915S-D	☐	9.15	20	65	10

## DX-COAT ソリッドワンカットエンドミル OCES2-S-D形

## DX-COAT ソリッドワンカットエンドミル OCES2-L-D形

- 2枚刃ロング刃長、中心刃付き、エキセントリックリリーフ形、ねじれ角30°



(前ページの続き)

形番 Cat. No.	在庫 Stock	寸法(mm) Dimensions(mm)			
		φD	l <sub>1</sub>	L	φd
OCES2-0925S-D	□	9.25	20	65	10
OCES2-0935S-D	□	9.35	20	65	10
OCES2-0945S-D	□	9.45	20	65	10
OCES2-0955S-D	□	9.55	20	65	10
OCES2-0965S-D	□	9.65	20	65	10
OCES2-0975S-D	□	9.75	20	65	10
OCES2-0985S-D	□	9.85	20	65	10
OCES2-0995S-D	□	9.95	20	65	10
OCES2-1005S-D	□	10.05	25	70	10
OCES2-1015S-D	□	10.15	25	70	10
OCES2-1025S-D	□	10.25	25	70	10
OCES2-1035S-D	□	10.35	25	70	10
OCES2-1045S-D	□	10.45	25	70	10
OCES2-1055S-D	□	10.55	25	70	10
OCES2-1065S-D	□	10.65	25	70	10
OCES2-1075S-D	□	10.75	25	70	10
OCES2-1085S-D	□	10.85	25	70	10
OCES2-1095S-D	□	10.95	25	70	10
OCES2-1105S-D	□	11.05	25	75	12
OCES2-1110S-D	□	11.1	25	75	12
OCES2-1115S-D	□	11.15	25	75	12
OCES2-1120S-D	□	11.2	25	75	12
OCES2-1125S-D	□	11.25	25	75	12
OCES2-1130S-D	□	11.3	25	75	12
OCES2-1135S-D	□	11.35	25	75	12
OCES2-1140S-D	□	11.4	25	75	12
OCES2-1145S-D	□	11.45	25	75	12
OCES2-1150S-D	□	11.5	25	75	12
OCES2-1155S-D	□	11.55	25	75	12
OCES2-1160S-D	□	11.6	25	75	12
OCES2-1165S-D	□	11.65	25	75	12
OCES2-1170S-D	□	11.7	25	75	12
OCES2-1175S-D	□	11.75	25	75	12
OCES2-1180S-D	□	11.8	25	75	12
OCES2-1185S-D	□	11.85	25	75	12
OCES2-1190S-D	□	11.9	25	75	12
OCES2-1195S-D	□	11.95	25	75	12

材種: DXコート(TICN系)

形番 Cat. No.	在庫 Stock	寸法(mm) Dimensions(mm)			
		φD	l <sub>1</sub>	L	φd
OCES2-030L-D	□	3	20	60	6
OCES2-035L-D	□	3.5	22	60	6
OCES2-040L-D	□	4	24	60	6
OCES2-045L-D	□	4.5	28	60	6
OCES2-050L-D	□	5	30	70	6
OCES2-055L-D	□	5.5	30	70	6
OCES2-060L-D	□	6	30	70	6
OCES2-065L-D	□	6.5	40	90	8
OCES2-070L-D	□	7	40	90	8
OCES2-075L-D	□	7.5	40	90	8
OCES2-080L-D	□	8	40	90	8
OCES2-085L-D	□	8.5	40	100	10
OCES2-090L-D	□	9	40	100	10
OCES2-095L-D	□	9.5	40	100	10
OCES2-100L-D	□	10	50	110	10
OCES2-110L-D	□	11	50	110	12
OCES2-120L-D	□	12	50	110	12
OCES2-130L-D	□	13	60	120	12
OCES2-140L-D	□	14	70	130	16
OCES2-150L-D	□	15	70	130	16
OCES2-160L-D	□	16	70	130	16
OCES2-170L-D	□	17	70	140	20
OCES2-180L-D	□	18	70	140	20
OCES2-190L-D	□	19	70	140	20
OCES2-200L-D	□	20	70	140	20
OCES2-210L-D	□	21	80	150	25
OCES2-220L-D	□	22	80	150	25
OCES2-230L-D	□	23	80	150	25
OCES2-240L-D	□	24	80	150	25
OCES2-250L-D	□	25	80	150	25

# DX-COAT ソリッドワンカットエンドミル

# OCES4-S-D形

- 4枚刃標準刃長、中心刃付き、O.1シリーズ  
エキセントリックリリーフ形、ねじれ角30°

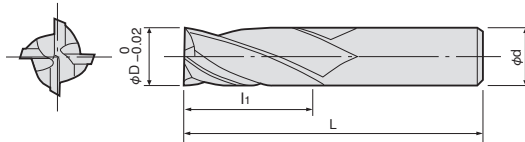

材種: DXコート(TICN系)

形番 Cat. No.	在庫 Stock	寸法 (mm) Dimensions (mm)			
		φD	l <sub>1</sub>	L	φd
OCES4-030S-D	<input type="checkbox"/>	3	10	45	6
OCES4-035S-D	<input type="checkbox"/>	3.5	11	45	6
OCES4-040S-D	<input type="checkbox"/>	4	12	45	6
OCES4-045S-D	<input type="checkbox"/>	4.5	14	45	6
OCES4-050S-D	<input type="checkbox"/>	5	15	50	6
OCES4-055S-D	<input type="checkbox"/>	5.5	15	50	6
OCES4-060S-D	<input type="checkbox"/>	6	15	50	6
OCES4-065S-D	<input type="checkbox"/>	6.5	15	50	6
OCES4-070S-D	<input type="checkbox"/>	7	20	60	8
OCES4-075S-D	<input type="checkbox"/>	7.5	20	60	8
OCES4-080S-D	<input type="checkbox"/>	8	20	60	8
OCES4-085S-D	<input type="checkbox"/>	8.5	20	60	8
OCES4-090S-D	<input type="checkbox"/>	9	20	65	10
OCES4-095S-D	<input type="checkbox"/>	9.5	20	65	10
OCES4-100S-D	<input type="checkbox"/>	10	25	70	10
OCES4-110S-D	<input type="checkbox"/>	11	25	75	12
OCES4-120S-D	<input type="checkbox"/>	12	25	75	12
OCES4-130S-D	<input type="checkbox"/>	13	30	80	12
OCES4-140S-D	<input type="checkbox"/>	14	35	90	16
OCES4-150S-D	<input type="checkbox"/>	15	35	90	16
OCES4-160S-D	<input type="checkbox"/>	16	35	90	16
OCES4-170S-D	<input type="checkbox"/>	17	40	105	20
OCES4-180S-D	<input type="checkbox"/>	18	40	105	20
OCES4-190S-D	<input type="checkbox"/>	19	40	105	20
OCES4-200S-D	<input type="checkbox"/>	20	40	105	20
OCES4-210S-D	<input type="checkbox"/>	21	50	120	25
OCES4-220S-D	<input type="checkbox"/>	22	50	120	25
OCES4-230S-D	<input type="checkbox"/>	23	50	120	25
OCES4-240S-D	<input type="checkbox"/>	24	50	120	25
OCES4-250S-D	<input type="checkbox"/>	25	50	120	25
OCES4-260S-D	<input type="checkbox"/>	26	50	120	25
OCES4-270S-D	<input type="checkbox"/>	27	50	120	25
OCES4-280S-D	<input type="checkbox"/>	28	60	130	25
OCES4-290S-D	<input type="checkbox"/>	29	60	130	25
OCES4-300S-D	<input type="checkbox"/>	30	60	130	32

71

形番 Cat. No.	在庫 Stock	寸法 (mm) Dimensions (mm)			
		φD	l <sub>1</sub>	L	φd
OCES4-020S-D	<input type="checkbox"/>	2	6	40	4
OCES4-021S-D	<input type="checkbox"/>	2.1	6	40	4
OCES4-022S-D	<input type="checkbox"/>	2.2	6	40	4
OCES4-023S-D	<input type="checkbox"/>	2.3	6	40	4
OCES4-024S-D	<input type="checkbox"/>	2.4	6	40	4
OCES4-025S-D	<input type="checkbox"/>	2.5	8	40	4
OCES4-026S-D	<input type="checkbox"/>	2.6	8	40	4
OCES4-027S-D	<input type="checkbox"/>	2.7	8	40	4
OCES4-028S-D	<input type="checkbox"/>	2.8	8	40	4
OCES4-029S-D	<input type="checkbox"/>	2.9	8	40	4
OCES4-031S-D	<input type="checkbox"/>	3.1	10	45	6
OCES4-032S-D	<input type="checkbox"/>	3.2	10	45	6
OCES4-033S-D	<input type="checkbox"/>	3.3	10	45	6
OCES4-034S-D	<input type="checkbox"/>	3.4	10	45	6
OCES4-036S-D	<input type="checkbox"/>	3.6	11	45	6
OCES4-037S-D	<input type="checkbox"/>	3.7	11	45	6
OCES4-038S-D	<input type="checkbox"/>	3.8	11	45	6
OCES4-039S-D	<input type="checkbox"/>	3.9	11	45	6
OCES4-041S-D	<input type="checkbox"/>	4.1	12	45	6
OCES4-042S-D	<input type="checkbox"/>	4.2	12	45	6
OCES4-043S-D	<input type="checkbox"/>	4.3	12	45	6
OCES4-044S-D	<input type="checkbox"/>	4.4	12	45	6
OCES4-046S-D	<input type="checkbox"/>	4.6	14	45	6
OCES4-047S-D	<input type="checkbox"/>	4.7	14	45	6
OCES4-048S-D	<input type="checkbox"/>	4.8	14	45	6
OCES4-049S-D	<input type="checkbox"/>	4.9	14	45	6
OCES4-051S-D	<input type="checkbox"/>	5.1	15	50	6
OCES4-052S-D	<input type="checkbox"/>	5.2	15	50	6
OCES4-053S-D	<input type="checkbox"/>	5.3	15	50	6
OCES4-054S-D	<input type="checkbox"/>	5.4	15	50	6
OCES4-056S-D	<input type="checkbox"/>	5.6	15	50	6
OCES4-057S-D	<input type="checkbox"/>	5.7	15	50	6
OCES4-058S-D	<input type="checkbox"/>	5.8	15	50	6
OCES4-059S-D	<input type="checkbox"/>	5.9	15	50	6
OCES4-061S-D	<input type="checkbox"/>	6.1	15	50	6
OCES4-062S-D	<input type="checkbox"/>	6.2	15	50	6
OCES4-063S-D	<input type="checkbox"/>	6.3	15	50	6
OCES4-064S-D	<input type="checkbox"/>	6.4	15	50	6
OCES4-066S-D	<input type="checkbox"/>	6.6	15	50	6
OCES4-067S-D	<input type="checkbox"/>	6.7	15	50	6
OCES4-068S-D	<input type="checkbox"/>	6.8	15	50	6

71

## DX-COAT ソリッドワンカットエンドミル OCES4-S-D形

## DX-COAT ソリッドワンカットエンドミル OCES4-L-D形

- 4枚刃ロング刃長、中心刃付き、エキセントリックリリーフ形、ねじれ角30°



(前ページの続き)

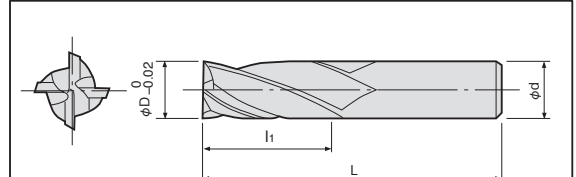
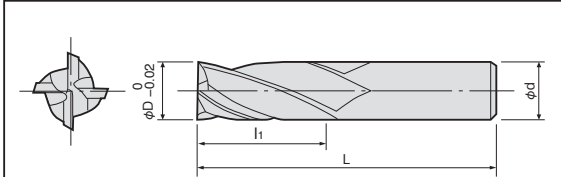

材質: DXコート(TiCN系)

材質: DXコート(TiCN系)

形番 Cat. No.	在庫 Stock	寸法 (mm) Dimensions (mm)			
		$\phi D$	$h_1$	L	$\phi d$
OCES4-069S-D	<input type="checkbox"/>	6.9	15	50	6
OCES4-071S-D	<input type="checkbox"/>	7.1	20	60	8
OCES4-072S-D	<input type="checkbox"/>	7.2	20	60	8
OCES4-073S-D	<input type="checkbox"/>	7.3	20	60	8
OCES4-074S-D	<input type="checkbox"/>	7.4	20	60	8
OCES4-076S-D	<input type="checkbox"/>	7.6	20	60	8
OCES4-077S-D	<input type="checkbox"/>	7.7	20	60	8
OCES4-078S-D	<input type="checkbox"/>	7.8	20	60	8
OCES4-079S-D	<input type="checkbox"/>	7.9	20	60	8
OCES4-081S-D	<input type="checkbox"/>	8.1	20	60	8
OCES4-082S-D	<input type="checkbox"/>	8.2	20	60	8
OCES4-083S-D	<input type="checkbox"/>	8.3	20	60	8
OCES4-084S-D	<input type="checkbox"/>	8.4	20	60	8
OCES4-086S-D	<input type="checkbox"/>	8.6	20	60	8
OCES4-087S-D	<input type="checkbox"/>	8.7	20	60	8
OCES4-088S-D	<input type="checkbox"/>	8.8	20	60	8
OCES4-089S-D	<input type="checkbox"/>	8.9	20	60	8
OCES4-091S-D	<input type="checkbox"/>	9.1	20	65	10
OCES4-092S-D	<input type="checkbox"/>	9.2	20	65	10
OCES4-093S-D	<input type="checkbox"/>	9.3	20	65	10
OCES4-094S-D	<input type="checkbox"/>	9.4	20	65	10
OCES4-096S-D	<input type="checkbox"/>	9.6	20	65	10
OCES4-097S-D	<input type="checkbox"/>	9.7	20	65	10
OCES4-098S-D	<input type="checkbox"/>	9.8	20	65	10
OCES4-099S-D	<input type="checkbox"/>	9.9	20	65	10
OCES4-101S-D	<input type="checkbox"/>	10.1	25	70	10
OCES4-102S-D	<input type="checkbox"/>	10.2	25	70	10
OCES4-103S-D	<input type="checkbox"/>	10.3	25	70	10
OCES4-104S-D	<input type="checkbox"/>	10.4	25	70	10
OCES4-105S-D	<input type="checkbox"/>	10.5	25	70	10
OCES4-106S-D	<input type="checkbox"/>	10.6	25	70	10
OCES4-107S-D	<input type="checkbox"/>	10.7	25	70	10
OCES4-108S-D	<input type="checkbox"/>	10.8	25	70	10
OCES4-109S-D	<input type="checkbox"/>	10.9	25	70	10

形番 Cat. No.	在庫 Stock	寸法 (mm) Dimensions (mm)			
		$\phi D$	$h_1$	L	$\phi d$
OCES4-030L-D	<input type="checkbox"/>	3	20	60	6
OCES4-035L-D	<input type="checkbox"/>	3.5	22	60	6
OCES4-040L-D	<input type="checkbox"/>	4	24	60	6
OCES4-045L-D	<input type="checkbox"/>	4.5	28	60	6
OCES4-050L-D	<input type="checkbox"/>	5	30	70	6
OCES4-055L-D	<input type="checkbox"/>	5.5	30	70	6
OCES4-060L-D	<input type="checkbox"/>	6	30	70	6
OCES4-065L-D	<input type="checkbox"/>	6.5	40	90	8
OCES4-070L-D	<input type="checkbox"/>	7	40	90	8
OCES4-075L-D	<input type="checkbox"/>	7.5	40	90	8
OCES4-080L-D	<input type="checkbox"/>	8	40	90	8
OCES4-085L-D	<input type="checkbox"/>	8.5	40	100	10
OCES4-090L-D	<input type="checkbox"/>	9	40	100	10
OCES4-095L-D	<input type="checkbox"/>	9.5	40	100	10
OCES4-100L-D	<input type="checkbox"/>	10	50	110	10
OCES4-110L-D	<input type="checkbox"/>	11	50	110	12
OCES4-120L-D	<input type="checkbox"/>	12	50	110	12
OCES4-130L-D	<input type="checkbox"/>	13	60	120	12
OCES4-140L-D	<input type="checkbox"/>	14	70	130	16
OCES4-150L-D	<input type="checkbox"/>	15	70	130	16
OCES4-160L-D	<input type="checkbox"/>	16	70	130	16
OCES4-170L-D	<input type="checkbox"/>	17	70	140	20
OCES4-180L-D	<input type="checkbox"/>	18	70	140	20
OCES4-190L-D	<input type="checkbox"/>	19	70	140	20
OCES4-200L-D	<input type="checkbox"/>	20	70	140	20
OCES4-210L-D	<input type="checkbox"/>	21	80	150	25
OCES4-220L-D	<input type="checkbox"/>	22	80	150	25
OCES4-230L-D	<input type="checkbox"/>	23	80	150	25
OCES4-240L-D	<input type="checkbox"/>	24	80	150	25
OCES4-250L-D	<input type="checkbox"/>	25	80	150	25

## ソリッドワンカットエンドミル OCES2-S形

- 2枚刃標準刃長、中心刃付き、エキセントリックリリーフ形、ねじれ角30°



## ソリッドワンカットエンドミル OCES2-L形

- 2枚刃ロング刃長、中心刃付き、エキセントリックリリーフ形、ねじれ角30°

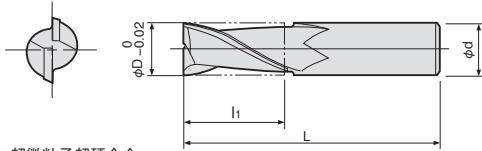

材種: 超微粒子超硬合金

形番 Cat. No.	在庫 Stock	寸法 (mm) Dimensions (mm)			
		φD	l <sub>1</sub>	L	φd
OCES2-010S	<input type="checkbox"/>	1	2.5	40	4
OCES2-015S	<input type="checkbox"/>	1.5	4	40	4
OCES2-020S	<input type="checkbox"/>	2	6	40	4
OCES2-025S	<input type="checkbox"/>	2.5	8	40	4
OCES2-030S	<input type="checkbox"/>	3	10	45	6
OCES2-035S	<input type="checkbox"/>	3.5	11	45	6
OCES2-040S	<input type="checkbox"/>	4	12	45	6
OCES2-045S	<input type="checkbox"/>	4.5	14	45	6
OCES2-050S	<input type="checkbox"/>	5	15	50	6
OCES2-055S	<input type="checkbox"/>	5.5	15	50	6
OCES2-060S	<input type="checkbox"/>	6	15	50	6
OCES2-065S	<input type="checkbox"/>	6.5	15	50	6
OCES2-070S	<input type="checkbox"/>	7	20	60	8
OCES2-075S	<input type="checkbox"/>	7.5	20	60	8
OCES2-080S	<input type="checkbox"/>	8	20	60	8
OCES2-085S	<input type="checkbox"/>	8.5	20	60	8
OCES2-090S	<input type="checkbox"/>	9	20	65	10
OCES2-095S	<input type="checkbox"/>	9.5	20	65	10
OCES2-100S	<input type="checkbox"/>	10	25	70	10
OCES2-105S	<input type="checkbox"/>	10.5	25	70	10
OCES2-110S	<input type="checkbox"/>	11	25	75	12
OCES2-115S	<input type="checkbox"/>	11.5	25	75	12
OCES2-120S	<input type="checkbox"/>	12	25	75	12
OCES2-125S	<input type="checkbox"/>	12.5	30	80	12
OCES2-130S	<input type="checkbox"/>	13	30	80	12
OCES2-135S	<input type="checkbox"/>	13.5	35	90	16
OCES2-140S	<input type="checkbox"/>	14	35	90	16
OCES2-145S	<input type="checkbox"/>	14.5	35	90	16
OCES2-150S	<input type="checkbox"/>	15	35	90	16
OCES2-155S	<input type="checkbox"/>	15.5	35	90	16
OCES2-160S	<input type="checkbox"/>	16	35	90	16
OCES2-165S	<input type="checkbox"/>	16.5	40	105	20
OCES2-170S	<input type="checkbox"/>	17	40	105	20
OCES2-175S	<input type="checkbox"/>	17.5	40	105	20
OCES2-180S	<input type="checkbox"/>	18	40	105	20
OCES2-185S	<input type="checkbox"/>	18.5	40	105	20
OCES2-190S	<input type="checkbox"/>	19	40	105	20
OCES2-195S	<input type="checkbox"/>	19.5	40	105	20
OCES2-200S	<input type="checkbox"/>	20	40	105	20
OCES2-210S	<input type="checkbox"/>	21	50	120	25
OCES2-220S	<input type="checkbox"/>	22	50	120	25
OCES2-230S	<input type="checkbox"/>	23	50	120	25
OCES2-240S	<input type="checkbox"/>	24	50	120	25
OCES2-250S	<input type="checkbox"/>	25	50	120	25
OCES2-260S	<input type="checkbox"/>	26	50	120	25
OCES2-270S	<input type="checkbox"/>	27	50	120	25
OCES2-280S	<input type="checkbox"/>	28	60	130	25
OCES2-290S	<input type="checkbox"/>	29	60	130	32
OCES2-300S	<input type="checkbox"/>	30	60	130	32

751

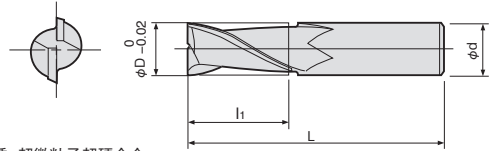

材種: 超微粒子超硬合金

形番 Cat. No.	在庫 Stock	寸法 (mm) Dimensions (mm)			
		φD	l <sub>1</sub>	L	φd
OCES2-030L	<input type="checkbox"/>	3	20	60	6
OCES2-035L	<input type="checkbox"/>	3.5	22	60	6
OCES2-040L	<input type="checkbox"/>	4	24	60	6
OCES2-045L	<input type="checkbox"/>	4.5	28	60	6
OCES2-050L	<input type="checkbox"/>	5	30	70	6
OCES2-055L	<input type="checkbox"/>	5.5	30	70	6
OCES2-060L	<input type="checkbox"/>	6	30	70	6
OCES2-065L	<input type="checkbox"/>	6.5	40	90	8
OCES2-070L	<input type="checkbox"/>	7	40	90	8
OCES2-075L	<input type="checkbox"/>	7.5	40	90	8
OCES2-080L	<input type="checkbox"/>	8	40	90	8
OCES2-085L	<input type="checkbox"/>	8.5	40	100	10
OCES2-090L	<input type="checkbox"/>	9	40	100	10
OCES2-095L	<input type="checkbox"/>	9.5	40	100	10
OCES2-100L	<input type="checkbox"/>	10	50	110	10
OCES2-105L	<input type="checkbox"/>	10.5	50	110	12
OCES2-110L	<input type="checkbox"/>	11	50	110	12
OCES2-115L	<input type="checkbox"/>	11.5	50	110	12
OCES2-120L	<input type="checkbox"/>	12	50	110	12
OCES2-125L	<input type="checkbox"/>	12.5	60	120	12
OCES2-130L	<input type="checkbox"/>	13	60	120	12
OCES2-135L	<input type="checkbox"/>	13.5	70	130	16
OCES2-140L	<input type="checkbox"/>	14	70	130	16
OCES2-145L	<input type="checkbox"/>	14.5	70	130	16
OCES2-150L	<input type="checkbox"/>	15	70	130	16
OCES2-155L	<input type="checkbox"/>	15.5	70	130	16
OCES2-160L	<input type="checkbox"/>	16	70	130	16
OCES2-165L	<input type="checkbox"/>	16.5	70	140	20
OCES2-170L	<input type="checkbox"/>	17	70	140	20
OCES2-175L	<input type="checkbox"/>	17.5	70	140	20
OCES2-180L	<input type="checkbox"/>	18	70	140	20
OCES2-185L	<input type="checkbox"/>	18.5	70	140	20
OCES2-190L	<input type="checkbox"/>	19	70	140	20
OCES2-195L	<input type="checkbox"/>	19.5	70	140	20
OCES2-200L	<input type="checkbox"/>	20	70	140	20
OCES2-210L	<input type="checkbox"/>	21	80	150	25
OCES2-220L	<input type="checkbox"/>	22	80	150	25
OCES2-230L	<input type="checkbox"/>	23	80	150	25
OCES2-240L	<input type="checkbox"/>	24	80	150	25
OCES2-250L	<input type="checkbox"/>	25	80	150	25

151



## ソリッドワンカットエンドミル OCES4-S形

- 4枚刃標準刃長、中心刃付き、エキセントリックリリーフ形、ねじれ角30°

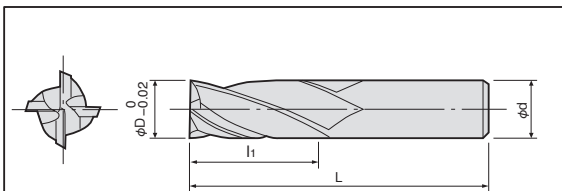

材種: 超微粒子超硬合金

形番 Cat. No.	在庫 Stock	寸法 (mm) Dimensions (mm)			
		φD	l <sub>1</sub>	L	φd
OCES4-030S	<input type="checkbox"/>	3	10	45	6
OCES4-035S	<input type="checkbox"/>	3.5	11	45	6
OCES4-040S	<input type="checkbox"/>	4	12	45	6
OCES4-045S	<input type="checkbox"/>	4.5	14	45	6
OCES4-050S	<input type="checkbox"/>	5	15	50	6
OCES4-055S	<input type="checkbox"/>	5.5	15	50	6
OCES4-060S	<input type="checkbox"/>	6	15	50	6
OCES4-065S	<input type="checkbox"/>	6.5	15	50	6
OCES4-070S	<input type="checkbox"/>	7	20	60	8
OCES4-075S	<input type="checkbox"/>	7.5	20	60	8
OCES4-080S	<input type="checkbox"/>	8	20	60	8
OCES4-085S	<input type="checkbox"/>	8.5	20	60	8
OCES4-090S	<input type="checkbox"/>	9	20	65	10
OCES4-095S	<input type="checkbox"/>	9.5	20	65	10
OCES4-100S	<input type="checkbox"/>	10	25	70	10
OCES4-105S	<input type="checkbox"/>	10.5	25	70	10
OCES4-110S	<input type="checkbox"/>	11	25	75	12
OCES4-115S	<input type="checkbox"/>	11.5	25	75	12
OCES4-120S	<input type="checkbox"/>	12	25	75	12
OCES4-125S	<input type="checkbox"/>	12.5	30	80	12
OCES4-130S	<input type="checkbox"/>	13	30	80	12
OCES4-135S	<input type="checkbox"/>	13.5	35	90	16
OCES4-140S	<input type="checkbox"/>	14	35	90	16
OCES4-145S	<input type="checkbox"/>	14.5	35	90	16
OCES4-150S	<input type="checkbox"/>	15	35	90	16
OCES4-155S	<input type="checkbox"/>	15.5	35	90	16
OCES4-160S	<input type="checkbox"/>	16	35	90	16
OCES4-165S	<input type="checkbox"/>	16.5	40	105	20
OCES4-170S	<input type="checkbox"/>	17	40	105	20
OCES4-175S	<input type="checkbox"/>	17.5	40	105	20
OCES4-180S	<input type="checkbox"/>	18	40	105	20
OCES4-185S	<input type="checkbox"/>	18.5	40	105	20
OCES4-190S	<input type="checkbox"/>	19	40	105	20
OCES4-195S	<input type="checkbox"/>	19.5	40	105	20
OCES4-200S	<input type="checkbox"/>	20	40	105	20
OCES4-210S	<input type="checkbox"/>	21	50	120	25
OCES4-220S	<input type="checkbox"/>	22	50	120	25
OCES4-230S	<input type="checkbox"/>	23	50	120	25
OCES4-240S	<input type="checkbox"/>	24	50	120	25
OCES4-250S	<input type="checkbox"/>	25	50	120	25
OCES4-260S	<input type="checkbox"/>	26	50	120	25
OCES4-270S	<input type="checkbox"/>	27	50	120	25
OCES4-280S	<input type="checkbox"/>	28	60	130	25
OCES4-290S	<input type="checkbox"/>	29	60	130	32
OCES4-300S	<input type="checkbox"/>	30	60	130	32

451

## ソリッドワンカットエンドミル OCES4-L形

- 4枚刃ロング刃長、中心刃付き、エキセントリックリリーフ形、ねじれ角30°

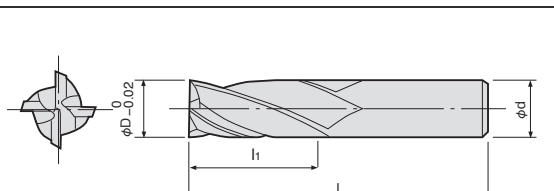

材種: 超微粒子超硬合金

形番 Cat. No.	在庫 Stock	寸法 (mm) Dimensions (mm)			
		φD	l <sub>1</sub>	L	φd
OCES4-030L	<input type="checkbox"/>	3	20	60	6
OCES4-035L	<input type="checkbox"/>	3.5	22	60	6
OCES4-040L	<input type="checkbox"/>	4	24	60	6
OCES4-045L	<input type="checkbox"/>	4.5	28	60	6
OCES4-050L	<input type="checkbox"/>	5	30	70	6
OCES4-055L	<input type="checkbox"/>	5.5	30	70	6
OCES4-060L	<input type="checkbox"/>	6	30	70	6
OCES4-065L	<input type="checkbox"/>	6.5	40	90	8
OCES4-070L	<input type="checkbox"/>	7	40	90	8
OCES4-075L	<input type="checkbox"/>	7.5	40	90	8
OCES4-080L	<input type="checkbox"/>	8	40	90	8
OCES4-085L	<input type="checkbox"/>	8.5	40	100	10
OCES4-090L	<input type="checkbox"/>	9	40	100	10
OCES4-095L	<input type="checkbox"/>	9.5	40	100	10
OCES4-100L	<input type="checkbox"/>	10	50	110	10
OCES4-105L	<input type="checkbox"/>	10.5	50	110	12
OCES4-110L	<input type="checkbox"/>	11	50	110	12
OCES4-115L	<input type="checkbox"/>	11.5	50	110	12
OCES4-120L	<input type="checkbox"/>	12	50	110	12
OCES4-125L	<input type="checkbox"/>	12.5	60	120	12
OCES4-130L	<input type="checkbox"/>	13	60	120	12
OCES4-135L	<input type="checkbox"/>	13.5	70	130	16
OCES4-140L	<input type="checkbox"/>	14	70	130	16
OCES4-145L	<input type="checkbox"/>	14.5	70	130	16
OCES4-150L	<input type="checkbox"/>	15	70	130	16
OCES4-155L	<input type="checkbox"/>	15.5	70	130	16
OCES4-160L	<input type="checkbox"/>	16	70	130	16
OCES4-165L	<input type="checkbox"/>	16.5	70	140	20
OCES4-170L	<input type="checkbox"/>	17	70	140	20
OCES4-175L	<input type="checkbox"/>	17.5	70	140	20
OCES4-180L	<input type="checkbox"/>	18	70	140	20
OCES4-185L	<input type="checkbox"/>	18.5	70	140	20
OCES4-190L	<input type="checkbox"/>	19	70	140	20
OCES4-195L	<input type="checkbox"/>	19.5	70	140	20
OCES4-200L	<input type="checkbox"/>	20	70	140	20
OCES4-210L	<input type="checkbox"/>	21	80	150	25
OCES4-220L	<input type="checkbox"/>	22	80	150	25
OCES4-230L	<input type="checkbox"/>	23	80	150	25
OCES4-240L	<input type="checkbox"/>	24	80	150	25
OCES4-250L	<input type="checkbox"/>	25	80	150	25

751



# アルミ加工用ソリッドエンドミル

# OCAS2-S形

●2枚刃、ねじれ角30°、45°(※)

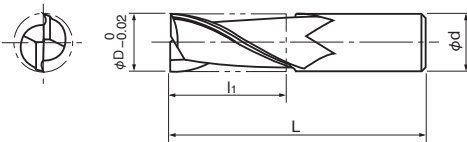

形番 Cat. No.	在庫 Stock	寸法 (mm) Dimensions (mm)			
		φD	Li	L	φd
※OCAS2-010S45	<input type="checkbox"/>	1.0	2.8	40	4
※OCAS2-011S45	<input type="checkbox"/>	1.1	2.8	40	4
※OCAS2-012S45	<input type="checkbox"/>	1.2	2.8	40	4
※OCAS2-013S45	<input type="checkbox"/>	1.3	2.8	40	4
※OCAS2-014S45	<input type="checkbox"/>	1.4	2.8	40	4
※OCAS2-015S45	<input type="checkbox"/>	1.5	4.4	40	4
※OCAS2-016S45	<input type="checkbox"/>	1.6	4.4	40	4
※OCAS2-017S45	<input type="checkbox"/>	1.7	4.4	40	4
※OCAS2-018S45	<input type="checkbox"/>	1.8	4.4	40	4
※OCAS2-019S45	<input type="checkbox"/>	1.9	4.4	40	4
※OCAS2-020S45	<input type="checkbox"/>	2.0	7.0	40	4
※OCAS2-021S45	<input type="checkbox"/>	2.1	7.0	40	4
※OCAS2-022S45	<input type="checkbox"/>	2.2	7.0	40	4
※OCAS2-023S45	<input type="checkbox"/>	2.3	7.0	40	4
※OCAS2-024S45	<input type="checkbox"/>	2.4	7.0	40	4
※OCAS2-025S45	<input type="checkbox"/>	2.5	9.0	40	4
※OCAS2-026S45	<input type="checkbox"/>	2.6	9.0	40	4
※OCAS2-027S45	<input type="checkbox"/>	2.7	9.0	40	4
※OCAS2-028S45	<input type="checkbox"/>	2.8	9.0	40	4
※OCAS2-029S45	<input type="checkbox"/>	2.9	9.0	40	4
OCAS2-030S	<input type="checkbox"/>	3.0	11.0	50	6
OCAS2-031S	<input type="checkbox"/>	3.1	11.0	50	6
OCAS2-032S	<input type="checkbox"/>	3.2	11.0	50	6
OCAS2-033S	<input type="checkbox"/>	3.3	11.0	50	6
OCAS2-034S	<input type="checkbox"/>	3.4	11.0	50	6
OCAS2-035S	<input type="checkbox"/>	3.5	12.0	50	6
OCAS2-036S	<input type="checkbox"/>	3.6	12.0	50	6
OCAS2-037S	<input type="checkbox"/>	3.7	12.0	50	6
OCAS2-038S	<input type="checkbox"/>	3.8	12.0	50	6
OCAS2-039S	<input type="checkbox"/>	3.9	12.0	50	6
OCAS2-040S	<input type="checkbox"/>	4.0	14.0	50	6
OCAS2-041S	<input type="checkbox"/>	4.1	14.0	50	6
OCAS2-042S	<input type="checkbox"/>	4.2	14.0	50	6
OCAS2-043S	<input type="checkbox"/>	4.3	14.0	50	6
OCAS2-044S	<input type="checkbox"/>	4.4	14.0	50	6
OCAS2-045S	<input type="checkbox"/>	4.5	16.0	50	6
OCAS2-046S	<input type="checkbox"/>	4.6	16.0	50	6
OCAS2-047S	<input type="checkbox"/>	4.7	16.0	50	6
OCAS2-048S	<input type="checkbox"/>	4.8	16.0	50	6
OCAS2-049S	<input type="checkbox"/>	4.9	16.0	50	6
OCAS2-050S	<input type="checkbox"/>	5.0	17.0	55	6
OCAS2-051S	<input type="checkbox"/>	5.1	17.0	55	6
OCAS2-052S	<input type="checkbox"/>	5.2	17.0	55	6

形番 Cat. No.	在庫 Stock	寸法 (mm) Dimensions (mm)			
		φD	Li	L	φd
OCAS2-053S	<input type="checkbox"/>	5.3	17.0	55	6
OCAS2-054S	<input type="checkbox"/>	5.4	17.0	55	6
OCAS2-055S	<input type="checkbox"/>	5.5	17.0	55	6
OCAS2-056S	<input type="checkbox"/>	5.6	17.0	55	6
OCAS2-057S	<input type="checkbox"/>	5.7	17.0	55	6
OCAS2-058S	<input type="checkbox"/>	5.8	17.0	55	6
OCAS2-059S	<input type="checkbox"/>	5.9	17.0	55	6
OCAS2-060S	<input type="checkbox"/>	6.0	17.0	55	6
OCAS2-061S	<input type="checkbox"/>	6.1	17.0	55	6
OCAS2-062S	<input type="checkbox"/>	6.2	17.0	55	6
OCAS2-063S	<input type="checkbox"/>	6.3	17.0	55	6
OCAS2-064S	<input type="checkbox"/>	6.4	17.0	55	6
OCAS2-065S	<input type="checkbox"/>	6.5	17.0	55	6
OCAS2-066S	<input type="checkbox"/>	6.6	17.0	55	6
OCAS2-067S	<input type="checkbox"/>	6.7	17.0	55	6
OCAS2-068S	<input type="checkbox"/>	6.8	17.0	55	6
OCAS2-069S	<input type="checkbox"/>	6.9	17.0	55	6
OCAS2-070S	<input type="checkbox"/>	7.0	22.0	65	8
OCAS2-071S	<input type="checkbox"/>	7.1	22.0	65	8
OCAS2-072S	<input type="checkbox"/>	7.2	22.0	65	8
OCAS2-073S	<input type="checkbox"/>	7.3	22.0	65	8
OCAS2-074S	<input type="checkbox"/>	7.4	22.0	65	8
OCAS2-075S	<input type="checkbox"/>	7.5	22.0	65	8
OCAS2-076S	<input type="checkbox"/>	7.6	22.0	65	8
OCAS2-077S	<input type="checkbox"/>	7.7	22.0	65	8
OCAS2-078S	<input type="checkbox"/>	7.8	22.0	65	8
OCAS2-079S	<input type="checkbox"/>	7.9	22.0	65	8
OCAS2-080S	<input type="checkbox"/>	8.0	22.0	65	8
OCAS2-081S	<input type="checkbox"/>	8.1	22.0	65	8
OCAS2-082S	<input type="checkbox"/>	8.2	22.0	65	8
OCAS2-083S	<input type="checkbox"/>	8.3	22.0	65	8
OCAS2-084S	<input type="checkbox"/>	8.4	22.0	65	8
OCAS2-085S	<input type="checkbox"/>	8.5	22.0	65	8
OCAS2-086S	<input type="checkbox"/>	8.6	22.0	65	8
OCAS2-087S	<input type="checkbox"/>	8.7	22.0	65	8
OCAS2-088S	<input type="checkbox"/>	8.8	22.0	65	8
OCAS2-089S	<input type="checkbox"/>	8.9	22.0	65	8
OCAS2-090S	<input type="checkbox"/>	9.0	22.0	70	10
OCAS2-091S	<input type="checkbox"/>	9.1	22.0	70	10
OCAS2-092S	<input type="checkbox"/>	9.2	22.0	70	10
OCAS2-093S	<input type="checkbox"/>	9.3	22.0	70	10
OCAS2-094S	<input type="checkbox"/>	9.4	22.0	70	10
OCAS2-095S	<input type="checkbox"/>	9.5	22.0	70	10

形番 Cat. No.	在庫 Stock	寸法 (mm) Dimensions (mm)			
		φD	Li	L	φd
OCAS2-096S	<input type="checkbox"/>	9.6	22.0	70	10
OCAS2-097S	<input type="checkbox"/>	9.7	22.0	70	10
OCAS2-098S	<input type="checkbox"/>	9.8	22.0	70	10
OCAS2-099S	<input type="checkbox"/>	9.9	22.0	70	10
OCAS2-100S	<input type="checkbox"/>	10.0	28.0	75	10
OCAS2-105S	<input type="checkbox"/>	10.5	28.0	75	10
OCAS2-110S	<input type="checkbox"/>	11.0	28.0	80	12
OCAS2-115S	<input type="checkbox"/>	11.5	28.0	80	12
OCAS2-120S	<input type="checkbox"/>	12.0	28.0	80	12
OCAS2-130S	<input type="checkbox"/>	13.0	35.0	85	12
OCAS2-140S	<input type="checkbox"/>	14.0	40.0	95	16
OCAS2-150S	<input type="checkbox"/>	15.0	40.0	95	16
OCAS2-160S	<input type="checkbox"/>	16.0	40.0	95	16
OCAS2-170S	<input type="checkbox"/>	17.0	45.0	115	20
OCAS2-180S	<input type="checkbox"/>	18.0	45.0	115	20
OCAS2-190S	<input type="checkbox"/>	19.0	45.0	115	20
OCAS2-200S	<input type="checkbox"/>	20.0	45.0	115	20
OCAS2-210S	<input type="checkbox"/>	21.0	55.0	130	25
OCAS2-220S	<input type="checkbox"/>	22.0	55.0	130	25
OCAS2-230S	<input type="checkbox"/>	23.0	55.0	130	25
OCAS2-240S	<input type="checkbox"/>	24.0	55.0	130	25
OCAS2-250S	<input type="checkbox"/>	25.0	55.0	130	25
OCAS2-260S	<input type="checkbox"/>	26.0	55.0	130	32
OCAS2-270S	<input type="checkbox"/>	27.0	55.0	130	32
OCAS2-280S	<input type="checkbox"/>	28.0	65.0	140	32
OCAS2-290S	<input type="checkbox"/>	29.0	65.0	140	32
OCAS2-300S	<input type="checkbox"/>	30.0	65.0	140	32



## アルミ加工用 ソリッドエンドミル OCAS2-L形

●2枚刃、ねじれ角30°



## アルミ加工用 ソリッドエンドミル OCAS2-L45形

●2枚刃、ねじれ角45°

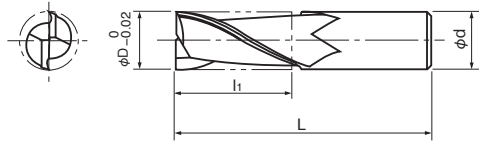
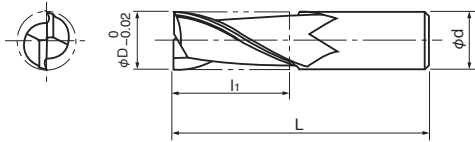

形番 Cat. No.	在庫 Stock	寸法 (mm) Dimensions (mm)			
		φD	l <sub>1</sub>	L	φd
OCAS2-030L	<input type="checkbox"/>	3	22	65	6
OCAS2-035L	<input type="checkbox"/>	3.5	24	65	6
OCAS2-040L	<input type="checkbox"/>	4	26	65	6
OCAS2-045L	<input type="checkbox"/>	4.5	30	65	6
OCAS2-050L	<input type="checkbox"/>	5	32	75	6
OCAS2-055L	<input type="checkbox"/>	5.5	32	75	6
OCAS2-060L	<input type="checkbox"/>	6	32	75	6
OCAS2-065L	<input type="checkbox"/>	6.5	42	95	8
OCAS2-070L	<input type="checkbox"/>	7	42	95	8
OCAS2-075L	<input type="checkbox"/>	7.5	42	95	8
OCAS2-080L	<input type="checkbox"/>	8	42	95	8
OCAS2-085L	<input type="checkbox"/>	8.5	42	110	10
OCAS2-090L	<input type="checkbox"/>	9	42	110	10
OCAS2-095L	<input type="checkbox"/>	9.5	42	110	10
OCAS2-100L	<input type="checkbox"/>	10	53	120	10
OCAS2-105L	<input type="checkbox"/>	10.5	53	120	12
OCAS2-110L	<input type="checkbox"/>	11	53	120	12
OCAS2-115L	<input type="checkbox"/>	11.5	53	120	12
OCAS2-120L	<input type="checkbox"/>	12	53	120	12
OCAS2-130L	<input type="checkbox"/>	13	65	130	12
OCAS2-140L	<input type="checkbox"/>	14	75	140	16
OCAS2-150L	<input type="checkbox"/>	15	75	140	16
OCAS2-160L	<input type="checkbox"/>	16	75	140	16
OCAS2-170L	<input type="checkbox"/>	17	75	150	20
OCAS2-180L	<input type="checkbox"/>	18	75	150	20
OCAS2-190L	<input type="checkbox"/>	19	75	150	20
OCAS2-200L	<input type="checkbox"/>	20	75	150	20
OCAS2-220L	<input type="checkbox"/>	22	85	160	25
OCAS2-250L	<input type="checkbox"/>	25	85	160	25

形番 Cat. No.	在庫 Stock	寸法 (mm) Dimensions (mm)			
		φD	l <sub>1</sub>	L	φd
OCAS2-030L45	<input type="checkbox"/>	3	22	65	6
OCAS2-035L45	<input type="checkbox"/>	3.5	24	65	6
OCAS2-040L45	<input type="checkbox"/>	4	26	65	6
OCAS2-045L45	<input type="checkbox"/>	4.5	30	65	6
OCAS2-050L45	<input type="checkbox"/>	5	32	75	6
OCAS2-055L45	<input type="checkbox"/>	5.5	32	75	6
OCAS2-060L45	<input type="checkbox"/>	6	32	75	6
OCAS2-065L45	<input type="checkbox"/>	6.5	42	95	8
OCAS2-070L45	<input type="checkbox"/>	7	42	95	8
OCAS2-075L45	<input type="checkbox"/>	7.5	42	95	8
OCAS2-080L45	<input type="checkbox"/>	8	42	95	8
OCAS2-085L45	<input type="checkbox"/>	8.5	42	110	10
OCAS2-090L45	<input type="checkbox"/>	9	42	110	10
OCAS2-095L45	<input type="checkbox"/>	9.5	42	110	10
OCAS2-100L45	<input type="checkbox"/>	10	53	120	10
OCAS2-105L45	<input type="checkbox"/>	10.5	53	120	12
OCAS2-110L45	<input type="checkbox"/>	11	53	120	12
OCAS2-115L45	<input type="checkbox"/>	11.5	53	120	12
OCAS2-120L45	<input type="checkbox"/>	12	53	120	12
OCAS2-130L45	<input type="checkbox"/>	13	65	130	12
OCAS2-140L45	<input type="checkbox"/>	14	75	140	16
OCAS2-150L45	<input type="checkbox"/>	15	75	140	16
OCAS2-160L45	<input type="checkbox"/>	16	75	140	16
OCAS2-170L45	<input type="checkbox"/>	17	75	150	20
OCAS2-180L45	<input type="checkbox"/>	18	75	150	20
OCAS2-190L45	<input type="checkbox"/>	19	75	150	20
OCAS2-200L45	<input type="checkbox"/>	20	75	150	20
OCAS2-220L45	<input type="checkbox"/>	22	85	160	25
OCAS2-250L45	<input type="checkbox"/>	25	85	160	25

**ソリッドエンドミル OCKS-P形**

●2枚刃・キー溝加工用、刃径プラス公差  
ねじれ角30°



**DX-COAT ソリッドエンドミル OCKS-P-D形**

●2枚刃・キー溝加工用、刃径プラス公差  
ねじれ角30°

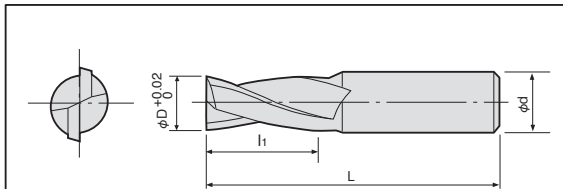

材種: 超微粒子超硬合金

形番 Cat. No.	在庫 Stock	寸法 (mm) Dimensions (mm)			
		φD	l <sub>1</sub>	L	φd
OCKS-020P	●	2	3	50	6
OCKS-030P	●	3	4.5	50	6
OCKS-040P	●	4	6	55	8
OCKS-050P	●	5	7.5	55	8
OCKS-060P	●	6	9	55	8
OCKS-070P	□	7	10.5	60	10
OCKS-080P	□	8	12	60	10
OCKS-090P	□	9	13.5	65	12
OCKS-100P	□	10	15	65	12
OCKS-110P	□	11	16.5	65	12
OCKS-120P	□	12	18	65	12
OCKS-130P	□	13	19.5	70	16

51

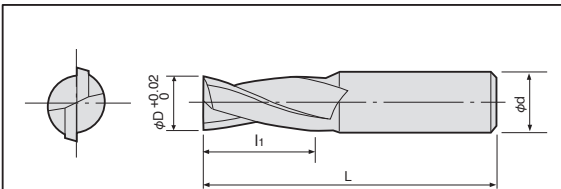

材種: DXコート(TiCN系)

形番 Cat. No.	在庫 Stock	寸法 (mm) Dimensions (mm)			
		φD	l <sub>1</sub>	L	φd
OCKS-020P-D	□	2	3	50	6
OCKS-030P-D	□	3	4.5	50	6
OCKS-040P-D	□	4	6	55	8
OCKS-050P-D	□	5	7.5	55	8
OCKS-060P-D	□	6	9	55	8
OCKS-070P-D	□	7	10.5	60	10
OCKS-080P-D	□	8	12	60	10
OCKS-090P-D	□	9	13.5	65	12
OCKS-100P-D	□	10	15	65	12
OCKS-110P-D	□	11	16.5	65	12
OCKS-120P-D	□	12	18	65	12
OCKS-130P-D	□	13	19.5	70	16

61

流通在庫品



## ソリッドエンドミル

## DYK5形

●2枚刃、スクエアエンドミル

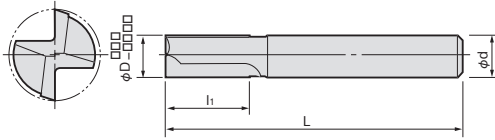

材種: 超微粒子超硬合金

形番	在庫	寸法 (mm)			
		φD	l <sub>1</sub>	L	φd
DYK5-020	<input type="checkbox"/>	2	20	65	6
DYK5-030	<input type="checkbox"/>	3	20	75	6
DYK5-040	<input type="checkbox"/>	4	20	75	6
DYK5-050	<input type="checkbox"/>	5	25	75	6
DYK5-060	<input type="checkbox"/>	6	25	80	6
DYK5-070	<input type="checkbox"/>	7	25	80	6
DYK5-080	<input type="checkbox"/>	8	25	80	8
DYK5-090	<input type="checkbox"/>	9	30	80	8
DYK5-100	<input type="checkbox"/>	10	30	90	10
DYK5-110	<input type="checkbox"/>	11	30	110	12
DYK5-120	<input type="checkbox"/>	12	30	110	12
DYK5-130	<input type="checkbox"/>	13	35	110	12
DYK5-140	<input type="checkbox"/>	14	35	110	12
DYK5-150	<input type="checkbox"/>	15	35	110	12
DYK5-160	<input type="checkbox"/>	16	35	120	16
DYK5-170	<input type="checkbox"/>	17	40	120	16
DYK5-180	<input type="checkbox"/>	18	40	120	16
DYK5-190	<input type="checkbox"/>	19	40	140	20
DYK5-200	<input type="checkbox"/>	20	40	140	20

## ソリッドエンドミル

## SCSE形

●2枚刃、スクエアエンドミル

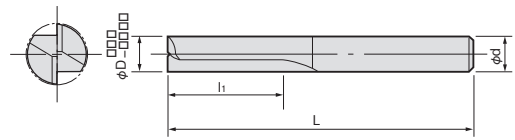

材種: 超微粒子超硬合金

形番	在庫	寸法 (mm)			
		φD	l <sub>1</sub>	L	φd
SCSE-2010	<input type="checkbox"/>	1	5	40	3
SCSE-2015	<input type="checkbox"/>	1.5	7	40	3
SCSE-2020	<input type="checkbox"/>	2	10	40	3
SCSE-2025	<input type="checkbox"/>	2.5	15	45	3
SCSE-2030	<input type="checkbox"/>	3	15	45	3
SCSE-2040	<input type="checkbox"/>	4	20	45	4
SCSE-2050	<input type="checkbox"/>	5	25	60	6
SCSE-2060	<input type="checkbox"/>	6	25	60	6
SCSE-2080	<input type="checkbox"/>	8	25	80	8
SCSE-2100	<input type="checkbox"/>	10	30	80	10
SCSE-2120	<input type="checkbox"/>	12	30	80	12

## ソリッドエンドミル

## SCEL形

●2枚刃、ねじれ角30°、ミニチュアタイプ



## ソリッド エクストラロングエンドミル

## EXL-E2形

●2枚刃、ねじれ角30°

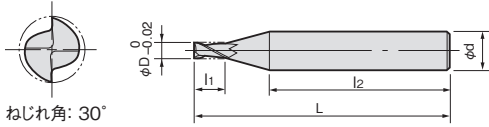

ねじれ角: 30°

材種: 超微粒子超硬合金

形番 Cat. No.	在庫 Stock	寸法 (mm) Dimensions (mm)				
		φD	l <sub>1</sub>	l <sub>2</sub>	L	φd
SCEL-2002	<input type="checkbox"/>	0.2	1.2	29.9	40	3
SCEL-2003	<input type="checkbox"/>	0.3	1.8	29.5	40	3
SCEL-2004	<input type="checkbox"/>	0.4	2.4	29.2	40	3
SCEL-2005	<input type="checkbox"/>	0.5	3	28.9	40	3
SCEL-2006	<input type="checkbox"/>	0.6	3.6	28.6	40	3
SCEL-2007	<input type="checkbox"/>	0.7	4.2	28.3	40	3
SCEL-2008	<input type="checkbox"/>	0.8	4.8	28	40	3
SCEL-2009	<input type="checkbox"/>	0.9	5.4	27.6	40	3
SCEL-2010	<input type="checkbox"/>	1	6	24.5	40	4
SCEL-2011	<input type="checkbox"/>	1.1	6.6	24.2	40	4
SCEL-2012	<input type="checkbox"/>	1.2	7.2	23.9	40	4
SCEL-2013	<input type="checkbox"/>	1.3	7.8	23.5	40	4
SCEL-2014	<input type="checkbox"/>	1.4	8.4	23.2	40	4
SCEL-2015	<input type="checkbox"/>	1.5	9	22.9	40	4
SCEL-2016	<input type="checkbox"/>	1.6	10	22.2	40	4
SCEL-2017	<input type="checkbox"/>	1.7	10	22.5	40	4
SCEL-2018	<input type="checkbox"/>	1.8	10	22.8	40	4
SCEL-2019	<input type="checkbox"/>	1.9	11	22	40	4
SCEL-2020	<input type="checkbox"/>	2	12	21.3	40	4
SCEL-2021	<input type="checkbox"/>	2.1	12	26.6	45	4
SCEL-2022	<input type="checkbox"/>	2.2	13	25.9	45	4
SCEL-2023	<input type="checkbox"/>	2.3	13	26.2	45	4
SCEL-2024	<input type="checkbox"/>	2.4	14	25.5	45	4
SCEL-2025	<input type="checkbox"/>	2.5	15	29.7	50	4
SCEL-2026	<input type="checkbox"/>	2.6	15	30	50	4
SCEL-2027	<input type="checkbox"/>	2.7	17	28.3	50	4
SCEL-2028	<input type="checkbox"/>	2.8	17	28.9	50	4
SCEL-2029	<input type="checkbox"/>	2.9	17	28.9	50	4

41

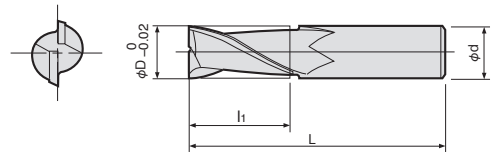

材種: 超微粒子超硬合金

形番 Cat. No.	在庫 Stock	寸法 (mm) Dimensions (mm)			
		φD	l <sub>1</sub>	L	φd
EXL-E2-10X 60	<input type="checkbox"/>	10	60	110	10
EXL-E2-10X 80	<input type="checkbox"/>	10	80	130	10
EXL-E2-10X100	<input type="checkbox"/>	10	100	150	10
EXL-E2-12X 80	<input type="checkbox"/>	12	80	130	12
EXL-E2-12X100	<input type="checkbox"/>	12	100	150	12
EXL-E2-12X120	<input type="checkbox"/>	12	120	170	12
EXL-E2-13X100	<input type="checkbox"/>	13	100	150	12
EXL-E2-14X 80	<input type="checkbox"/>	14	80	140	16
EXL-E2-14X100	<input type="checkbox"/>	14	100	160	16
EXL-E2-14X120	<input type="checkbox"/>	14	120	180	16
EXL-E2-15X 80	<input type="checkbox"/>	15	80	140	16
EXL-E2-15X100	<input type="checkbox"/>	15	100	160	16
EXL-E2-15X120	<input type="checkbox"/>	15	120	180	16
EXL-E2-15X150	<input type="checkbox"/>	15	150	210	16
EXL-E2-16X100	<input type="checkbox"/>	16	100	160	16
EXL-E2-16X150	<input type="checkbox"/>	16	150	210	16
EXL-E2-17X100	<input type="checkbox"/>	17	100	160	20
EXL-E2-18X100	<input type="checkbox"/>	18	100	160	20
EXL-E2-18X150	<input type="checkbox"/>	18	150	210	20
EXL-E2-19X100	<input type="checkbox"/>	19	100	160	20
EXL-E2-20X100	<input type="checkbox"/>	20	100	160	20
EXL-E2-20X120	<input type="checkbox"/>	20	120	180	20
EXL-E2-20X150	<input type="checkbox"/>	20	150	210	20
EXL-E2-22X100	<input type="checkbox"/>	22	100	160	20
EXL-E2-25X100	<input type="checkbox"/>	25	100	180	25
EXL-E2-30X100	<input type="checkbox"/>	30	100	180	25

95

## ソリッド エクストラロングエンドミル EXL-E4形

●4枚刃、ねじれ角30°

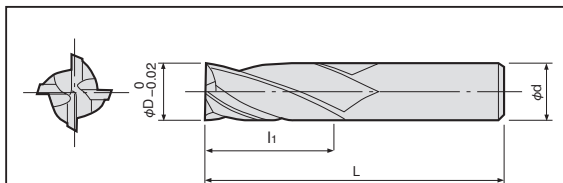

材種：超微粒子超硬合金

形番 Cat. No.	在庫 Stock	寸法 (mm) Dimensions (mm)			
		φD	l <sub>1</sub>	L	φd
EXL-E4-10X60	<input type="checkbox"/>	10	60	110	10
EXL-E4-10X80	<input type="checkbox"/>	10	80	130	10
EXL-E4-10X100	<input type="checkbox"/>	10	100	150	10
EXL-E4-12X80	<input type="checkbox"/>	12	80	130	12
EXL-E4-12X100	<input type="checkbox"/>	12	100	150	12
EXL-E4-12X120	<input type="checkbox"/>	12	120	170	12
EXL-E4-13X100	<input type="checkbox"/>	13	100	150	12
EXL-E4-14X80	<input type="checkbox"/>	14	80	140	16
EXL-E4-14X100	<input type="checkbox"/>	14	100	160	16
EXL-E4-14X120	<input type="checkbox"/>	14	120	180	16
EXL-E4-15X80	<input type="checkbox"/>	15	80	140	16
EXL-E4-15X100	<input type="checkbox"/>	15	100	160	16
EXL-E4-15X120	<input type="checkbox"/>	15	120	180	16
EXL-E4-15X150	<input type="checkbox"/>	15	150	210	16
EXL-E4-16X100	<input type="checkbox"/>	16	100	160	16
EXL-E4-16X150	<input type="checkbox"/>	16	150	210	16
EXL-E4-17X100	<input type="checkbox"/>	17	100	160	20
EXL-E4-18X100	<input type="checkbox"/>	18	100	160	20
EXL-E4-18X150	<input type="checkbox"/>	18	150	210	20
EXL-E4-19X100	<input type="checkbox"/>	19	100	160	20
EXL-E4-20X100	<input type="checkbox"/>	20	100	160	20
EXL-E4-20X120	<input type="checkbox"/>	20	120	180	20
EXL-E4-20X150	<input type="checkbox"/>	20	150	210	20
EXL-E4-22X100	<input type="checkbox"/>	22	100	160	20
EXL-E4-25X100	<input type="checkbox"/>	25	100	180	25
EXL-E4-30X100	<input type="checkbox"/>	30	100	180	25

35

## ソリッドエンドミル LS-OCFS2形

●2枚刃、ロングシャンク

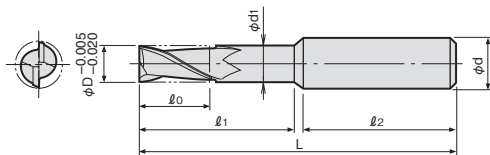

材種：超微粒子超硬合金

形番 Cat. No.	在庫 Stock	寸法 (mm) Dimensions (mm)						
		φD	l <sub>0</sub>	l <sub>1</sub>	l <sub>2</sub>	L	φd <sub>1</sub>	φd
LS-OCFS2-020	<input type="checkbox"/>	2	10	40	96	140	2	4
LS-OCFS2-025	<input type="checkbox"/>	2.5	15	40	97	140	2.5	4
LS-OCFS2-030	<input type="checkbox"/>	3	15	40	98	140	3	4
LS-OCFS2-035	<input type="checkbox"/>	3.5	20	40	99	140	3.5	4
LS-OCFS2-040	<input type="checkbox"/>	4	20	40	96	140	3.95	6
LS-OCFS2-045	<input type="checkbox"/>	4.5	28	50	97	150	4.45	6
LS-OCFS2-050	<input type="checkbox"/>	5	28	50	98	150	4.95	6
LS-OCFS2-055	<input type="checkbox"/>	5.5	30	50	99	150	5.45	6
LS-OCFS2-060	<input type="checkbox"/>	6	30	50	100	150	5.95	6
LS-OCFS2-065	<input type="checkbox"/>	6.5	30	50	100	150	6.45	6
LS-OCFS2-070	<input type="checkbox"/>	7	40	80	97	180	6.9	8
LS-OCFS2-075	<input type="checkbox"/>	7.5	40	80	98	180	7.4	8
LS-OCFS2-080	<input type="checkbox"/>	8	40	80	100	180	7.9	8
LS-OCFS2-085	<input type="checkbox"/>	8.5	40	80	100	180	8.4	8
LS-OCFS2-090	<input type="checkbox"/>	9	50	125	102	230	8.9	10
LS-OCFS2-100	<input type="checkbox"/>	10	50	125	105	230	9.9	10
LS-OCFS2-110	<input type="checkbox"/>	11	50	125	102	230	10.9	12
LS-OCFS2-120	<input type="checkbox"/>	12	50	125	105	230	11.9	12
LS-OCFS2-140	<input type="checkbox"/>	14	70	125	121	250	13.9	16
LS-OCFS2-150	<input type="checkbox"/>	15	70	125	122	250	14.9	16
LS-OCFS2-160	<input type="checkbox"/>	16	70	125	125	250	15.9	16
LS-OCFS2-180	<input type="checkbox"/>	18	70	125	121	250	17.9	20
LS-OCFS2-200	<input type="checkbox"/>	20	70	125	125	250	19.9	20
LS-OCFS2-250	<input type="checkbox"/>	25	70	125	125	250	24.9	25
LS-OCFS2-300	<input type="checkbox"/>	30	80	125	121	250	29.9	32

441

## ソリッドエンドミル LS-OCFS4形

●4枚刃、ロングシャンク

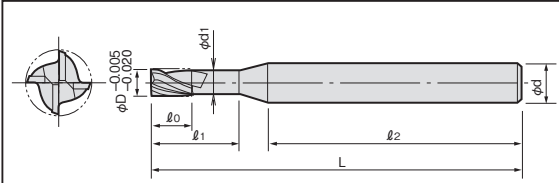

材種：超微粒子超硬合金

形番 Cat. No.	在庫 Stock	寸法 (mm) Dimensions (mm)						
		φD	ℓ <sub>0</sub>	ℓ <sub>1</sub>	ℓ <sub>2</sub>	L	φd <sub>1</sub>	φd
LS-OCFS4-030	<input type="checkbox"/>	3	15	40	98	140	3	4
LS-OCFS4-035	<input type="checkbox"/>	3.5	20	40	99	140	3.5	4
LS-OCFS4-040	<input type="checkbox"/>	4	20	40	96	140	3.95	6
LS-OCFS4-045	<input type="checkbox"/>	4.5	28	50	97	150	4.45	6
LS-OCFS4-050	<input type="checkbox"/>	5	28	50	98	150	4.95	6
LS-OCFS4-055	<input type="checkbox"/>	5.5	30	50	99	150	5.45	6
LS-OCFS4-060	<input type="checkbox"/>	6	30	50	100	150	5.95	6
LS-OCFS4-065	<input type="checkbox"/>	6.5	30	50	100	150	6.45	6
LS-OCFS4-070	<input type="checkbox"/>	7	40	80	97	180	6.9	8
LS-OCFS4-075	<input type="checkbox"/>	7.5	40	80	98	180	7.4	8
LS-OCFS4-080	<input type="checkbox"/>	8	40	80	100	180	7.9	8
LS-OCFS4-085	<input type="checkbox"/>	8.5	40	80	100	180	8.4	8
LS-OCFS4-090	<input type="checkbox"/>	9	50	125	102	230	8.9	10
LS-OCFS4-100	<input type="checkbox"/>	10	50	125	105	230	9.9	10
LS-OCFS4-110	<input type="checkbox"/>	11	50	125	102	230	10.9	12
LS-OCFS4-120	<input type="checkbox"/>	12	50	125	105	230	11.9	12
LS-OCFS4-140	<input type="checkbox"/>	14	70	125	121	250	13.9	16
LS-OCFS4-150	<input type="checkbox"/>	15	70	125	122	250	14.9	16
LS-OCFS4-160	<input type="checkbox"/>	16	70	125	125	250	15.9	16
LS-OCFS4-180	<input type="checkbox"/>	18	70	125	121	250	17.9	20
LS-OCFS4-200	<input type="checkbox"/>	20	70	125	125	250	19.9	20
LS-OCFS4-250	<input type="checkbox"/>	25	70	125	125	250	24.9	25
LS-OCFS4-300	<input type="checkbox"/>	30	80	125	121	250	29.9	32

841

## ソリッド ロングシャンクエンドミル XLS-E2形

●2枚刃、ロングシャンク

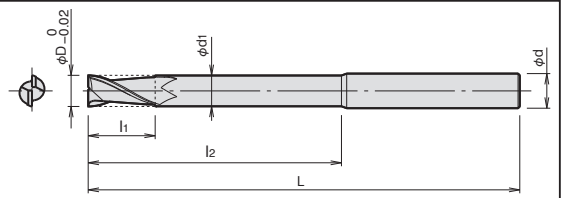

材種：超微粒子超硬合金

形番 Cat. No.	在庫 Stock	寸法 (mm) Dimensions (mm)					
		φD	ℓ <sub>1</sub>	ℓ <sub>2</sub>	L	φd <sub>1</sub>	φd
XLS-E2-2 X140	<input type="checkbox"/>	2	12	40	140	2	4
XLS-E2-2.5X140	<input type="checkbox"/>	2.5	16	40	140	2.5	4
XLS-E2-3 X150	<input type="checkbox"/>	3	20	50	150	3	6
XLS-E2-3.5X150	<input type="checkbox"/>	3.5	22	50	150	3.5	6
XLS-E2-4 X150	<input type="checkbox"/>	4	24	50	150	3.95	6
XLS-E2-4.5X150	<input type="checkbox"/>	4.5	28	50	150	4.45	6
XLS-E2-5 X150	<input type="checkbox"/>	5	30	50	150	4.95	6
XLS-E2-5.5X150	<input type="checkbox"/>	5.5	30	50	150	5.45	6
XLS-E2-6 X150	<input type="checkbox"/>	6	30	50	150	5.95	6
XLS-E2-6.5X150	<input type="checkbox"/>	6.5	30	50	150	6.45	6
XLS-E2-7 X180	<input type="checkbox"/>	7	40	80	180	6.9	8
XLS-E2-7.5X180	<input type="checkbox"/>	7.5	40	80	180	7.4	8
XLS-E2-8 X180	<input type="checkbox"/>	8	40	80	180	7.9	8
XLS-E2-8.5X180	<input type="checkbox"/>	8.5	40	80	180	8.4	8
XLS-E2-9 X230	<input type="checkbox"/>	9	40	130	230	8.9	10
XLS-E2-9.5X230	<input type="checkbox"/>	9.5	40	130	230	9.4	10
XLS-E2-10 X230	<input type="checkbox"/>	10	50	130	230	9.9	10
XLS-E2-11 X240	<input type="checkbox"/>	11	50	140	240	10.9	12
XLS-E2-12 X240	<input type="checkbox"/>	12	50	140	240	11.9	12
XLS-E2-13 X240	<input type="checkbox"/>	13	60	140	240	12.9	12
XLS-E2-14 X250	<input type="checkbox"/>	14	70	150	250	13.9	16
XLS-E2-15 X250	<input type="checkbox"/>	15	70	150	250	14.9	16
XLS-E2-16 X250	<input type="checkbox"/>	16	70	150	250	15.9	16
XLS-E2-18 X250	<input type="checkbox"/>	18	70	150	250	17.9	20
XLS-E2-20 X250	<input type="checkbox"/>	20	70	150	250	19.9	20
XLS-E2-25 X250	<input type="checkbox"/>	25	80	150	250	24.9	25
XLS-E2-30 X250	<input type="checkbox"/>	30	80	150	250	29.9	32

95



## ソリッド ロングシャンクエンドミル XLS-E4形

●4枚刃、ロングシャンク

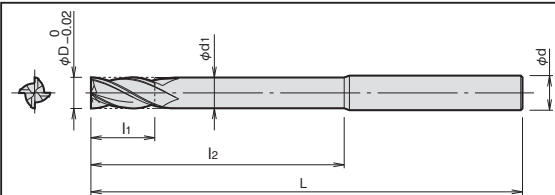

材種：超微粒子超硬合金

形番 Cat. No.	在庫 Stock	寸法 (mm) Dimensions (mm)					
		φD	l <sub>1</sub>	l <sub>2</sub>	L	φd <sub>1</sub>	φd
XLS-E4-3 X150	<input type="checkbox"/>	3	20	50	150	3	6
XLS-E4-3.5X150	<input type="checkbox"/>	3.5	22	50	150	3.5	6
XLS-E4-4 X150	<input type="checkbox"/>	4	24	50	150	3.95	6
XLS-E4-4.5X150	<input type="checkbox"/>	4.5	28	50	150	4.45	6
XLS-E4-5 X150	<input type="checkbox"/>	5	30	50	150	4.95	6
XLS-E4-5.5X150	<input type="checkbox"/>	5.5	30	50	150	5.45	6
XLS-E4-6 X150	<input type="checkbox"/>	6	30	50	150	5.95	6
XLS-E4-6.5X150	<input type="checkbox"/>	6.5	30	50	150	6.45	6
XLS-E4-7 X180	<input type="checkbox"/>	7	40	80	180	6.9	8
XLS-E4-7.5X180	<input type="checkbox"/>	7.5	40	80	180	7.4	8
XLS-E4-8 X180	<input type="checkbox"/>	8	40	80	180	7.9	8
XLS-E4-8.5X180	<input type="checkbox"/>	8.5	40	80	180	8.4	8
XLS-E4-9 X230	<input type="checkbox"/>	9	40	130	230	8.9	10
XLS-E4-9.5X230	<input type="checkbox"/>	9.5	40	130	230	9.4	10
XLS-E4-10 X230	<input type="checkbox"/>	10	50	130	230	9.9	10
XLS-E4-11 X240	<input type="checkbox"/>	11	50	140	240	10.9	12
XLS-E4-12 X240	<input type="checkbox"/>	12	50	140	240	11.9	12
XLS-E4-13 X240	<input type="checkbox"/>	13	60	140	240	12.9	12
XLS-E4-14 X250	<input type="checkbox"/>	14	70	150	250	13.9	16
XLS-E4-15 X250	<input type="checkbox"/>	15	70	150	250	14.9	16
XLS-E4-16 X250	<input type="checkbox"/>	16	70	150	250	15.9	16
XLS-E4-18 X250	<input type="checkbox"/>	18	70	150	250	17.9	20
XLS-E4-20 X250	<input type="checkbox"/>	20	70	150	250	19.9	20
XLS-E4-25 X250	<input type="checkbox"/>	25	80	150	250	24.9	25
XLS-E4-30 X250	<input type="checkbox"/>	30	80	150	250	29.9	32

## ソリッドエンドミル OCFS2-S形

●2枚刃、標準刃長  
ねじれ角30°、コーナC面付き

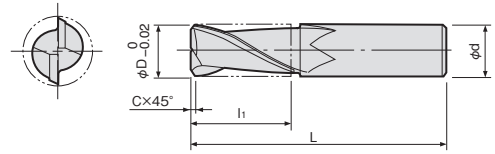

材種：超微粒子超硬合金

形番 Cat. No.	在庫 Stock	寸法 (mm) Dimensions (mm)					
		φD	l <sub>1</sub>	L	φd	C	
OCFS2-010S	<input type="checkbox"/>	1	3	45	6	0.05	
OCFS2-015S	<input type="checkbox"/>	1.5	5	45	6	0.05	
OCFS2-020S	<input type="checkbox"/>	2	6	45	6	0.1	
OCFS2-025S	<input type="checkbox"/>	2.5	8	45	6	0.1	
OCFS2-030S	<input type="checkbox"/>	3	10	45	6	0.1	
OCFS2-035S	<input type="checkbox"/>	3.5	11	45	6	0.1	
OCFS2-040S	<input type="checkbox"/>	4	12	45	6	0.1	
OCFS2-045S	<input type="checkbox"/>	4.5	14	45	6	0.1	
OCFS2-050S	<input type="checkbox"/>	5	15	50	6	0.1	
OCFS2-055S	<input type="checkbox"/>	5.5	15	50	6	0.2	
OCFS2-060S	<input type="checkbox"/>	6	15	50	6	0.2	
OCFS2-065S	<input type="checkbox"/>	6.5	15	50	6	0.2	
OCFS2-070S	<input type="checkbox"/>	7	20	60	8	0.2	
OCFS2-075S	<input type="checkbox"/>	7.5	20	60	8	0.2	
OCFS2-080S	<input type="checkbox"/>	8	20	60	8	0.2	
OCFS2-085S	<input type="checkbox"/>	8.5	20	60	8	0.2	
OCFS2-090S	<input type="checkbox"/>	9	20	65	10	0.2	
OCFS2-095S	<input type="checkbox"/>	9.5	20	65	10	0.2	
OCFS2-100S	<input type="checkbox"/>	10	25	70	10	0.2	
OCFS2-105S	<input type="checkbox"/>	10.5	25	70	10	0.2	
OCFS2-110S	<input type="checkbox"/>	11	25	75	12	0.2	
OCFS2-115S	<input type="checkbox"/>	11.5	25	75	12	0.2	
OCFS2-120S	<input type="checkbox"/>	12	25	75	12	0.2	
OCFS2-125S	<input type="checkbox"/>	12.5	30	80	12	0.2	
OCFS2-130S	<input type="checkbox"/>	13	30	80	12	0.2	
OCFS2-135S	<input type="checkbox"/>	13.5	35	90	16	0.2	
OCFS2-140S	<input type="checkbox"/>	14	35	90	16	0.2	
OCFS2-145S	<input type="checkbox"/>	14.5	35	90	16	0.2	
OCFS2-150S	<input type="checkbox"/>	15	35	90	16	0.2	
OCFS2-155S	<input type="checkbox"/>	15.5	35	90	16	0.3	
OCFS2-160S	<input type="checkbox"/>	16	35	90	16	0.3	
OCFS2-165S	<input type="checkbox"/>	16.5	40	105	20	0.3	
OCFS2-170S	<input type="checkbox"/>	17	40	105	20	0.3	
OCFS2-175S	<input type="checkbox"/>	17.5	40	105	20	0.3	
OCFS2-180S	<input type="checkbox"/>	18	40	105	20	0.3	
OCFS2-185S	<input type="checkbox"/>	18.5	40	105	20	0.4	
OCFS2-190S	<input type="checkbox"/>	19	40	105	20	0.4	
OCFS2-195S	<input type="checkbox"/>	19.5	40	105	20	0.5	
OCFS2-200S	<input type="checkbox"/>	20	40	105	20	0.5	
OCFS2-210S	<input type="checkbox"/>	21	50	120	25	0.5	
OCFS2-220S	<input type="checkbox"/>	22	50	120	25	0.5	
OCFS2-230S	<input type="checkbox"/>	23	50	120	25	0.5	
OCFS2-240S	<input type="checkbox"/>	24	50	120	25	0.5	
OCFS2-250S	<input type="checkbox"/>	25	50	120	25	0.5	
OCFS2-260S	<input type="checkbox"/>	26	50	120	25	0.5	
OCFS2-270S	<input type="checkbox"/>	27	50	120	25	0.5	
OCFS2-280S	<input type="checkbox"/>	28	60	130	25	0.5	
OCFS2-290S	<input type="checkbox"/>	29	60	130	25	0.5	
OCFS2-300S	<input type="checkbox"/>	30	60	130	32	0.5	



## ソリッドエンドミル OCFS2-M形

●ミニチュアタイプ



## ソリッドエンドミル OCFS2-L形

●2枚刃、ロング刃長  
ねじれ角30°、コーナC面付き

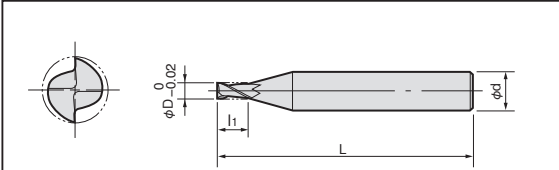

材種：超微粒子超硬合金

形番 Cat. No.	在庫 Stock	寸法 (mm) Dimensions (mm)			
		φD	l <sub>1</sub>	L	φd
OCFS2-010M	<input type="checkbox"/>	1.0	3.0	38	3
OCFS2-011M	<input type="checkbox"/>	1.1	3.3	38	3
OCFS2-012M	<input type="checkbox"/>	1.2	3.6	38	3
OCFS2-013M	<input type="checkbox"/>	1.3	3.9	38	3
OCFS2-014M	<input type="checkbox"/>	1.4	4.2	38	3
OCFS2-015M	<input type="checkbox"/>	1.5	4.5	38	3
OCFS2-016M	<input type="checkbox"/>	1.6	4.8	38	3
OCFS2-017M	<input type="checkbox"/>	1.7	5.1	38	3
OCFS2-018M	<input type="checkbox"/>	1.8	5.4	38	3
OCFS2-019M	<input type="checkbox"/>	1.9	5.7	38	3
OCFS2-020M	<input type="checkbox"/>	2.0	6.0	38	3
OCFS2-025M	<input type="checkbox"/>	2.5	7.5	38	3
OCFS2-030M	<input type="checkbox"/>	3.0	9.0	38	3

914

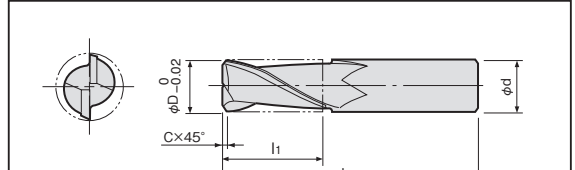

材種：超微粒子超硬合金

形番 Cat. No.	在庫 Stock	寸法 (mm) Dimensions (mm)				
		φD	l <sub>1</sub>	L	φd	C
OCFS2-030L	<input type="checkbox"/>	3	20	60	6	0.1
OCFS2-035L	<input type="checkbox"/>	3.5	22	60	6	0.1
OCFS2-040L	<input type="checkbox"/>	4	24	60	6	0.1
OCFS2-045L	<input type="checkbox"/>	4.5	28	60	6	0.1
OCFS2-050L	<input type="checkbox"/>	5	30	70	6	0.1
OCFS2-055L	<input type="checkbox"/>	5.5	30	70	6	0.2
OCFS2-060L	<input type="checkbox"/>	6	30	70	6	0.2
OCFS2-065L	<input type="checkbox"/>	6.5	40	90	8	0.2
OCFS2-070L	<input type="checkbox"/>	7	40	90	8	0.2
OCFS2-075L	<input type="checkbox"/>	7.5	40	90	8	0.2
OCFS2-080L	<input type="checkbox"/>	8	40	90	8	0.2
OCFS2-085L	<input type="checkbox"/>	8.5	40	100	10	0.2
OCFS2-090L	<input type="checkbox"/>	9	40	100	10	0.2
OCFS2-095L	<input type="checkbox"/>	9.5	40	100	10	0.2
OCFS2-100L	<input type="checkbox"/>	10	50	110	10	0.2
OCFS2-105L	<input type="checkbox"/>	10.5	50	110	12	0.2
OCFS2-110L	<input type="checkbox"/>	11	50	110	12	0.2
OCFS2-115L	<input type="checkbox"/>	11.5	50	110	12	0.2
OCFS2-120L	<input type="checkbox"/>	12	50	110	12	0.2
OCFS2-125L	<input type="checkbox"/>	12.5	60	120	12	0.2
OCFS2-130L	<input type="checkbox"/>	13	60	120	12	0.2
OCFS2-135L	<input type="checkbox"/>	13.5	70	130	16	0.2
OCFS2-140L	<input type="checkbox"/>	14	70	130	16	0.2
OCFS2-145L	<input type="checkbox"/>	14.5	70	130	16	0.2
OCFS2-150L	<input type="checkbox"/>	15	70	130	16	0.2
OCFS2-155L	<input type="checkbox"/>	15.5	70	130	16	0.3
OCFS2-160L	<input type="checkbox"/>	16	70	130	16	0.3
OCFS2-165L	<input type="checkbox"/>	16.5	70	140	20	0.3
OCFS2-170L	<input type="checkbox"/>	17	70	140	20	0.3
OCFS2-175L	<input type="checkbox"/>	17.5	70	140	20	0.3
OCFS2-180L	<input type="checkbox"/>	18	70	140	20	0.3
OCFS2-185L	<input type="checkbox"/>	18.5	70	140	20	0.4
OCFS2-190L	<input type="checkbox"/>	19	70	140	20	0.4
OCFS2-195L	<input type="checkbox"/>	19.5	70	140	20	0.5
OCFS2-200L	<input type="checkbox"/>	20	70	140	20	0.5
OCFS2-210L	<input type="checkbox"/>	21	80	150	25	0.5
OCFS2-220L	<input type="checkbox"/>	22	80	150	25	0.5
OCFS2-230L	<input type="checkbox"/>	23	80	150	25	0.5
OCFS2-240L	<input type="checkbox"/>	24	80	150	25	0.5
OCFS2-250L	<input type="checkbox"/>	25	80	150	25	0.5

7514

## ソリッドエンドミル OCFS4-L形

- 4枚刃、ロング刃長  
ねじれ角30°、コーナC面付き



## ソリッドエンドミル OCFS4-S形

- 4枚刃、標準刃長  
ねじれ角30°、コーナC面付き

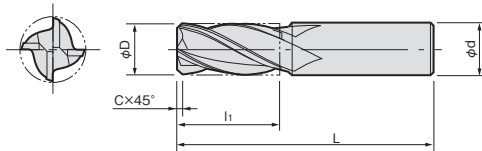

材種: 超微粒子超硬合金

形番 Cat. No.	在庫 Stock	寸法 (mm) Dimensions (mm)				
		φD	li	L	φd	C
OCFS4-030L	□	3	20	60	6	0.1
OCFS4-035L	□	3.5	22	60	6	0.1
OCFS4-040L	□	4	24	60	6	0.1
OCFS4-045L	□	4.5	28	60	6	0.1
OCFS4-050L	□	5	30	70	6	0.1
OCFS4-055L	□	5.5	30	70	6	0.2
OCFS4-060L	□	6	30	70	6	0.2
OCFS4-065L	□	6.5	40	90	8	0.2
OCFS4-070L	□	7	40	90	8	0.2
OCFS4-075L	□	7.5	40	90	8	0.2
OCFS4-080L	□	8	40	90	8	0.2
OCFS4-085L	□	8.5	40	100	10	0.2
OCFS4-090L	□	9	40	100	10	0.2
OCFS4-095L	□	9.5	40	100	10	0.2
OCFS4-100L	□	10	50	110	10	0.2
OCFS4-105L	□	10.5	50	110	12	0.2
OCFS4-110L	□	11	50	110	12	0.2
OCFS4-115L	□	11.5	50	110	12	0.2
OCFS4-120L	□	12	50	110	12	0.2
OCFS4-125L	□	12.5	60	120	12	0.2
OCFS4-130L	□	13	60	120	12	0.2
OCFS4-135L	□	13.5	70	130	16	0.2
OCFS4-140L	□	14	70	130	16	0.2
OCFS4-145L	□	14.5	70	130	16	0.2
OCFS4-150L	□	15	70	130	16	0.2
OCFS4-155L	□	15.5	70	130	16	0.3
OCFS4-160L	□	16	70	130	16	0.3
OCFS4-165L	□	16.5	70	140	20	0.3
OCFS4-170L	□	17	70	140	20	0.3
OCFS4-175L	□	17.5	70	140	20	0.3
OCFS4-180L	□	18	70	140	20	0.3
OCFS4-185L	□	18.5	70	140	20	0.4
OCFS4-190L	□	19	70	140	20	0.4
OCFS4-195L	□	19.5	70	140	20	0.5
OCFS4-200L	□	20	70	140	20	0.5
OCFS4-210L	□	21	80	150	25	0.5
OCFS4-220L	□	22	80	150	25	0.5
OCFS4-230L	□	23	80	150	25	0.5
OCFS4-240L	□	24	80	150	25	0.5
OCFS4-250L	□	25	80	150	25	0.5

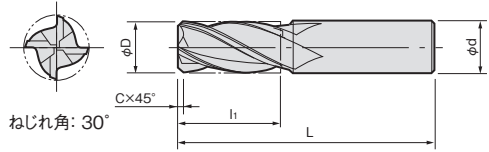

材種: 超微粒子超硬合金

形番 Cat. No.	在庫 Stock	寸法 (mm) Dimensions (mm)				
		φD	li	L	φd	C
OCFS4-030S	□	3	10	45	6	0.1
OCFS4-035S	□	3.5	11	45	6	0.1
OCFS4-040S	□	4	12	45	6	0.1
OCFS4-045S	□	4.5	14	45	6	0.1
OCFS4-050S	□	5	15	50	6	0.1
OCFS4-055S	□	5.5	15	50	6	0.2
OCFS4-060S	□	6	15	50	6	0.2
OCFS4-065S	□	6.5	15	50	6	0.2
OCFS4-070S	□	7	20	60	8	0.2
OCFS4-075S	□	7.5	20	60	8	0.2
OCFS4-080S	□	8	20	60	8	0.2
OCFS4-085S	□	8.5	20	60	8	0.2
OCFS4-090S	□	9	20	65	10	0.2
OCFS4-095S	□	9.5	20	65	10	0.2
OCFS4-100S	□	10	25	70	10	0.2
OCFS4-105S	□	10.5	25	70	10	0.2
OCFS4-110S	□	11	25	75	12	0.2
OCFS4-115S	□	11.5	25	75	12	0.2
OCFS4-120S	□	12	25	75	12	0.2
OCFS4-125S	□	12.5	30	80	12	0.2
OCFS4-130S	□	13	30	80	12	0.2
OCFS4-135S	□	13.5	35	90	16	0.2
OCFS4-140S	□	14	35	90	16	0.2
OCFS4-145S	□	14.5	35	90	16	0.2
OCFS4-150S	□	15	35	90	16	0.2
OCFS4-155S	□	15.5	35	90	16	0.3
OCFS4-160S	□	16	35	90	16	0.3
OCFS4-165S	□	16.5	40	105	20	0.3
OCFS4-170S	□	17	40	105	20	0.3
OCFS4-175S	□	17.5	40	105	20	0.3
OCFS4-180S	□	18	40	105	20	0.3
OCFS4-185S	□	18.5	40	105	20	0.4
OCFS4-190S	□	19	40	105	20	0.4
OCFS4-195S	□	19.5	40	105	20	0.5
OCFS4-200S	□	20	40	105	20	0.5
OCFS4-210S	□	21	50	120	25	0.5
OCFS4-220S	□	22	50	120	25	0.5
OCFS4-230S	□	23	50	120	25	0.5
OCFS4-240S	□	24	50	120	25	0.5
OCFS4-250S	□	25	50	120	25	0.5
OCFS4-260S	□	26	50	120	25	0.5
OCFS4-270S	□	27	50	120	25	0.5
OCFS4-280S	□	28	60	130	25	0.5
OCFS4-290S	□	29	60	130	25	0.5
OCFS4-300S	□	30	60	130	32	0.5

# ソリッドエンドミル

# SED-R形

- 2枚刃、ラジアスエンドミル
- コーナR付き、エキセントリックリリーフ形、ねじれ角30°

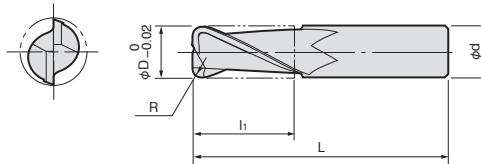

材種：超微粒子超硬合金

形番 Cat. No.	在庫 Stock	寸法 (mm) Dimensions (mm)					形番 Cat. No.	在庫 Stock	寸法 (mm) Dimensions (mm)					
		R	φD	l1	L	φd			R	φD	l1	L	φd	
SED-2030-R0.5	<input type="checkbox"/>	0.5	3	10	45	6	SED-2050-R2.0	<input type="checkbox"/>	2.0	5	15	50	6	
SED-2040-R0.5	<input type="checkbox"/>		4	12	45	6	SED-2060-R2.0	<input type="checkbox"/>		6	15	55	6	
SED-2050-R0.5	<input type="checkbox"/>		5	15	50	6	SED-2080-R2.0	<input type="checkbox"/>		8	20	65	8	
SED-2060-R0.5	<input type="checkbox"/>		6	15	55	6	SED-2100-R2.0	<input type="checkbox"/>		10	25	75	10	
SED-2080-R0.5	<input type="checkbox"/>		8	20	65	8	SED-2120-R2.0	<input type="checkbox"/>		12	25	80	12	
SED-2100-R0.5	<input type="checkbox"/>		10	25	75	10	SED-2130-R2.0	<input type="checkbox"/>		13	28	85	12	
SED-2120-R0.5	<input type="checkbox"/>		12	25	80	12	SED-2140-R2.0	<input type="checkbox"/>		14	28	85	12	
SED-2130-R0.5	<input type="checkbox"/>		13	28	85	12	SED-2150-R2.0	<input type="checkbox"/>		15	30	100	16	
SED-2140-R0.5	<input type="checkbox"/>		14	28	85	12	SED-2160-R2.0	<input type="checkbox"/>		16	35	100	16	
SED-2150-R0.5	<input type="checkbox"/>		15	30	100	16	SED-2180-R2.0	<input type="checkbox"/>		18	40	115	20	
SED-2160-R0.5	<input type="checkbox"/>		16	35	100	16	SED-2200-R2.0	<input type="checkbox"/>		20	45	115	20	
SED-2180-R0.5	<input type="checkbox"/>		18	40	115	20	SED-2060-R2.5	<input type="checkbox"/>		2.5	6	15	55	6
SED-2200-R0.5	<input type="checkbox"/>	20	45	115	20	SED-2080-R2.5	<input type="checkbox"/>	8	20		65	8		
SED-2030-R1.0	<input type="checkbox"/>	1.0	3	10	45	6	SED-2100-R2.5	<input type="checkbox"/>	10		25	75	10	
SED-2040-R1.0	<input type="checkbox"/>		4	12	45	6	SED-2120-R2.5	<input type="checkbox"/>	12		25	80	12	
SED-2050-R1.0	<input type="checkbox"/>		5	15	50	6	SED-2130-R2.5	<input type="checkbox"/>	13		28	85	12	
SED-2060-R1.0	<input type="checkbox"/>		6	15	55	6	SED-2140-R2.5	<input type="checkbox"/>	14		28	85	12	
SED-2080-R1.0	<input type="checkbox"/>		8	20	65	8	SED-2150-R2.5	<input type="checkbox"/>	15		30	100	16	
SED-2100-R1.0	<input type="checkbox"/>		10	25	75	10	SED-2160-R2.5	<input type="checkbox"/>	16		35	100	16	
SED-2120-R1.0	<input type="checkbox"/>		12	25	80	12	SED-2180-R2.5	<input type="checkbox"/>	18		40	115	20	
SED-2130-R1.0	<input type="checkbox"/>		13	28	85	12	SED-2200-R2.5	<input type="checkbox"/>	20		45	115	20	
SED-2140-R1.0	<input type="checkbox"/>		14	28	85	12	SED-2080-R3.0	<input type="checkbox"/>	3.0		8	20	65	8
SED-2150-R1.0	<input type="checkbox"/>		15	30	100	16	SED-2100-R3.0	<input type="checkbox"/>			10	25	75	10
SED-2160-R1.0	<input type="checkbox"/>		16	35	100	16	SED-2120-R3.0	<input type="checkbox"/>		12	25	80	12	
SED-2180-R1.0	<input type="checkbox"/>		18	40	115	20	SED-2130-R3.0	<input type="checkbox"/>		13	28	85	12	
SED-2200-R1.0	<input type="checkbox"/>	20	45	115	20	SED-2140-R3.0	<input type="checkbox"/>	14		28	85	12		
SED-2040-R1.5	<input type="checkbox"/>	1.5	4	12	45	6	SED-2150-R3.0	<input type="checkbox"/>		15	30	100	16	
SED-2050-R1.5	<input type="checkbox"/>		5	15	50	6	SED-2160-R3.0	<input type="checkbox"/>		16	35	100	16	
SED-2060-R1.5	<input type="checkbox"/>		6	15	55	6	SED-2180-R3.0	<input type="checkbox"/>		18	40	115	20	
SED-2080-R1.5	<input type="checkbox"/>		8	20	65	8	SED-2200-R3.0	<input type="checkbox"/>		20	45	115	20	
SED-2100-R1.5	<input type="checkbox"/>		10	25	75	10	SED-2100-R4.0	<input type="checkbox"/>		4.0	10	25	75	10
SED-2120-R1.5	<input type="checkbox"/>		12	25	80	12	SED-2120-R4.0	<input type="checkbox"/>			12	25	80	12
SED-2130-R1.5	<input type="checkbox"/>		13	28	85	12	SED-2130-R4.0	<input type="checkbox"/>			13	28	85	12
SED-2140-R1.5	<input type="checkbox"/>		14	28	85	12	SED-2140-R4.0	<input type="checkbox"/>	14		28	85	12	
SED-2150-R1.5	<input type="checkbox"/>		15	30	100	16	SED-2150-R4.0	<input type="checkbox"/>	15		30	100	16	
SED-2160-R1.5	<input type="checkbox"/>		16	35	100	16	SED-2160-R4.0	<input type="checkbox"/>	16		35	100	16	
SED-2180-R1.5	<input type="checkbox"/>		18	40	115	20	SED-2180-R4.0	<input type="checkbox"/>	18		40	115	20	
SED-2200-R1.5	<input type="checkbox"/>		20	45	115	20	SED-2200-R4.0	<input type="checkbox"/>	20		45	115	20	
						SED-2120-R5.0	<input type="checkbox"/>	5.0	12		25	80	12	
						SED-2130-R5.0	<input type="checkbox"/>		13		28	85	12	
						SED-2140-R5.0	<input type="checkbox"/>		14		28	85	12	
						SED-2150-R5.0	<input type="checkbox"/>		15		30	100	16	
						SED-2160-R5.0	<input type="checkbox"/>		16	35	100	16		
						SED-2180-R5.0	<input type="checkbox"/>		18	40	115	20		
						SED-2200-R5.0	<input type="checkbox"/>		20	45	115	20		

## 樹脂加工専用 ロングネックエンドミル PS-SED形

●2枚刃、ロングネックエンドミル

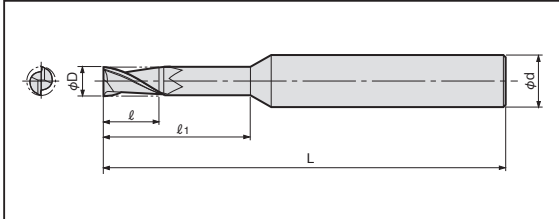

形番 Cat. No.	在庫 Stock	寸法 (mm) Dimensions (mm)				
		φD	ℓ	ℓ <sub>1</sub>	L	φd
PS-SED2004-3	<input type="checkbox"/>	0.4	0.8	3	38	3
PS-SED2005-4	<input type="checkbox"/>	0.5	1	4	38	3
PS-SED2005-6	<input type="checkbox"/>	0.5	1	6	38	3
PS-SED2008-8	<input type="checkbox"/>	0.8	1.6	8	45	4
PS-SED2010-6	<input type="checkbox"/>	1	2	6	45	4
PS-SED2010-8	<input type="checkbox"/>	1	2	8	45	4
PS-SED2010-10	<input type="checkbox"/>	1	2	10	45	4
PS-SED2010-12	<input type="checkbox"/>	1	2	12	45	4
PS-SED2015-6	<input type="checkbox"/>	1.5	3	6	45	4
PS-SED2015-10	<input type="checkbox"/>	1.5	3	10	45	4
PS-SED2015-16	<input type="checkbox"/>	1.5	3	16	50	4
PS-SED2015-21	<input type="checkbox"/>	1.5	3	21	55	4
PS-SED2020-8	<input type="checkbox"/>	2	4	8	50	4
PS-SED2020-10	<input type="checkbox"/>	2	4	10	50	4
PS-SED2020-12	<input type="checkbox"/>	2	4	12	50	4
PS-SED2020-14	<input type="checkbox"/>	2	4	14	50	4
PS-SED2020-16	<input type="checkbox"/>	2	4	16	50	4
PS-SED2020-21	<input type="checkbox"/>	2	4	21	55	4
PS-SED2030-16	<input type="checkbox"/>	3	6	16	70	6
PS-SED2030-21	<input type="checkbox"/>	3	6	21	70	6
PS-SED2030-26	<input type="checkbox"/>	3	6	26	70	6
PS-SED2040-18	<input type="checkbox"/>	4	8	18	70	6
PS-SED2040-24	<input type="checkbox"/>	4	8	24	70	6
PS-SED2040-32	<input type="checkbox"/>	4	8	32	70	6
PS-SED2040-42	<input type="checkbox"/>	4	8	42	80	6
PS-SED2060-42	<input type="checkbox"/>	6	12	42	80	6

## テーパエンドミル DYK7形

●2枚テーパ刃、直刃

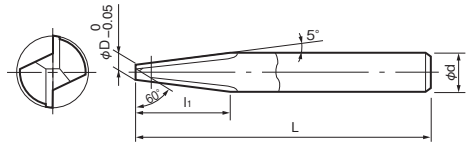

材種：超微粒子超硬合金

形番 Cat. No.	在庫 Stock	寸法 (mm) Dimensions (mm)			
		φD	ℓ <sub>1</sub>	L	φd
DYK-701	<input type="checkbox"/>	2	22.9	70	6
DYK-702	<input type="checkbox"/>	2	34.3	80	8
DYK-703	<input type="checkbox"/>	3	17.1	70	6
DYK-704	<input type="checkbox"/>	3	28.6	80	8
DYK-705	<input type="checkbox"/>	3	40	90	10
DYK-706	<input type="checkbox"/>	3	51.4	100	12
DYK-707	<input type="checkbox"/>	4	11.4	70	6
DYK-708	<input type="checkbox"/>	4	22.9	80	8
DYK-709	<input type="checkbox"/>	4	34.3	90	10
DYK-710	<input type="checkbox"/>	4	45.7	100	12
DYK-711	<input type="checkbox"/>	5	28.6	90	10
DYK-712	<input type="checkbox"/>	5	40	100	12
DYK-713	<input type="checkbox"/>	6	34.3	100	12



## ソリッドエンドミル

## DES2-S形

- 2枚刃、標準刃長
- 超ミニチュアタイプ

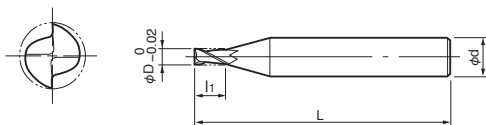

材種：超微粒子超硬合金

形番 Cat. No.	在庫 Stock	寸法 (mm) Dimensions (mm)					形番 Cat. No.	在庫 Stock	寸法 (mm) Dimensions (mm)				
		φD	l <sub>1</sub>	L	φd				φD	l <sub>1</sub>	L	φd	
DES2-0020S	□	0.20	0.4	40	3		DES2-0225S	□	2.25	6.0	40	4	
DES2-0025S	□	0.25	0.5	40	3		DES2-0230S	□	2.30	6.0	40	4	
DES2-0030S	□	0.30	1.0	40	3		DES2-0235S	□	2.35	6.0	40	4	
DES2-0035S	□	0.35	1.0	40	3		DES2-0240S	□	2.40	6.0	40	4	
DES2-0040S	□	0.40	1.2	40	3		DES2-0245S	□	2.45	8.0	40	4	
DES2-0045S	□	0.45	1.2	40	3		DES2-0250S	□	2.50	8.0	40	4	
DES2-0050S	□	0.50	1.5	40	3		DES2-0255S	□	2.55	8.0	40	4	
DES2-0055S	□	0.55	1.5	40	3		DES2-0260S	□	2.60	8.0	40	4	
DES2-0060S	□	0.60	2.0	40	3		DES2-0265S	□	2.65	8.0	40	4	
DES2-0065S	□	0.65	2.0	40	3		DES2-0270S	□	2.70	8.0	40	4	
DES2-0070S	□	0.70	2.0	40	3		DES2-0275S	□	2.75	8.0	40	4	
DES2-0075S	□	0.75	2.0	40	3		DES2-0280S	□	2.80	8.0	40	4	
DES2-0080S	□	0.80	2.5	40	3		DES2-0285S	□	2.85	8.0	40	4	
DES2-0085S	□	0.85	2.5	40	3		DES2-0290S	□	2.90	8.0	45	4	
DES2-0090S	□	0.90	2.5	40	3		DES2-0295S	□	2.95	8.0	45	4	
DES2-0095S	□	0.95	2.5	40	3		DES2-0300S	□	3.00	8.0	45	6	
DES2-0100S	□	1.00	3.0	40	4		DES2-0305S	□	3.05	8.0	45	6	
DES2-0105S	□	1.05	3.0	40	4		DES2-0310S	□	3.10	8.0	45	6	
DES2-0110S	□	1.10	3.0	40	4		DES2-0315S	□	3.15	8.0	45	6	
DES2-0115S	□	1.15	3.0	40	4		DES2-0320S	□	3.20	8.0	45	6	
DES2-0120S	□	1.20	3.0	40	4		DES2-0325S	□	3.25	8.0	45	6	
DES2-0125S	□	1.25	3.0	40	4		DES2-0330S	□	3.30	8.0	45	6	
DES2-0130S	□	1.30	3.0	40	4		DES2-0335S	□	3.35	8.0	45	6	
DES2-0135S	□	1.35	3.0	40	4		DES2-0340S	□	3.40	8.0	45	6	
DES2-0140S	□	1.40	3.0	40	4		DES2-0345S	□	3.45	8.0	45	6	
DES2-0145S	□	1.45	3.0	40	4		DES2-0350S	□	3.50	10.0	45	6	
DES2-0150S	□	1.50	5.0	40	4		DES2-0355S	□	3.55	10.0	45	6	
DES2-0155S	□	1.55	5.0	40	4		DES2-0360S	□	3.60	10.0	45	6	
DES2-0160S	□	1.60	5.0	40	4		DES2-0365S	□	3.65	10.0	45	6	
DES2-0165S	□	1.65	5.0	40	4		DES2-0370S	□	3.70	10.0	45	6	
DES2-0170S	□	1.70	5.0	40	4		DES2-0375S	□	3.75	10.0	45	6	
DES2-0175S	□	1.75	5.0	40	4		DES2-0380S	□	3.80	10.0	45	6	
DES2-0180S	□	1.80	5.0	40	4		DES2-0385S	□	3.85	10.0	45	6	
DES2-0185S	□	1.85	5.0	40	4		DES2-0390S	□	3.90	10.0	45	6	
DES2-0190S	□	1.90	5.0	40	4		DES2-0395S	□	3.95	10.0	45	6	
DES2-0195S	□	1.95	5.0	40	4		DES2-0400S	□	4.00	12.0	45	6	
DES2-0200S	□	2.00	6.0	40	4		DES2-0405S	□	4.05	12.0	45	6	
DES2-0205S	□	2.05	6.0	40	4		DES2-0410S	□	4.10	12.0	45	6	
DES2-0210S	□	2.10	6.0	40	4		DES2-0415S	□	4.15	12.0	45	6	
DES2-0215S	□	2.15	6.0	40	4		DES2-0420S	□	4.20	12.0	45	6	
DES2-0220S	□	2.20	6.0	40	4		DES2-0425S	□	4.25	12.0	45	6	



## ソリッドエンドミル DES2-S形

## ソリッドエンドミル DES2-L形

- 2枚刃、ロング刃長
- 超ミニチュアタイプ

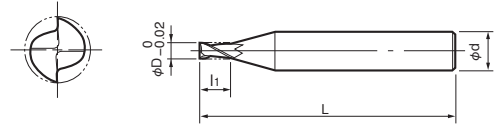

材種：超微粒子超硬合金

(前ページの続き)

形番 Cat. No.	在庫 Stock	寸法 (mm) Dimensions (mm)			
		φD	l <sub>1</sub>	L	φd
DES2-0430S	□	4.30	12.0	45	6
DES2-0435S	□	4.35	12.0	45	6
DES2-0440S	□	4.40	12.0	45	6
DES2-0445S	□	4.45	12.0	45	6
DES2-0450S	□	4.50	12.0	45	6
DES2-0455S	□	4.55	12.0	45	6
DES2-0460S	□	4.60	12.0	45	6
DES2-0465S	□	4.65	12.0	45	6
DES2-0470S	□	4.70	12.0	45	6
DES2-0475S	□	4.75	12.0	45	6
DES2-0480S	□	4.80	12.0	45	6
DES2-0485S	□	4.85	12.0	45	6
DES2-0490S	□	4.90	12.0	45	6
DES2-0495S	□	4.95	12.0	45	6
DES2-0500S	□	5.00	15.0	60	6
DES2-0505S	□	5.05	15.0	60	6
DES2-0510S	□	5.10	15.0	60	6
DES2-0515S	□	5.15	15.0	60	6
DES2-0520S	□	5.20	15.0	60	6
DES2-0525S	□	5.25	15.0	60	6
DES2-0530S	□	5.30	15.0	60	6
DES2-0535S	□	5.35	15.0	60	6
DES2-0540S	□	5.40	15.0	60	6
DES2-0545S	□	5.45	15.0	60	6
DES2-0550S	□	5.50	15.0	60	6
DES2-0555S	□	5.55	15.0	60	6
DES2-0560S	□	5.60	15.0	60	6
DES2-0565S	□	5.65	15.0	60	6
DES2-0570S	□	5.70	15.0	60	6
DES2-0575S	□	5.75	15.0	60	6
DES2-0580S	□	5.80	15.0	60	6
DES2-0585S	□	5.85	15.0	60	6
DES2-0590S	□	5.90	15.0	60	6
DES2-0595S	□	5.95	15.0	60	6
DES2-0600S	□	6.00	15.0	60	6
DES2-0605S	□	6.05	15.0	60	6

形番 Cat. No.	在庫 Stock	寸法 (mm) Dimensions (mm)			
		φD	l <sub>1</sub>	L	φd
DES2-0020L	□	0.2	1.5	40	3
DES2-0030L	□	0.3	2.0	40	3
DES2-0040L	□	0.4	2.5	40	3
DES2-0050L	□	0.5	3.0	40	3
DES2-0060L	□	0.6	3.5	40	3
DES2-0070L	□	0.7	4.5	40	3
DES2-0080L	□	0.8	5.0	40	3
DES2-0090L	□	0.9	5.5	40	3
DES2-0100L-5	□	1.0	5.0	40	4
DES2-0100L-6	□	1.0	6.0	40	4
DES2-0100L-7.5	□	1.0	7.5	40	4
DES2-0100L-10	□	1.0	10.0	40	4
DES2-0110L	□	1.1	7.5	40	4
DES2-0120L	□	1.2	7.5	40	4
DES2-0130L	□	1.3	8.0	40	4
DES2-0140L	□	1.4	8.5	40	4
DES2-0150L-10	□	1.5	10.0	40	4
DES2-0150L-15	□	1.5	15.0	45	4
DES2-0160L	□	1.6	10.0	40	4
DES2-0170L	□	1.7	10.0	40	4
DES2-0180L	□	1.8	10.0	40	4
DES2-0190L	□	1.9	10.0	40	4
DES2-0200L-10	□	2.0	10.0	40	4
DES2-0200L-12	□	2.0	12.0	40	4
DES2-0200L-15	□	2.0	15.0	45	4
DES2-0200L-20	□	2.0	20.0	55	4
DES2-0210L	□	2.1	15.0	45	4
DES2-0220L	□	2.2	15.0	45	4
DES2-0230L	□	2.3	15.0	45	4
DES2-0240L	□	2.4	15.0	45	4
DES2-0250L-15	□	2.5	15.0	50	4
DES2-0250L-20	□	2.5	20.0	55	4
DES2-0260L	□	2.6	15.0	50	4
DES2-0270L	□	2.7	15.0	50	4
DES2-0280L	□	2.8	15.0	50	4
DES2-0290L	□	2.9	15.0	50	4
DES2-0300L-20	□	3.0	20.0	55	4
DES2-0300L-25	□	3.0	25.0	70	4
DES2-0300L-30	□	3.0	30.0	70	4

## 付け刃エンドミル

## OCEB形

- 2枚刃・中心刃付き・外周チップ継目無し、エキセントリックリリーフ形、ねじれ角30°

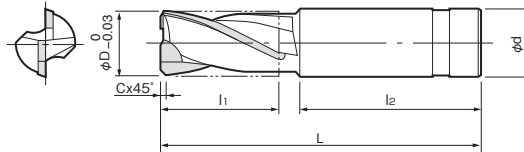

材種：超硬K種(鋳鉄用)

形番 Cat. No.	在庫 Stock	寸法 (mm) Dimensions (mm)					
		φD	l <sub>1</sub>	l <sub>2</sub>	L	φd	C
OCEB-100	●	10	20	55	80	12	0.15~0.2
OCEB-101	□	10.1	20	55	80	12	0.15~0.2
OCEB-102	□	10.2	20	55	80	12	0.15~0.2
OCEB-103	□	10.3	20	55	80	12	0.15~0.2
OCEB-104	□	10.4	20	55	80	12	0.15~0.2
OCEB-105	□	10.5	20	55	80	12	0.15~0.2
OCEB-106	□	10.6	20	55	80	12	0.15~0.2
OCEB-107	□	10.7	20	55	80	12	0.15~0.2
OCEB-108	□	10.8	20	55	80	12	0.15~0.2
OCEB-109	□	10.9	20	55	80	12	0.15~0.2
OCEB-110	●	11	20	55	80	12	0.15~0.2
OCEB-111	□	11.1	20	55	80	12	0.15~0.2
OCEB-112	□	11.2	20	55	80	12	0.15~0.2
OCEB-113	□	11.3	20	55	80	12	0.15~0.2
OCEB-114	□	11.4	20	55	80	12	0.15~0.2
OCEB-115	□	11.5	20	55	80	12	0.15~0.2
OCEB-116	□	11.6	20	55	80	12	0.15~0.2
OCEB-117	□	11.7	20	55	80	12	0.15~0.2
OCEB-118	□	11.8	20	55	80	12	0.15~0.2
OCEB-119	□	11.9	20	55	80	12	0.15~0.2
OCEB-120	●	12	20	55	80	12	0.15~0.2
OCEB-121	□	12.1	25	60	95	16	0.15~0.2
OCEB-122	□	12.2	25	60	95	16	0.15~0.2
OCEB-123	□	12.3	25	60	95	16	0.15~0.2
OCEB-124	□	12.4	25	60	95	16	0.15~0.2
OCEB-125	□	12.5	25	60	95	16	0.15~0.2
OCEB-126	□	12.6	25	60	95	16	0.15~0.2
OCEB-127	□	12.7	25	60	95	16	0.15~0.2
OCEB-128	□	12.8	25	60	95	16	0.15~0.2
OCEB-129	□	12.9	25	60	95	16	0.15~0.2
OCEB-130	●	13	25	60	95	16	0.15~0.2
OCEB-131	□	13.1	25	60	95	16	0.15~0.2
OCEB-132	□	13.2	25	60	95	16	0.15~0.2
OCEB-133	□	13.3	25	60	95	16	0.15~0.2
OCEB-134	□	13.4	25	60	95	16	0.15~0.2
OCEB-135	□	13.5	25	60	95	16	0.15~0.2
OCEB-136	□	13.6	25	60	95	16	0.2~0.4
OCEB-137	□	13.7	25	60	95	16	0.2~0.4
OCEB-138	□	13.8	25	60	95	16	0.2~0.4
OCEB-139	□	13.9	25	60	95	16	0.2~0.4
OCEB-140	●	14	25	60	95	16	0.2~0.4
OCEB-141	□	14.1	25	60	95	16	0.2~0.4
OCEB-142	□	14.2	25	60	95	16	0.2~0.4
OCEB-143	□	14.3	25	60	95	16	0.2~0.4
OCEB-144	□	14.4	25	60	95	16	0.2~0.4
OCEB-145	□	14.5	25	60	95	16	0.2~0.4
OCEB-146	□	14.6	25	60	95	16	0.2~0.4
OCEB-147	□	14.7	25	60	95	16	0.2~0.4
OCEB-148	□	14.8	25	60	95	16	0.2~0.4
OCEB-149	□	14.9	25	60	95	16	0.2~0.4
OCEB-150	●	15	25	60	95	16	0.2~0.4
OCEB-151	□	15.1	25	60	95	16	0.2~0.4
OCEB-152	□	15.2	25	60	95	16	0.2~0.4
OCEB-153	□	15.3	25	60	95	16	0.2~0.4
OCEB-154	□	15.4	25	60	95	16	0.2~0.4
OCEB-155	□	15.5	25	60	95	16	0.2~0.4
OCEB-156	□	15.6	25	60	95	16	0.2~0.4
OCEB-157	□	15.7	25	60	95	16	0.2~0.4
OCEB-158	□	15.8	25	60	95	16	0.2~0.4
OCEB-159	□	15.9	25	60	95	16	0.2~0.4
OCEB-160	●	16	25	60	95	16	0.2~0.4
OCEB-161	□	16.1	30	70	110	20	0.2~0.4
OCEB-162	□	16.2	30	70	110	20	0.2~0.4
OCEB-163	□	16.3	30	70	110	20	0.2~0.4
OCEB-164	□	16.4	30	70	110	20	0.2~0.4
OCEB-165	□	16.5	30	70	110	20	0.2~0.4
OCEB-166	□	16.6	30	70	110	20	0.2~0.4
OCEB-167	□	16.7	30	70	110	20	0.2~0.4
OCEB-168	□	16.8	30	70	110	20	0.2~0.4
OCEB-169	□	16.9	30	70	110	20	0.2~0.4
OCEB-170	●	17	30	70	110	20	0.2~0.4
OCEB-171	□	17.1	30	70	110	20	0.2~0.4
OCEB-172	□	17.2	30	70	110	20	0.2~0.4
OCEB-173	□	17.3	30	70	110	20	0.2~0.4
OCEB-174	□	17.4	30	70	110	20	0.2~0.4
OCEB-175	□	17.5	30	70	110	20	0.2~0.4
OCEB-176	□	17.6	30	70	110	20	0.2~0.4
OCEB-177	□	17.7	30	70	110	20	0.2~0.4
OCEB-178	□	17.8	30	70	110	20	0.2~0.4
OCEB-179	□	17.9	30	70	110	20	0.2~0.4
OCEB-180	●	18	30	70	110	20	0.2~0.4
OCEB-181	□	18.1	30	70	110	20	0.2~0.4



# 付け刃エンドミル

# OCEB形

(前ページの続き)

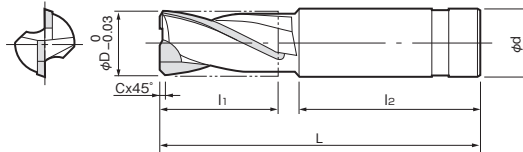

材質：超硬K種(鑄鉄用)

形番 Cat. No.	在庫 Stock	寸法 (mm) Dimensions (mm)					
		φD	l <sub>1</sub>	l <sub>2</sub>	L	φd	C
OCEB-182	□	18.2	30	70	110	20	0.2~0.4
OCEB-183	□	18.3	30	70	110	20	0.2~0.4
OCEB-184	□	18.4	30	70	110	20	0.2~0.4
OCEB-185	□	18.5	30	70	110	20	0.2~0.4
OCEB-186	□	18.6	30	70	110	20	0.2~0.4
OCEB-187	□	18.7	30	70	110	20	0.2~0.4
OCEB-188	□	18.8	30	70	110	20	0.2~0.4
OCEB-189	□	18.9	30	70	110	20	0.2~0.4
OCEB-190	●	19	30	70	110	20	0.2~0.4
OCEB-191	□	19.1	30	70	110	20	0.2~0.4
OCEB-192	□	19.2	30	70	110	20	0.2~0.4
OCEB-193	□	19.3	30	70	110	20	0.2~0.4
OCEB-194	□	19.4	30	70	110	20	0.2~0.4
OCEB-195	□	19.5	30	70	110	20	0.2~0.4
OCEB-196	□	19.6	30	70	110	20	0.3~0.6
OCEB-197	□	19.7	30	70	110	20	0.3~0.6
OCEB-198	□	19.8	30	70	110	20	0.3~0.6
OCEB-199	□	19.9	30	70	110	20	0.3~0.6
OCEB-200	●	20	30	70	110	20	0.3~0.6
OCEB-201	□	20.1	30	70	110	20	0.3~0.6
OCEB-202	□	20.2	30	70	110	20	0.3~0.6
OCEB-203	□	20.3	30	70	110	20	0.3~0.6
OCEB-204	□	20.4	30	70	110	20	0.3~0.6
OCEB-205	□	20.5	30	70	110	20	0.3~0.6
OCEB-206	□	20.6	30	70	110	20	0.3~0.6
OCEB-207	□	20.7	30	70	110	20	0.3~0.6
OCEB-208	□	20.8	30	70	110	20	0.3~0.6
OCEB-209	□	20.9	30	70	110	20	0.3~0.6
OCEB-210	●	21	30	70	110	20	0.3~0.6
OCEB-211	□	21.1	30	70	110	20	0.3~0.6
OCEB-212	□	21.2	30	70	110	20	0.3~0.6
OCEB-213	□	21.3	30	70	110	20	0.3~0.6
OCEB-214	□	21.4	30	70	110	20	0.3~0.6
OCEB-215	□	21.5	30	70	110	20	0.3~0.6
OCEB-216	□	21.6	30	70	110	20	0.3~0.6
OCEB-217	□	21.7	30	70	110	20	0.3~0.6
OCEB-218	□	21.8	30	70	110	20	0.3~0.6
OCEB-219	□	21.9	30	70	110	20	0.3~0.6
OCEB-220	●	22	30	70	110	20	0.3~0.6
OCEB-221	□	22.1	40	85	135	25	0.3~0.6
OCEB-222	□	22.2	40	85	135	25	0.3~0.6
OCEB-223	□	22.3	40	85	135	25	0.3~0.6
OCEB-224	□	22.4	40	85	135	25	0.3~0.6
OCEB-225	□	22.5	40	85	135	25	0.3~0.6
OCEB-226	□	22.6	40	85	135	25	0.3~0.6
OCEB-227	□	22.7	40	85	135	25	0.3~0.6
OCEB-228	□	22.8	40	85	135	25	0.3~0.6
OCEB-229	□	22.9	40	85	135	25	0.3~0.6
OCEB-230	●	23	40	85	135	25	0.3~0.6
OCEB-231	□	23.1	40	85	135	25	0.3~0.6
OCEB-232	□	23.2	40	85	135	25	0.3~0.6
OCEB-233	□	23.3	40	85	135	25	0.3~0.6
OCEB-234	□	23.4	40	85	135	25	0.3~0.6
OCEB-235	□	23.5	40	85	135	25	0.3~0.6
OCEB-236	□	23.6	40	85	135	25	0.3~0.6
OCEB-237	□	23.7	40	85	135	25	0.3~0.6
OCEB-238	□	23.8	40	85	135	25	0.3~0.6
OCEB-239	□	23.9	40	85	135	25	0.3~0.6
OCEB-240	●	24	40	85	135	25	0.3~0.6
OCEB-241	□	24.1	40	85	135	25	0.3~0.6
OCEB-242	□	24.2	40	85	135	25	0.3~0.6
OCEB-243	□	24.3	40	85	135	25	0.3~0.6
OCEB-244	□	24.4	40	85	135	25	0.3~0.6
OCEB-245	□	24.5	40	85	135	25	0.3~0.6
OCEB-246	□	24.6	40	85	135	25	0.3~0.6
OCEB-247	□	24.7	40	85	135	25	0.3~0.6
OCEB-248	□	24.8	40	85	135	25	0.3~0.6
OCEB-249	□	24.9	40	85	135	25	0.3~0.6
OCEB-250	●	25	40	85	135	25	0.3~0.6
OCEB-251	□	25.1	40	85	135	25	0.3~0.6
OCEB-252	□	25.2	40	85	135	25	0.3~0.6
OCEB-253	□	25.3	40	85	135	25	0.3~0.6
OCEB-254	□	25.4	40	85	135	25	0.3~0.6
OCEB-255	□	25.5	40	85	135	25	0.3~0.6
OCEB-256	□	25.6	40	85	135	25	0.3~0.6
OCEB-257	□	25.7	40	85	135	25	0.3~0.6
OCEB-258	□	25.8	40	85	135	25	0.3~0.6
OCEB-259	□	25.9	40	85	135	25	0.3~0.6
OCEB-260	●	26	40	85	135	25	0.3~0.6
OCEB-261	□	26.1	40	85	135	25	0.3~0.6
OCEB-262	□	26.2	40	85	135	25	0.3~0.6
OCEB-263	□	26.3	40	85	135	25	0.3~0.6

# 付け刃エンドミル

# OCEB形

(前ページの続き)

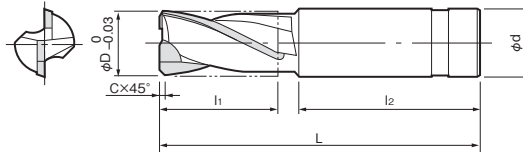

材質：超硬K種(鋳鉄用)

形番 Cat. No.	在庫 Stock	寸法 (mm) Dimensions (mm)					
		φD	l <sub>1</sub>	l <sub>2</sub>	L	φd	C
OCEB-264	□	26.4	40	85	135	25	0.3~0.6
OCEB-265	□	26.5	40	85	135	25	0.3~0.6
OCEB-266	□	26.6	40	85	135	25	0.3~0.6
OCEB-267	□	26.7	40	85	135	25	0.3~0.6
OCEB-268	□	26.8	40	85	135	25	0.3~0.6
OCEB-269	□	26.9	40	85	135	25	0.3~0.6
OCEB-270	●	27	40	85	135	25	0.3~0.6
OCEB-271	□	27.1	40	85	135	25	0.3~0.6
OCEB-272	□	27.2	40	85	135	25	0.3~0.6
OCEB-273	□	27.3	40	85	135	25	0.3~0.6
OCEB-274	□	27.4	40	85	135	25	0.3~0.6
OCEB-275	□	27.5	40	85	135	25	0.3~0.6
OCEB-276	□	27.6	40	85	135	25	0.3~0.6
OCEB-277	□	27.7	40	85	135	25	0.3~0.6
OCEB-278	□	27.8	40	85	135	25	0.3~0.6
OCEB-279	□	27.9	40	85	135	25	0.3~0.6
OCEB-280	●	28	40	85	135	25	0.3~0.6
OCEB-281	□	28.1	55	85	150	32	0.3~0.6
OCEB-282	□	28.2	55	85	150	32	0.3~0.6
OCEB-283	□	28.3	55	85	150	32	0.3~0.6
OCEB-284	□	28.4	55	85	150	32	0.3~0.6
OCEB-285	□	28.5	55	85	150	32	0.3~0.6
OCEB-286	□	28.6	55	85	150	32	0.3~0.6
OCEB-287	□	28.7	55	85	150	32	0.3~0.6
OCEB-288	□	28.8	55	85	150	32	0.3~0.6
OCEB-289	□	28.9	55	85	150	32	0.3~0.6
OCEB-290	●	29	55	85	150	32	0.3~0.6
OCEB-291	□	29.1	55	85	150	32	0.3~0.6
OCEB-292	□	29.2	55	85	150	32	0.3~0.6
OCEB-293	□	29.3	55	85	150	32	0.3~0.6
OCEB-294	□	29.4	55	85	150	32	0.3~0.6
OCEB-295	□	29.5	55	85	150	32	0.3~0.6
OCEB-296	□	29.6	55	85	150	32	0.3~0.6
OCEB-297	□	29.7	55	85	150	32	0.3~0.6
OCEB-298	□	29.8	55	85	150	32	0.3~0.6
OCEB-299	□	29.9	55	85	150	32	0.3~0.6
OCEB-300	●	30	55	85	150	32	0.3~0.6
OCEB-305	□	30.5	55	85	150	32	0.3~0.6
OCEB-310	●	31	55	85	150	32	0.3~0.6
OCEB-315	□	31.5	55	85	150	32	0.3~0.6
OCEB-320	●	32	55	85	150	32	0.3~0.6
OCEB-325	□	32.5	55	85	150	32	0.3~0.6
OCEB-330	●	33	55	85	150	32	0.3~0.6
OCEB-335	□	33.5	55	85	150	32	0.3~0.6
OCEB-340	●	34	55	85	150	32	0.3~0.6
OCEB-345	□	34.5	55	85	150	32	0.3~0.6
OCEB-350	●	35	55	85	150	32	0.3~0.6
OCEB-355	□	35.5	55	85	150	32	0.3~0.6
OCEB-360	●	36	55	85	150	32	0.3~0.6
OCEB-370	●	37	55	85	150	32	0.3~0.6
OCEB-380	●	38	55	85	150	32	0.3~0.6
OCEB-390	●	39	55	85	150	32	0.5~0.8
OCEB-400	●	40	65	85	160	32	0.5~0.8
OCEB-410	●	41	65	85	160	32	0.5~0.8
OCEB-420	●	42	65	85	160	32	0.5~0.8
OCEB-430	●	43	65	85	160	32	0.5~0.8
OCEB-440	●	44	65	85	160	32	0.5~0.8
OCEB-450	●	45	65	85	160	32	0.5~0.8
OCEB-460	●	46	65	85	160	32	0.5~0.8
OCEB-470	●	47	65	85	160	32	0.5~0.8
OCEB-480	●	48	65	85	160	32	0.5~0.8
OCEB-490	●	49	65	85	160	32	0.5~0.8
OCEB-500	●	50	65	85	160	32	0.5~0.8
OCEB-510	□	51	65	85	160	42	0.5~0.8
OCEB-520	□	52	65	85	160	42	0.5~0.8
OCEB-530	□	53	65	85	160	42	0.5~0.8
OCEB-540	□	54	65	85	160	42	0.5~0.8
OCEB-550	□	55	70	85	170	42	0.5~0.8
OCEB-560	□	56	70	85	170	42	0.5~0.8
OCEB-570	□	57	70	85	170	42	0.5~0.8
OCEB-580	□	58	70	85	170	42	0.5~0.8
OCEB-590	□	59	70	85	170	42	0.5~0.8
OCEB-600	□	60	70	85	170	42	0.5~0.8

## 付け刃エンドミル OCEB-S形

●2枚刃、鋼用、外周チップ継目なし



## 付け刃エンドミル OCEB-C形

●2枚刃、非鉄用、外周チップ継目なし

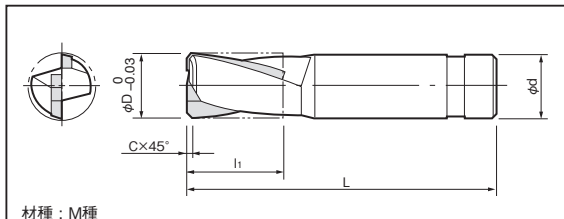

材種：M種

形番 Cat. No.	在庫 Stock	寸法 (mm) Dimensions (mm)				
		φD	li	L	φd	C
OCEB-S150	<input type="checkbox"/>	15	40	130	20	0.3~0.5
OCEB-S200	<input type="checkbox"/>	20	45	135	20	0.3~0.5
OCEB-S250	<input type="checkbox"/>	25	50	145	25	0.3~0.5
OCEB-S300	<input type="checkbox"/>	30	60	170	32	0.3~0.5
OCEB-S350	<input type="checkbox"/>	35	65	180	42	0.3~0.5
OCEB-S400	<input type="checkbox"/>	40	70	185	42	0.3~0.5
OCEB-S450	<input type="checkbox"/>	45	75	200	42	0.3~0.5
OCEB-S500	<input type="checkbox"/>	50	80	205	42	0.3~0.5

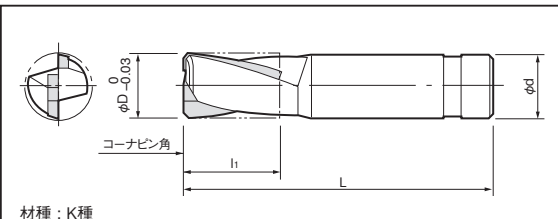

材種：K種

形番 Cat. No.	在庫 Stock	寸法 (mm) Dimensions (mm)				
		φD	li	L	φd	C
OCEB-C150	<input type="checkbox"/>	15	60	150	20	
OCEB-C200	<input type="checkbox"/>	20	80	170	20	
OCEB-C250	<input type="checkbox"/>	25	80	175	25	
OCEB-C300	<input type="checkbox"/>	30	100	210	32	
OCEB-C350	<input type="checkbox"/>	35	100	215	42	
OCEB-C400	<input type="checkbox"/>	40	100	215	42	
OCEB-C450	<input type="checkbox"/>	45	100	225	42	
OCEB-C500	<input type="checkbox"/>	50	100	225	42	

# ロングワンカットエンドミル(エキセントリックリリーフ形)

# OCL形

- 鋳鉄、非鉄金属用、2枚刃、中心刃付き、ねじれ角15°~25°

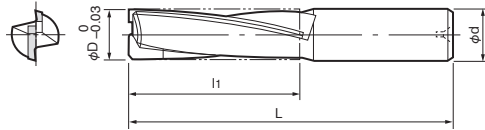

材種：K種超硬合金

形番 Cat. No.	在庫 Stock	寸法 (mm) Dimensions (mm)			
		φD	l1	L	φd
OCL 10×40-90	<input type="checkbox"/>	10	40	90	10
OCL 11×40-90	<input type="checkbox"/>	11	40	90	10
OCL 12×40-90	<input type="checkbox"/>	12	40	90	12
OCL 13×40-90	<input type="checkbox"/>	13	40	90	16
OCL 14×40-90	<input type="checkbox"/>	14	40	90	16
OCL 14×60-120	<input type="checkbox"/>	14	60	120	16
OCL 15×40-120	<input type="checkbox"/>	15	40	120	16
OCL 15×60-140	<input type="checkbox"/>	15	60	140	16
OCL 16×50-120	<input type="checkbox"/>	16	50	120	16
OCL 16×60-140	<input type="checkbox"/>	16	60	140	16
OCL 16×80-150	<input type="checkbox"/>	16	80	150	16
OCL 17×60-140	<input type="checkbox"/>	17	60	140	20
OCL 18×50-120	<input type="checkbox"/>	18	50	120	20
OCL 18×60-140	<input type="checkbox"/>	18	60	140	20
OCL 18×80-160	<input type="checkbox"/>	18	80	160	20
OCL 19×60-140	<input type="checkbox"/>	19	60	140	20
OCL 20×60-140	<input type="checkbox"/>	20	60	140	20
OCL 20×70-150	<input type="checkbox"/>	20	70	150	20
OCL 20×80-160	<input type="checkbox"/>	20	80	160	20
OCL 21×70-170	<input type="checkbox"/>	21	70	170	20
OCL 22×60-140	<input type="checkbox"/>	22	60	140	25
OCL 22×80-160	<input type="checkbox"/>	22	80	160	25
OCL 24×60-140	<input type="checkbox"/>	24	60	140	25
OCL 24×80-160	<input type="checkbox"/>	24	80	160	25
OCL 24×100-180	<input type="checkbox"/>	24	100	180	25
OCL 25×60-140	<input type="checkbox"/>	25	60	140	25
OCL 25×80-160	<input type="checkbox"/>	25	80	160	25
OCL 25×100-180	<input type="checkbox"/>	25	100	180	25
OCL 26×60-140	<input type="checkbox"/>	26	60	140	25
OCL 26×80-160	<input type="checkbox"/>	26	80	160	25
OCL 26×100-180	<input type="checkbox"/>	26	100	180	25
OCL 28×60-150	<input type="checkbox"/>	28	60	150	25
OCL 28×80-170	<input type="checkbox"/>	28	80	170	25
OCL 28×100-190	<input type="checkbox"/>	28	100	190	25
OCL 30×80-180	<input type="checkbox"/>	30	80	180	32
OCL 30×100-200	<input type="checkbox"/>	30	100	200	42
OCL 30×120-220	<input type="checkbox"/>	30	120	220	42
OCL 32×80-180	<input type="checkbox"/>	32	80	180	42
OCL 32×100-200	<input type="checkbox"/>	32	100	200	42
OCL 34×80-180	<input type="checkbox"/>	34	80	180	42
OCL 34×100-200	<input type="checkbox"/>	34	100	200	42
OCL 35×80-180	<input type="checkbox"/>	35	80	180	32
OCL 35×100-200	<input type="checkbox"/>	35	100	200	32
OCL 35×120-220	<input type="checkbox"/>	35	120	220	32
OCL 36×80-180	<input type="checkbox"/>	36	80	180	32
OCL 36×100-200	<input type="checkbox"/>	36	100	200	32
OCL 38×80-180	<input type="checkbox"/>	38	80	180	32
OCL 38×100-200	<input type="checkbox"/>	38	100	200	32
OCL 40×80-180	<input type="checkbox"/>	40	80	180	32
OCL 40×100-200	<input type="checkbox"/>	40	100	200	32
OCL 40×120-220	<input type="checkbox"/>	40	120	220	32
OCL 40×150-250	<input type="checkbox"/>	40	150	250	32
OCL 45×80-180	<input type="checkbox"/>	45	80	180	42
OCL 45×100-200	<input type="checkbox"/>	45	100	200	42
OCL 45×120-220	<input type="checkbox"/>	45	120	220	42
OCL 45×150-250	<input type="checkbox"/>	45	150	250	42
OCL 50×80-180	<input type="checkbox"/>	50	80	180	42
OCL 50×100-200	<input type="checkbox"/>	50	100	200	42
OCL 50×120-220	<input type="checkbox"/>	50	120	220	42
OCL 50×150-250	<input type="checkbox"/>	50	150	250	42

# ロングワンカットエンドミル

# OC-L形

● 鋳鉄、非鉄金属用、2枚刃、中心刃付き、  
ねじれ角15°~25°

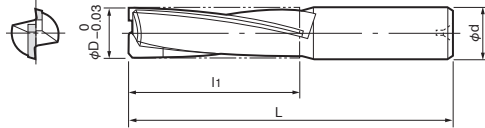

材種：K種超硬合金

形番 Cat. No.	在庫 Stock	寸法 (mm) Dimensions (mm)					形番 Cat. No.	在庫 Stock	寸法 (mm) Dimensions (mm)				
		φD	l1	L	φd				φD	l1	L	φd	
OC-L 10×30-90	<input type="checkbox"/>	10	30	90	12		OC-L 12.5×40-110	<input type="checkbox"/>	12.5	40	110	16	
OC-L 10×30-100	<input type="checkbox"/>	10	30	100	12		OC-L 12.5×40-120	<input type="checkbox"/>	12.5	40	120	16	
OC-L 10×40-100	<input type="checkbox"/>	10	40	100	12		OC-L 12.5×50-120	<input type="checkbox"/>	12.5	50	120	16	
OC-L 10×40-110	<input type="checkbox"/>	10	40	110	12		OC-L 12.5×50-130	<input type="checkbox"/>	12.5	50	130	16	
OC-L 10×50-110	<input type="checkbox"/>	10	50	110	12		OC-L 12.5×60-130	<input type="checkbox"/>	12.5	60	130	16	
OC-L 10×50-120	<input type="checkbox"/>	10	50	120	12		OC-L 12.5×60-140	<input type="checkbox"/>	12.5	60	140	16	
OC-L 10×60-120	<input type="checkbox"/>	10	60	120	12		OC-L 13×30-100	<input type="checkbox"/>	13	30	100	16	
OC-L 10×60-130	<input type="checkbox"/>	10	60	130	12		OC-L 13×30-110	<input type="checkbox"/>	13	30	110	16	
OC-L 10.5×30-90	<input type="checkbox"/>	10.5	30	90	12		OC-L 13×40-110	<input type="checkbox"/>	13	40	110	16	
OC-L 10.5×30-100	<input type="checkbox"/>	10.5	30	100	12		OC-L 13×40-120	<input type="checkbox"/>	13	40	120	16	
OC-L 10.5×40-100	<input type="checkbox"/>	10.5	40	100	12		OC-L 13×50-120	<input type="checkbox"/>	13	50	120	16	
OC-L 10.5×40-110	<input type="checkbox"/>	10.5	40	110	12		OC-L 13×50-130	<input type="checkbox"/>	13	50	130	16	
OC-L 10.5×50-110	<input type="checkbox"/>	10.5	50	110	12		OC-L 13×60-130	<input type="checkbox"/>	13	60	130	16	
OC-L 10.5×50-120	<input type="checkbox"/>	10.5	50	120	12		OC-L 13×60-140	<input type="checkbox"/>	13	60	140	16	
OC-L 10.5×60-120	<input type="checkbox"/>	10.5	60	120	12		OC-L 13.5×40-110	<input type="checkbox"/>	13.5	40	110	16	
OC-L 10.5×60-130	<input type="checkbox"/>	10.5	60	130	12		OC-L 13.5×40-120	<input type="checkbox"/>	13.5	40	120	16	
OC-L 11×30-90	<input type="checkbox"/>	11	30	90	12		OC-L 13.5×50-120	<input type="checkbox"/>	13.5	50	120	16	
OC-L 11×30-100	<input type="checkbox"/>	11	30	100	12		OC-L 13.5×50-130	<input type="checkbox"/>	13.5	50	130	16	
OC-L 11×40-100	<input type="checkbox"/>	11	40	100	12		OC-L 13.5×60-130	<input type="checkbox"/>	13.5	60	130	16	
OC-L 11×40-110	<input type="checkbox"/>	11	40	110	12		OC-L 13.5×60-140	<input type="checkbox"/>	13.5	60	140	16	
OC-L 11×50-110	<input type="checkbox"/>	11	50	110	12		OC-L 14×40-110	<input type="checkbox"/>	14	40	110	16	
OC-L 11×50-120	<input type="checkbox"/>	11	50	120	12		OC-L 14×40-120	<input type="checkbox"/>	14	40	120	16	
OC-L 11×60-120	<input type="checkbox"/>	11	60	120	12		OC-L 14×50-120	<input type="checkbox"/>	14	50	120	16	
OC-L 11×60-130	<input type="checkbox"/>	11	60	130	12		OC-L 14×50-130	<input type="checkbox"/>	14	50	130	16	
OC-L 11.5×30-90	<input type="checkbox"/>	11.5	30	90	12		OC-L 14×60-120	<input type="checkbox"/>	14	60	120	16	
OC-L 11.5×30-100	<input type="checkbox"/>	11.5	30	100	12		OC-L 14×60-140	<input type="checkbox"/>	14	60	140	16	
OC-L 11.5×40-100	<input type="checkbox"/>	11.5	40	100	12		OC-L 14×80-150	<input type="checkbox"/>	14	80	150	16	
OC-L 11.5×40-110	<input type="checkbox"/>	11.5	40	110	12		OC-L 14×80-160	<input type="checkbox"/>	14	80	160	16	
OC-L 11.5×50-110	<input type="checkbox"/>	11.5	50	110	12		OC-L 14.5×50-120	<input type="checkbox"/>	14.5	50	120	16	
OC-L 11.5×50-120	<input type="checkbox"/>	11.5	50	120	12		OC-L 14.5×50-130	<input type="checkbox"/>	14.5	50	130	16	
OC-L 11.5×60-120	<input type="checkbox"/>	11.5	60	120	12		OC-L 14.5×60-120	<input type="checkbox"/>	14.5	60	120	16	
OC-L 11.5×60-130	<input type="checkbox"/>	11.5	60	130	12		OC-L 14.5×60-140	<input type="checkbox"/>	14.5	60	140	16	
OC-L 12×30-90	<input type="checkbox"/>	12	30	90	12		OC-L 14.5×80-150	<input type="checkbox"/>	14.5	80	150	16	
OC-L 12×30-100	<input type="checkbox"/>	12	30	100	12		OC-L 14.5×80-160	<input type="checkbox"/>	14.5	80	160	16	
OC-L 12×40-100	<input type="checkbox"/>	12	40	100	12		OC-L 15×40-110	<input type="checkbox"/>	15	40	110	16	
OC-L 12×40-110	<input type="checkbox"/>	12	40	110	12		OC-L 15×40-120	<input type="checkbox"/>	15	40	120	16	
OC-L 12×50-110	<input type="checkbox"/>	12	50	110	12		OC-L 15×50-120	<input type="checkbox"/>	15	50	120	16	
OC-L 12×50-120	<input type="checkbox"/>	12	50	120	12		OC-L 15×50-130	<input type="checkbox"/>	15	50	130	16	
OC-L 12×60-120	<input type="checkbox"/>	12	60	120	12		OC-L 15×60-130	<input type="checkbox"/>	15	60	130	16	
OC-L 12.5×30-100	<input type="checkbox"/>	12.5	30	100	16		OC-L 15×60-140	<input type="checkbox"/>	15	60	140	16	
OC-L 12.5×30-110	<input type="checkbox"/>	12.5	30	110	16		OC-L 15×80-150	<input type="checkbox"/>	15	80	150	16	

## ロングワンカットエンドミル

## OC-L形

(前ページの続き)

形番 Cat. No.	在庫 Stock	寸法 (mm) Dimensions (mm)			
		φD	h <sub>i</sub>	L	φd
OC-L 15×80-160	□	15	80	160	16
OC-L 15.5×60-140	□	15.5	60	140	16
OC-L 15.5×80-160	□	15.5	80	160	16
OC-L 16×50-130	□	16	50	130	16
OC-L 16×60-140	□	16	60	140	16
OC-L 16×80-160	□	16	80	160	16
OC-L 16.5×60-140	□	16.5	60	140	16
OC-L 16.5×80-160	□	16.5	80	160	16
OC-L 17×60-140	□	17	60	140	20
OC-L 17×60-150	□	17	60	150	20
OC-L 17×80-160	□	17	80	160	20
OC-L 17×80-170	□	17	80	170	20
OC-L 17.5×60-140	□	17.5	60	140	20
OC-L 17.5×60-150	□	17.5	60	150	20
OC-L 17.5×80-160	□	17.5	80	160	20
OC-L 17.5×80-170	□	17.5	80	170	20
OC-L 18×50-130	□	18	50	130	20
OC-L 18×50-140	□	18	50	140	20
OC-L 18×60-140	□	18	60	140	20
OC-L 18×60-150	□	18	60	150	20
OC-L 18×80-160	□	18	80	160	20
OC-L 18×80-170	□	18	80	170	20
OC-L 18×100-180	□	18	100	180	20
OC-L 18×100-190	□	18	100	190	20
OC-L 18.5×60-150	□	18.5	60	150	20
OC-L 18.5×80-170	□	18.5	80	170	20
OC-L 19×50-130	□	19	50	130	20
OC-L 19×50-140	□	19	50	140	20
OC-L 19×60-140	□	19	60	140	20
OC-L 19×60-150	□	19	60	150	20
OC-L 19×80-160	□	19	80	160	20
OC-L 19×80-170	□	19	80	170	20
OC-L 19.5×60-140	□	19.5	60	140	20
OC-L 19.5×60-150	□	19.5	60	150	20
OC-L 19.5×80-160	□	19.5	80	160	20
OC-L 19.5×80-170	□	19.5	80	170	20
OC-L 20×60-140	□	20	60	140	20
OC-L 20×60-150	□	20	60	150	20
OC-L 20×80-160	□	20	80	160	20
OC-L 20×80-170	□	20	80	170	20
OC-L 20×100-180	□	20	100	180	20
OC-L 20×100-190	□	20	100	190	20
OC-L 20.5×60-150	□	20.5	60	150	20
OC-L 20.5×80-170	□	20.5	80	170	20
OC-L 20.5×100-190	□	20.5	100	190	20
OC-L 21×60-150	□	21	60	150	20
OC-L 21×80-170	□	21	80	170	20
OC-L 21×100-190	□	21	100	190	20
OC-L 21.5×60-150	□	21.5	60	150	20
OC-L 21.5×80-170	□	21.5	80	170	20
OC-L 21.5×100-190	□	21.5	100	190	20
OC-L 22×60-150	□	22	60	150	25
OC-L 22×60-155	□	22	60	155	25

形番 Cat. No.	在庫 Stock	寸法 (mm) Dimensions (mm)			
		φD	h <sub>i</sub>	L	φd
OC-L 22×80-170	□	22	80	170	25
OC-L 22×80-175	□	22	80	175	25
OC-L 22×100-190	□	22	100	190	25
OC-L 22×100-195	□	22	100	195	25
OC-L 22.5×60-150	□	22.5	60	150	25
OC-L 22.5×60-155	□	22.5	60	155	25
OC-L 22.5×80-170	□	22.5	80	170	25
OC-L 22.5×80-175	□	22.5	80	175	25
OC-L 22.5×100-190	□	22.5	100	190	25
OC-L 22.5×100-195	□	22.5	100	195	25
OC-L 23×60-150	□	23	60	150	25
OC-L 23×60-155	□	23	60	155	25
OC-L 23×80-170	□	23	80	170	25
OC-L 23×80-175	□	23	80	175	25
OC-L 23×100-190	□	23	100	190	25
OC-L 23×100-195	□	23	100	195	25
OC-L 23.5×60-150	□	23.5	60	150	25
OC-L 23.5×60-155	□	23.5	60	155	25
OC-L 23.5×80-170	□	23.5	80	170	25
OC-L 23.5×80-175	□	23.5	80	175	25
OC-L 24×60-150	□	24	60	150	25
OC-L 24×60-155	□	24	60	155	25
OC-L 24×80-170	□	24	80	170	25
OC-L 24×80-175	□	24	80	175	25
OC-L 24×100-190	□	24	100	190	25
OC-L 24×100-195	□	24	100	195	25
OC-L 24.5×60-150	□	24.5	60	150	25
OC-L 24.5×60-155	□	24.5	60	155	25
OC-L 24.5×80-170	□	24.5	80	170	25
OC-L 24.5×80-175	□	24.5	80	175	25
OC-L 24.5×100-190	□	24.5	100	190	25
OC-L 24.5×100-195	□	24.5	100	195	25
OC-L 25×60-150	□	25	60	150	25
OC-L 25×60-155	□	25	60	155	25
OC-L 25×80-170	□	25	80	170	25
OC-L 25×80-175	□	25	80	175	25
OC-L 25×100-190	□	25	100	190	25
OC-L 25×100-195	□	25	100	195	25
OC-L 25×120-210	□	25	120	210	25
OC-L 25×120-215	□	25	120	215	25
OC-L 25.5×60-150	□	25.5	60	150	25
OC-L 25.5×60-155	□	25.5	60	155	25
OC-L 25.5×80-170	□	25.5	80	170	25
OC-L 25.5×80-175	□	25.5	80	175	25
OC-L 25.5×100-190	□	25.5	100	190	25
OC-L 25.5×100-195	□	25.5	100	195	25
OC-L 26×60-150	□	26	60	150	25
OC-L 26×60-155	□	26	60	155	25
OC-L 26×80-170	□	26	80	170	25
OC-L 26×80-175	□	26	80	175	25
OC-L 26×100-190	□	26	100	190	25
OC-L 26×100-195	□	26	100	195	25
OC-L 26.5×80-170	□	26.5	80	170	25



OC-L形

ロングワンカットエンドミル

(前ページの続き)

形番 Cat. No.	在庫 Stock	寸法 (mm) Dimensions (mm)			
		φD	l <sub>1</sub>	L	φd
OC-L 26.5×80-175	□	26.5	80	175	25
OC-L 26.5×100-190	□	26.5	100	190	25
OC-L 26.5×100-195	□	26.5	100	195	25
OC-L 27×80-170	□	27	80	170	25
OC-L 27×80-175	□	27	80	175	25
OC-L 27×100-190	□	27	100	190	25
OC-L 27×100-195	□	27	100	195	25
OC-L 27.5×80-170	□	27.5	80	170	25
OC-L 27.5×80-175	□	27.5	80	175	25
OC-L 27.5×100-190	□	27.5	100	190	25
OC-L 27.5×100-195	□	27.5	100	195	25
OC-L 28×60-150	□	28	60	150	25
OC-L 28×60-155	□	28	60	155	25
OC-L 28×80-170	□	28	80	170	25
OC-L 28×80-175	□	28	80	175	25
OC-L 28×100-190	□	28	100	190	25
OC-L 28×100-195	□	28	100	195	25
OC-L 28.5×80-170	□	28.5	80	170	25
OC-L 28.5×80-175	□	28.5	80	175	25
OC-L 28.5×100-190	□	28.5	100	190	25
OC-L 28.5×100-195	□	28.5	100	195	25
OC-L 29×80-170	□	29	80	170	25
OC-L 29×80-175	□	29	80	175	25
OC-L 29×100-195	□	29	100	195	25
OC-L 29.5×80-170	□	29.5	80	170	32
OC-L 29.5×80-190	□	29.5	80	190	32
OC-L 29.5×100-190	□	29.5	100	190	32
OC-L 29.5×100-210	□	29.5	100	210	32
OC-L 30×60-150	□	30	60	150	32
OC-L 30×60-170	□	30	60	170	32
OC-L 30×80-170	□	30	80	170	32
OC-L 30×80-190	□	30	80	190	32
OC-L 30×100-190	□	30	100	190	32
OC-L 30×100-210	□	30	100	210	32
OC-L 30×120-210	□	30	120	210	32
OC-L 30×120-230	□	30	120	230	32
OC-L 30×150-240	□	30	150	240	32
OC-L 30×150-260	□	30	150	260	32
OC-L 31×100-200	□	31	100	200	32
OC-L 31×100-210	□	31	100	210	32
OC-L 31×120-220	□	31	120	220	32
OC-L 31×120-230	□	31	120	230	32
OC-L 32×80-180	□	32	80	180	32
OC-L 32×80-190	□	32	80	190	32
OC-L 32×100-200	□	32	100	200	32
OC-L 32×100-210	□	32	100	210	32
OC-L 32×120-220	□	32	120	220	32
OC-L 32×120-230	□	32	120	230	32
OC-L 32×150-250	□	32	150	250	32
OC-L 32×150-260	□	32	150	260	32
OC-L 33×100-200	□	33	100	200	32
OC-L 33×100-210	□	33	100	210	32
OC-L 33×120-220	□	33	120	220	32
OC-L 33×120-230	□	33	120	230	32

形番 Cat. No.	在庫 Stock	寸法 (mm) Dimensions (mm)			
		φD	l <sub>1</sub>	L	φd
OC-L 34×100-200	□	34	100	200	32
OC-L 34×100-210	□	34	100	210	32
OC-L 34×120-220	□	34	120	220	32
OC-L 34×120-230	□	34	120	230	32
OC-L 35×80-180	□	35	80	180	32
OC-L 35×80-190	□	35	80	190	32
OC-L 35×100-200	□	35	100	200	32
OC-L 35×100-210	□	35	100	210	32
OC-L 35×120-220	□	35	120	220	32
OC-L 35×120-230	□	35	120	230	32
OC-L 35×150-250	□	35	150	250	32
OC-L 35×150-260	□	35	150	260	32
OC-L 36×80-180	□	36	80	180	32
OC-L 36×80-190	□	36	80	190	32
OC-L 36×100-200	□	36	100	200	32
OC-L 36×100-210	□	36	100	210	32
OC-L 36×120-220	□	36	120	220	32
OC-L 36×120-230	□	36	120	230	32
OC-L 37×80-180	□	37	80	180	32
OC-L 37×80-190	□	37	80	190	32
OC-L 37×100-200	□	37	100	200	32
OC-L 37×100-210	□	37	100	210	32
OC-L 37×120-220	□	37	120	220	32
OC-L 37×120-230	□	37	120	230	32
OC-L 38×80-180	□	38	80	180	32
OC-L 38×80-190	□	38	80	190	32
OC-L 38×100-200	□	38	100	200	32
OC-L 38×100-210	□	38	100	210	32
OC-L 38×120-220	□	38	120	220	32
OC-L 38×120-230	□	38	120	230	32
OC-L 38×150-250	□	38	150	250	32
OC-L 38×150-260	□	38	150	260	32
OC-L 39×100-210	□	39	100	210	32
OC-L 39×120-230	□	39	120	230	32
OC-L 40×80-190	□	40	80	190	32
OC-L 40×100-210	□	40	100	210	32
OC-L 40×120-230	□	40	120	230	32
OC-L 40×150-260	□	40	150	260	32
OC-L 41×100-210	□	41	100	210	32
OC-L 41×150-260	□	41	150	260	32
OC-L 42×100-210	□	42	100	210	32
OC-L 42×150-260	□	42	150	260	32
OC-L 45×80-190	□	45	80	190	42
OC-L 45×80-205	□	45	80	205	42
OC-L 45×100-210	□	45	100	210	42
OC-L 45×100-225	□	45	100	225	42
OC-L 45×120-230	□	45	120	230	42
OC-L 45×120-245	□	45	120	245	42
OC-L 45×150-260	□	45	150	260	42
OC-L 45×150-275	□	45	150	275	42
OC-L 46×100-210	□	46	100	210	42
OC-L 46×100-225	□	46	100	225	42
OC-L 46×150-260	□	46	150	260	42
OC-L 46×150-275	□	46	150	275	42

## ロングワンカットエンドミル OC-L形

(前ページの続き)

形番 Cat. No.	在庫	寸法 (mm) Dimensions (mm)			
		φD	h	L	φd
OC-L 47×100-210	□	47	100	210	42
OC-L 47×100-225	□	47	100	225	42
OC-L 47×150-260	□	47	150	260	42
OC-L 47×150-275	□	47	150	275	42
OC-L 48×100-210	□	48	100	210	42
OC-L 48×100-225	□	48	100	225	42
OC-L 48×120-230	□	48	120	230	42
OC-L 48×120-245	□	48	120	245	42
OC-L 48×150-260	□	48	150	260	42
OC-L 48×150-275	□	48	150	275	42
OC-L 49×100-210	□	49	100	210	42
OC-L 49×100-225	□	49	100	225	42
OC-L 49×150-260	□	49	150	260	42
OC-L 49×150-275	□	49	150	275	42
OC-L 50×80-190	□	50	80	190	42
OC-L 50×80-205	□	50	80	205	42
OC-L 50×100-210	□	50	100	210	42
OC-L 50×100-225	□	50	100	225	42
OC-L 50×120-230	□	50	120	230	42
OC-L 50×120-245	□	50	120	245	42
OC-L 50×150-260	□	50	150	260	42
OC-L 50×150-275	□	50	150	275	42
OC-L 50×200-310	□	50	200	310	42
OC-L 50×200-325	□	50	200	325	42
OC-L 52×100-210	□	52	100	210	42
OC-L 52×100-225	□	52	100	225	42
OC-L 52×150-260	□	52	150	260	42
OC-L 52×150-275	□	52	150	275	42
OC-L 52×200-310	□	52	200	310	42
OC-L 52×200-325	□	52	200	325	42
OC-L 55×100-210	□	55	100	210	42
OC-L 55×100-225	□	55	100	225	42
OC-L 55×150-260	□	55	150	260	42
OC-L 55×150-275	□	55	150	275	42
OC-L 55×200-310	□	55	200	310	42
OC-L 55×200-325	□	55	200	325	42
OC-L 56×100-210	□	56	100	210	42
OC-L 56×100-225	□	56	100	225	42
OC-L 56×150-260	□	56	150	260	42
OC-L 56×150-275	□	56	150	275	42
OC-L 58×100-210	□	58	100	210	42
OC-L 58×100-225	□	58	100	225	42
OC-L 58×150-260	□	58	150	260	42
OC-L 58×150-275	□	58	150	275	42
OC-L 60×100-210	□	60	100	210	42
OC-L 60×100-225	□	60	100	225	42
OC-L 60×150-260	□	60	150	260	42
OC-L 60×150-275	□	60	150	275	42
OC-L 60×200-310	□	60	200	310	42
OC-L 60×200-325	□	60	200	325	42

55



# ロングワンカットエンドミル

# OC-L形

● 鋳鉄、非鉄金属用、2枚刃、中心刃付き、  
ねじれ角15°~25°

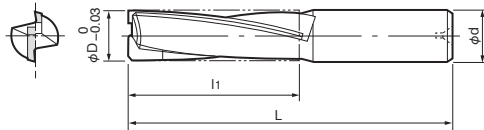

材種：K種超硬合金

形番 Cat. No.	在庫 Stock	寸法 (mm) Dimensions (mm)				形番 Cat. No.	在庫 Stock	寸法 (mm) Dimensions (mm)			
		φD	l <sub>1</sub>	L	φd			φD	l <sub>1</sub>	L	φd
OC-L-10030	□	10	30	84	12	OC-L-28060	□	28	60	157	32
OC-L-10040	□	10	40	94	12	OC-L-28080	□	28	80	177	32
OC-L-10060	□	10	60	114	12	OC-L-28100	□	28	100	197	32
OC-L-11030	□	11	30	84	12	OC-L-30060	□	30	60	157	32
OC-L-11060	□	11	60	114	12	OC-L-30070	□	30	70	167	32
OC-L-12030	□	12	30	84	12	OC-L-30100	□	30	100	197	32
OC-L-12040	□	12	40	94	12	OC-L-30120	□	30	120	217	32
OC-L-12060	□	12	60	114	12	OC-L-32070	□	32	70	167	32
OC-L-13030	□	13	30	94	16	OC-L-32100	□	32	100	197	32
OC-L-13040	□	13	40	104	16	OC-L-32120	□	32	120	217	32
OC-L-13060	□	13	60	124	16	OC-L-34070	□	34	70	167	32
OC-L-14040	□	14	40	105	16	OC-L-34100	□	34	100	197	32
OC-L-14050	□	14	50	115	16	OC-L-35070	□	35	70	167	32
OC-L-14060	□	14	60	125	16	OC-L-35100	□	35	100	197	32
OC-L-15040	□	15	40	105	16	OC-L-35120	□	35	120	217	32
OC-L-15050	□	15	50	115	16	OC-L-36060	□	36	60	156	32
OC-L-15060	□	15	60	125	16	OC-L-36070	□	36	70	167	32
OC-L-16050	□	16	50	115	16	OC-L-36100	□	36	100	197	32
OC-L-16080	□	16	80	145	16	OC-L-36120	□	36	120	217	32
OC-L-17050	□	17	50	126	20	OC-L-38070	□	38	70	167	32
OC-L-17060	□	17	60	136	20	OC-L-38100	□	38	100	197	32
OC-L-18050	□	18	50	126	20	OC-L-38120	□	38	120	217	32
OC-L-18060	□	18	60	136	20	OC-L-40080-S32	□	40	80	180	32
OC-L-18080	□	18	80	156	20	OC-L-40080-S42	□	40	80	190	42
OC-L-19050	□	19	50	126	20	OC-L-40120-S32	□	40	120	220	32
OC-L-19060	□	19	60	136	20	OC-L-40120-S42	□	40	120	230	42
OC-L-19080	□	19	80	156	20	OC-L-40150-S32	□	40	150	250	32
OC-L-20060	□	20	60	137	20	OC-L-40150-S42	□	40	150	250	42
OC-L-20070	□	20	70	147	20	OC-L-42080-S32	□	42	80	180	32
OC-L-20080	□	20	80	156	20	OC-L-42080-S42	□	42	80	190	42
OC-L-22060	□	22	60	147	25	OC-L-42120	□	42	120	230	42
OC-L-22080	□	22	80	167	25	OC-L-42150-S32	□	42	150	223	32
OC-L-22100	□	22	100	187	25	OC-L-42150-S42	□	42	150	260	42
OC-L-24060	□	24	60	147	25	OC-L-45080-S32	□	45	80	180	32
OC-L-24080	□	24	80	167	25	OC-L-45080-S42	□	45	80	190	42
OC-L-24100	□	24	100	187	25	OC-L-45120-S32	□	45	120	193	32
OC-L-25060	□	25	60	147	25	OC-L-45120-S42	□	45	120	230	42
OC-L-25080	□	25	80	167	25	OC-L-45150-S32	□	45	150	223	32
OC-L-25100	□	25	100	187	25	OC-L-45150-S42	□	45	150	260	42
OC-L-26060	□	26	60	157	32	OC-L-45200-S32	□	45	200	273	32
OC-L-26080	□	26	80	177	32	OC-L-45200-S42	□	45	200	310	42
OC-L-26100	□	26	100	197	32	OC-L-48080-S32	□	48	80	180	32



# ロングワンカットエンドミル

# OC-L形

● 鋳鉄、非鉄金属用、2枚刃、中心刃付き、  
ねじれ角15°~25°

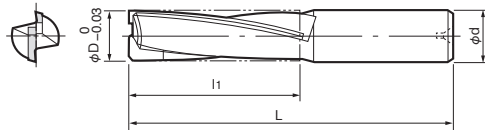

材種：K種超硬合金

形番 Cat. No.	在庫	寸法 (mm) Dimensions (mm)			
		φD	l1	L	φd
OCL 10x30	<input type="checkbox"/>	10.0	30	100	12
OCL 10x40	<input type="checkbox"/>	10.0	40	110	12
OCL 10x50	<input type="checkbox"/>	10.0	50	120	12
OCL 10x60	<input type="checkbox"/>	10.0	60	130	12
OCL 10.5x30	<input type="checkbox"/>	10.5	30	100	12
OCL 10.5x40	<input type="checkbox"/>	10.5	40	110	12
OCL 10.5x50	<input type="checkbox"/>	10.5	50	120	12
OCL 10.5x60	<input type="checkbox"/>	10.5	60	130	12
OCL 11x30	<input type="checkbox"/>	11.0	30	100	12
OCL 11x40	<input type="checkbox"/>	11.0	40	110	12
OCL 11x50	<input type="checkbox"/>	11.0	50	120	12
OCL 11x60	<input type="checkbox"/>	11.0	60	130	12
OCL 11.5x30	<input type="checkbox"/>	11.5	30	100	12
OCL 11.5x40	<input type="checkbox"/>	11.5	40	110	12
OCL 11.5x50	<input type="checkbox"/>	11.5	50	120	12
OCL 11.5x60	<input type="checkbox"/>	11.5	60	130	12
OCL 12x30	<input type="checkbox"/>	12.0	30	100	12
OCL 12x40	<input type="checkbox"/>	12.0	40	110	12
OCL 12x50	<input type="checkbox"/>	12.0	50	120	12
OCL 12x60	<input type="checkbox"/>	12.0	60	130	12
OCL 12.5x30	<input type="checkbox"/>	12.5	30	100	16
OCL 12.5x40	<input type="checkbox"/>	12.5	40	110	16
OCL 12.5x50	<input type="checkbox"/>	12.5	50	120	16
OCL 12.5x60	<input type="checkbox"/>	12.5	60	130	16
OCL 13x30	<input type="checkbox"/>	13.0	30	100	16
OCL 13x40	<input type="checkbox"/>	13.0	40	110	16
OCL 13x50	<input type="checkbox"/>	13.0	50	120	16
OCL 13x60	<input type="checkbox"/>	13.0	60	130	16
OCL 13.5x40	<input type="checkbox"/>	13.5	40	110	16
OCL 13.5x50	<input type="checkbox"/>	13.5	50	120	16
OCL 13.5x60	<input type="checkbox"/>	13.5	60	130	16
OCL 14x40	<input type="checkbox"/>	14.0	40	110	16
OCL 14x50	<input type="checkbox"/>	14.0	50	120	16
OCL 14x60	<input type="checkbox"/>	14.0	60	130	16
OCL 14x80	<input type="checkbox"/>	14.0	80	150	16
OCL 14.5x50	<input type="checkbox"/>	14.5	50	120	16
OCL 14.5x60	<input type="checkbox"/>	14.5	60	130	16
OCL 14.5x80	<input type="checkbox"/>	14.5	80	150	16
OCL 15x40	<input type="checkbox"/>	15.0	40	110	16
OCL 15x50	<input type="checkbox"/>	15.0	50	120	16
OCL 15x60	<input type="checkbox"/>	15.0	60	130	16
OCL 15x80	<input type="checkbox"/>	15.0	80	150	16
OCL 15.5x60	<input type="checkbox"/>	15.5	60	140	16
OCL 15.5x80	<input type="checkbox"/>	15.5	80	160	16
OCL 16x50	<input type="checkbox"/>	16.0	50	130	16
OCL 16x60	<input type="checkbox"/>	16.0	60	140	16
OCL 16x80	<input type="checkbox"/>	16.0	80	160	16
OCL 16.5x60	<input type="checkbox"/>	16.5	60	140	16
OCL 16.5x80	<input type="checkbox"/>	16.5	80	160	16
OCL 17x60	<input type="checkbox"/>	17.0	60	140	20
OCL 17x80	<input type="checkbox"/>	17.0	80	160	20
OCL 17.5x60	<input type="checkbox"/>	17.5	60	140	20
OCL 17.5x80	<input type="checkbox"/>	17.5	80	160	20
OCL 18x50	<input type="checkbox"/>	18.0	50	130	20
OCL 18x60	<input type="checkbox"/>	18.0	60	140	20
OCL 18x80	<input type="checkbox"/>	18.0	80	160	20
OCL 18x100	<input type="checkbox"/>	18.0	100	180	20
OCL 18.5x60	<input type="checkbox"/>	18.5	60	140	20
OCL 18.5x80	<input type="checkbox"/>	18.5	80	160	20
OCL 19x50	<input type="checkbox"/>	19.0	50	130	20
OCL 19x60	<input type="checkbox"/>	19.0	60	140	20
OCL 19x80	<input type="checkbox"/>	19.0	80	160	20
OCL 19.5x60	<input type="checkbox"/>	19.5	60	140	20
OCL 19.5x80	<input type="checkbox"/>	19.5	80	160	20
OCL 20x60	<input type="checkbox"/>	20.0	60	140	20
OCL 20x80	<input type="checkbox"/>	20.0	80	160	20
OCL 20x100	<input type="checkbox"/>	20.0	100	180	20
OCL 20.5x60	<input type="checkbox"/>	20.5	60	150	20
OCL 20.5x80	<input type="checkbox"/>	20.5	80	170	20
OCL 20.5x100	<input type="checkbox"/>	20.5	100	190	20
OCL 21x60	<input type="checkbox"/>	21.0	60	150	20
OCL 21x80	<input type="checkbox"/>	21.0	80	170	20
OCL 21x100	<input type="checkbox"/>	21.0	100	190	20
OCL 21.5x60	<input type="checkbox"/>	21.5	60	150	20
OCL 21.5x80	<input type="checkbox"/>	21.5	80	170	20
OCL 21.5x100	<input type="checkbox"/>	21.5	100	190	20
OCL 22x60	<input type="checkbox"/>	22.0	60	150	25
OCL 22x80	<input type="checkbox"/>	22.0	80	170	25
OCL 22x100	<input type="checkbox"/>	22.0	100	190	25
OCL 22.5x60	<input type="checkbox"/>	22.5	60	150	25
OCL 22.5x80	<input type="checkbox"/>	22.5	80	170	25
OCL 22.5x100	<input type="checkbox"/>	22.5	100	190	25
OCL 23x60	<input type="checkbox"/>	23.0	60	150	25
OCL 23x80	<input type="checkbox"/>	23.0	80	170	25

## ロングワンカットエンドミル

## OC-L形

(前ページの続き)

形番 Cat. No.	在庫 Stock	寸法 (mm) Dimensions (mm)			
		φD	l <sub>1</sub>	L	φd
OCL 23x100	<input type="checkbox"/>	23.0	100	190	25
OCL 23.5x60	<input type="checkbox"/>	23.5	60	150	25
OCL 23.5x80	<input type="checkbox"/>	23.5	80	170	25
OCL 24x60	<input type="checkbox"/>	24.0	60	150	25
OCL 24x80	<input type="checkbox"/>	24.0	80	170	25
OCL 24x100	<input type="checkbox"/>	24.0	100	190	25
OCL 24.5x60	<input type="checkbox"/>	24.5	60	150	25
OCL 24.5x80	<input type="checkbox"/>	24.5	80	170	25
OCL 24.5x100	<input type="checkbox"/>	24.5	100	190	25
OCL 25x60	<input type="checkbox"/>	25.0	60	150	25
OCL 25x80	<input type="checkbox"/>	25.0	80	170	25
OCL 25x100	<input type="checkbox"/>	25.0	100	190	25
OCL 25x120	<input type="checkbox"/>	25.0	120	210	25
OCL 25.5x60	<input type="checkbox"/>	25.5	60	150	25
OCL 25.5x80	<input type="checkbox"/>	25.5	80	170	25
OCL 25.5x100	<input type="checkbox"/>	25.5	100	190	25
OCL 26x60	<input type="checkbox"/>	26.0	60	150	25
OCL 26x80	<input type="checkbox"/>	26.0	80	170	25
OCL 26x100	<input type="checkbox"/>	26.0	100	190	25
OCL 26.5x80	<input type="checkbox"/>	26.5	80	170	25
OCL 26.5x100	<input type="checkbox"/>	26.5	100	190	25
OCL 27x80	<input type="checkbox"/>	27.0	80	170	25
OCL 27x100	<input type="checkbox"/>	27.0	100	190	25
OCL 27.5x80	<input type="checkbox"/>	27.5	80	170	25
OCL 27.5x100	<input type="checkbox"/>	27.5	100	190	25
OCL 28x60	<input type="checkbox"/>	28.0	60	150	25
OCL 28x80	<input type="checkbox"/>	28.0	80	170	25
OCL 28x100	<input type="checkbox"/>	28.0	100	190	25
OCL 28.5x80	<input type="checkbox"/>	28.5	80	170	25
OCL 28.5x100	<input type="checkbox"/>	28.5	100	190	25
OCL 29x80	<input type="checkbox"/>	29.0	80	170	25
OCL 29.5x80	<input type="checkbox"/>	29.5	80	170	32
OCL 29.5x100	<input type="checkbox"/>	29.5	100	190	32
OCL 30x60	<input type="checkbox"/>	30.0	60	150	32
OCL 30x80	<input type="checkbox"/>	30.0	80	170	32
OCL 30x100	<input type="checkbox"/>	30.0	100	190	32
OCL 30x120	<input type="checkbox"/>	30.0	120	210	32
OCL 30x150	<input type="checkbox"/>	30.0	150	240	32
OCL 31x100	<input type="checkbox"/>	31.0	100	200	32
OCL 31x120	<input type="checkbox"/>	31.0	120	220	32
OCL 32x80	<input type="checkbox"/>	32.0	80	180	32
OCL 32x100	<input type="checkbox"/>	32.0	100	200	32
OCL 32x120	<input type="checkbox"/>	32.0	120	220	32
OCL 32x150	<input type="checkbox"/>	32.0	150	250	32
OCL 33x100	<input type="checkbox"/>	33.0	100	200	32
OCL 33x120	<input type="checkbox"/>	33.0	120	220	32
OCL 34x100	<input type="checkbox"/>	34.0	100	200	32
OCL 34x120	<input type="checkbox"/>	34.0	120	220	32
OCL 35x80	<input type="checkbox"/>	35.0	80	180	32
OCL 35x100	<input type="checkbox"/>	35.0	100	200	32
OCL 35x120	<input type="checkbox"/>	35.0	120	220	32
OCL 35x150	<input type="checkbox"/>	35.0	150	250	32

形番 Cat. No.	在庫 Stock	寸法 (mm) Dimensions (mm)			
		φD	l <sub>1</sub>	L	φd
OCL 36x80	<input type="checkbox"/>	36.0	80	180	32
OCL 36x100	<input type="checkbox"/>	36.0	100	200	32
OCL 36x120	<input type="checkbox"/>	36.0	120	220	32
OCL 37x80	<input type="checkbox"/>	37.0	80	180	32
OCL 37x100	<input type="checkbox"/>	37.0	100	200	32
OCL 37x120	<input type="checkbox"/>	37.0	120	220	32
OCL 38x80	<input type="checkbox"/>	38.0	80	180	32
OCL 38x100	<input type="checkbox"/>	38.0	100	200	32
OCL 38x120	<input type="checkbox"/>	38.0	120	220	32
OCL 38x150	<input type="checkbox"/>	38.0	150	250	32
OCL 40x80	<input type="checkbox"/>	40.0	80	190	32
OCL 40x100	<input type="checkbox"/>	40.0	100	210	32
OCL 40x120	<input type="checkbox"/>	40.0	120	230	32
OCL 40x150	<input type="checkbox"/>	40.0	150	260	32
OCL 41x100	<input type="checkbox"/>	41.0	100	210	42
OCL 41x150	<input type="checkbox"/>	41.0	150	260	42
OCL 42x100	<input type="checkbox"/>	42.0	100	210	42
OCL 42x150	<input type="checkbox"/>	42.0	150	260	42
OCL 45x80	<input type="checkbox"/>	45.0	80	190	42
OCL 45x100	<input type="checkbox"/>	45.0	100	210	42
OCL 45x120	<input type="checkbox"/>	45.0	120	230	42
OCL 45x150	<input type="checkbox"/>	45.0	150	260	42
OCL 46x100	<input type="checkbox"/>	46.0	100	210	42
OCL 46x150	<input type="checkbox"/>	46.0	150	260	42
OCL 47x100	<input type="checkbox"/>	47.0	100	210	42
OCL 47x150	<input type="checkbox"/>	47.0	150	260	42
OCL 48x100	<input type="checkbox"/>	48.0	100	210	42
OCL 48x120	<input type="checkbox"/>	48.0	120	230	42
OCL 48x150	<input type="checkbox"/>	48.0	150	260	42
OCL 49x100	<input type="checkbox"/>	49.0	100	210	42
OCL 49x150	<input type="checkbox"/>	49.0	150	260	42
OCL 50x80	<input type="checkbox"/>	50.0	80	190	42
OCL 50x100	<input type="checkbox"/>	50.0	100	210	42
OCL 50x120	<input type="checkbox"/>	50.0	120	230	42
OCL 50x150	<input type="checkbox"/>	50.0	150	260	42
OCL 50x200	<input type="checkbox"/>	50.0	200	310	42
OCL 52x100	<input type="checkbox"/>	52.0	100	210	42
OCL 52x150	<input type="checkbox"/>	52.0	150	260	42
OCL 52x200	<input type="checkbox"/>	52.0	200	310	42
OCL 55x100	<input type="checkbox"/>	55.0	100	210	42
OCL 55x150	<input type="checkbox"/>	55.0	150	260	42
OCL 55x200	<input type="checkbox"/>	55.0	200	310	42
OCL 56x100	<input type="checkbox"/>	56.0	100	210	42
OCL 56x150	<input type="checkbox"/>	56.0	150	260	42
OCL 58x100	<input type="checkbox"/>	58.0	100	210	42
OCL 58x150	<input type="checkbox"/>	58.0	150	260	42
OCL 60x100	<input type="checkbox"/>	60.0	100	210	42
OCL 60x150	<input type="checkbox"/>	60.0	150	260	42
OCL 60x200	<input type="checkbox"/>	60.0	200	310	42

# スパイラルカットエンドミル

SPC形

●多刃

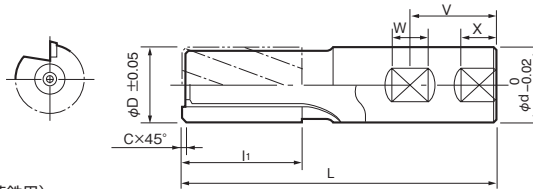
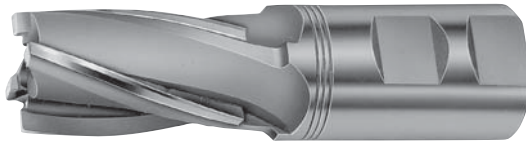

材質：超硬P種（鋼用）、超硬K種（鋳鉄用）

形番 Cat. No.	在庫 Stock	寸法 (mm) Dimensions (mm)					刃数 No. of flute
		φD	l <sub>1</sub>	L	φd	C	
SPC3-10	<input type="checkbox"/>	10	20	77	16	0.5	3
SPC3-11	<input type="checkbox"/>	11	20	77	16	0.5	3
SPC3-12	<input type="checkbox"/>	12	22	79	16	0.5	3
SPC3-13	<input type="checkbox"/>	13	22	79	16	0.5	3
SPC3-14	<input type="checkbox"/>	14	26	84	16	0.5	3
SPC4-15	<input type="checkbox"/>	15	26	84	16	0.5	4
SPC4-16	<input type="checkbox"/>	16	26	84	16	0.5	4
SPC4-17	<input type="checkbox"/>	17	26	84	16	0.5	4
SPC4-18	<input type="checkbox"/>	18	30	87	16	0.5	4
SPC4-19	<input type="checkbox"/>	19	30	87	16	0.5	4
SPC4-20	<input type="checkbox"/>	20	30	100	25	0.5	4
SPC4-21	<input type="checkbox"/>	21	30	100	25	0.5	4
SPC4-22	<input type="checkbox"/>	22	30	100	25	0.5	4
SPC4-23	<input type="checkbox"/>	23	40	107	25	0.5	4
SPC4-24	<input type="checkbox"/>	24	40	107	25	0.5	4
SPC4-25	<input type="checkbox"/>	25	40	107	25	0.5	4
SPC4-26	<input type="checkbox"/>	26	40	110	32	0.5	4
SPC4-27	<input type="checkbox"/>	27	40	110	32	0.5	4
SPC4-28	<input type="checkbox"/>	28	40	110	32	0.5	4
SPC4-29	<input type="checkbox"/>	29	50	118	32	0.5	4
SPC4-30	<input type="checkbox"/>	30	50	118	32	0.5	4
SPC6-31	<input type="checkbox"/>	31	50	118	32	0.5	6
SPC6-32	<input type="checkbox"/>	32	50	118	32	0.5	6
SPC6-33	<input type="checkbox"/>	33	50	118	32	0.5	6
SPC6-34	<input type="checkbox"/>	34	50	118	32	0.5	6
SPC6-35	<input type="checkbox"/>	35	50	118	32	0.5	6
SPC6-36	<input type="checkbox"/>	36	55	123	32	0.5	6
SPC6-37	<input type="checkbox"/>	37	55	123	32	0.5	6
SPC6-38	<input type="checkbox"/>	38	55	123	32	0.5	6
SPC6-39	<input type="checkbox"/>	39	55	123	32	0.5	6
SPC6-40	<input type="checkbox"/>	40	55	123	32	0.5	6
SPC6-42	<input type="checkbox"/>	42	60	128	32	0.5	6
SPC6-45	<input type="checkbox"/>	45	60	128	32	0.5	6
SPC6-48	<input type="checkbox"/>	48	60	128	32	0.5	6
SPC6-50	<input type="checkbox"/>	50	60	128	32	0.5	6

## ■シャンク寸法

寸法 (mm) Dimensions (mm)				
φd	柄長	V	W	X
16	48.4	24.2	10.16	—
25	57.9	29	13.08	12.7
32	57.6	29	13.08	12.7

# ハイスパイラルエンドミル

SPC形

● 鋳鉄用、4枚刃、6枚刃、ねじれ角10~25°

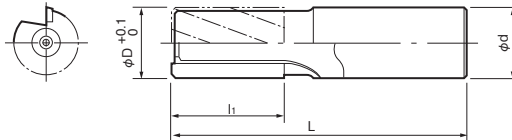

材種：超硬K種（鋳鉄用）

形番 Cat. No.	在庫 Stock	寸法 (mm) Dimensions (mm)				ねじれ角 No. of flute	刃数 No. of flute		形番 □□□□□□	在庫 □□□□	寸法 (□□) □□□□□□□□□□				ねじれ角	刃数 No. of flute	
		φD	li	L	φd						φD	li	L	φd			
SPC 8×20	□	8.0	□□	□□	10	10°	□			□□□□	□□	□□	□□	□□	□		
SPC 8.5×20	□	8.5	□□	□□	10	□□	□			□□□□	□□	□□	□□	□□	□		
SPC 9×20	□	9.0	□□	□□	10	□□	□			□□□□	□□	□□	□□	□□	□		
SPC 9.5×20	□	9.5	□□	□□	10	□□	□			□□□□	□□	□□	□□	□□	□		
SPC 10×20	□	10.0	□□	□□	10	□□	□			□□	□□	□□	□□	□□	□		
SPC 10.5×20	□	10.5	□□	□□	12	□□	□			□□	□□	□□	□□	□□	□		
SPC 11×20	□	11.0	□□	□□	12	□□	□			□□	□□	□□	□□	□□	□		
SPC 11.5×20	□	11.5	□□	□□	12	□□	□			□□	□□	□□	□□	□□	□		
SPC 12×20	□	12.0	□□	□□	12	□□	□			□□	□□	□□	□□	□□	□		
SPC 12.5×20	□	12.5	□□	□□	12	□□	□			□□	□□	□□	□□	□□	□		
SPC 13×20	□	13.0	□□	□□	12	□□	□			□□	□□	□□	□□	□□	□		
SPC 13.5×20	□	13.5	□□	□□	16	□□	□			□□	□□	□□	□□	□□	□		
SPC 14×20	□	14.0	□□	□□	16	□□	□			□□	□□	□□	□□	□□	□		
SPC 14.5×30	□	14.5	□□	□□	16	□□	□			□□	□□	□□	□□	□□	□		
SPC 15×30	□	15.0	□□	□□	16	□□	□			□□	□□	□□	□□	□□	□		
SPC 15.5×30	□	15.5	□□	□□	16	□□	□			□□	□□	□□	□□	□□	□		
SPC 16×30	□	16.0	□□	□□	16	□□	□			□□	□□	□□	□□	□□	□		
SPC 16.5×30	□	16.5	□□	□□	16	□□	□			□□	□□	□□	□□	□□	□		
SPC 17×30	□	17.0	□□	□□	16	□□	□			□□	□□	□□	□□	□□	□		
SPC 17.5×30	□	17.5	□□	□□	20	□□	□			□□	□□	□□	□□	□□	□		
SPC 18×30	□	18.0	□□	□□	20	□□	□			□□	□□	□□	□□	□□	□		
SPC 18.5×30	□	18.5	□□	□□	20	□□	□			□□	□□	□□	□□	□□	□		
SPC 19×30	□	19.0	□□	□□	20	□□	□			□□	□□	□□	□□	□□	□		
SPC 19.5×30	□	19.5	□□	□□	20	□□	□			□□	□□	□□	□□	□□	□		
SPC 20×30	□	20.0	□□	□□	20	□□	□			□□	□□	□□	□□	□□	□		
SPC 20.5×30	□	20.5	□□	□□	20	□□	□			□□	□□	□□	□□	□□	□		
SPC 21×30	□	21.0	□□	□□	20	□□	□			□□	□□	□□	□□	□□	□		
SPC 21.5×30	□	21.5	□□	□□	20	□□	□			□□	□□	□□	□□	□□	□		
SPC 22×30	□	22.0	□□	□□	20	□□	□			□□	□□	□□	□□	□□	□		
SPC 22.5×40	□	22.5	□□	□□	25	□□	□			□□	□□	□□	□□	□□	□		
SPC 23×40	□	23.0	□□	□□	25	□□	□			□□	□□	□□	□□	□□	□		
SPC 23.5×40	□	23.5	□□	□□	25	□□	□			□□	□□	□□	□□	□□	□		
SPC 24×40	□	24.0	□□	□□	25	□□	□			□□	□□	□□	□□	□□	□		
SPC 24.5×40	□	24.5	□□	□□	25	□□	□			□□	□□	□□	□□	□□	□		
SPC 25×40	□	25.0	□□	□□	25	□□	□			□□	□□	□□	□□	□□	□		
SPC 25.5×40	□	25.5	□□	□□	25	□□	□			□□	□□	□□	□□	□□	□		
SPC 26×40	□	26.0	□□	□□	25	□□	□			□□	□□	□□	□□	□□	□		
SPC 26.5×40	□	26.5	□□	□□	25	□□	□			□□	□□	□□	□□	□□	□		
SPC 27×40	□	27.0	□□	□□	25	□□	□			□□	□□	□□	□□	□□	□		
SPC 27.5×40	□	27.5	□□	□□	25	□□	□			□□	□□	□□	□□	□□	□		
SPC 28×40	□	28.0	□□	□□	25	□□	□			□□	□□	□□	□□	□□	□		

# SPC-L形

## ハイスパイラルエンドミル

● 鋳鉄用、4枚刃、6枚刃、ねじれ角15~25°  
エキセントリックリリーフ形

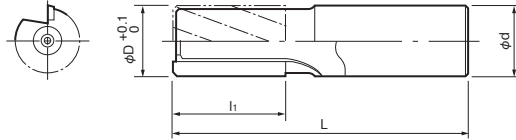

材質：超硬K種（鋳鉄用）

形番	在庫	寸法(□)				ねじれ角	刃数 No. of flute		形番	在庫	寸法(□)				ねじれ角	刃数 No. of flute	
		□□□□□□	φD	li	L						φd	□□□□□□	φD	li			
SPC-L 10×40-90	□	□□	□□	□□	□□	□□	□	SPC-L 22×80-160	□	□□	□□	□□□□	□□	□□	□		
SPC-L 10×60-110	□	□□	□□	□□□□	□□	□□	□	SPC-L 22×100-155	□	□□	□□□□	□□□□	□□	□□	□		
SPC-L 11×40-90	□	□□	□□	□□	□□	□□	□	SPC-L 22×120-175	□	□□	□□□□	□□□□	□□	□□	□		
SPC-L 12×40-90	□	□□	□□	□□	□□	□□	□	SPC-L 23×70-140	□	□□	□□	□□□□	□□	□□	□		
SPC-L 12×60-110	□	□□	□□	□□□□	□□	□□	□	SPC-L 24×60-140	□	□□	□□	□□□□	□□	□□	□		
SPC-L 13×40-90	□	□□	□□	□□	□□	□□	□	SPC-L 24×70-140	□	□□	□□	□□□□	□□	□□	□		
SPC-L 14×40-90	□	□□	□□	□□	□□	□□	□	SPC-L 24×80-160	□	□□	□□	□□□□	□□	□□	□		
SPC-L 14×60-110	□	□□	□□	□□□□	□□	□□	□	SPC-L 24×100-170	□	□□	□□□□	□□□□	□□	□□	□		
SPC-L 14×60-120	□	□□	□□	□□□□	□□	□□	□	SPC-L 24×100-180	□	□□	□□□□	□□□□	□□	□□	□		
SPC-L 15×40-120	□	□□	□□	□□□□	□□	□□	□	SPC-L 24×120-190	□	□□	□□□□	□□□□	□□	□□	□		
SPC-L 15×50-105	□	□□	□□	□□□□	□□	□□	□	SPC-L 25×60-140	□	□□	□□	□□□□	□□	□□	□		
SPC-L 15×60-115	□	□□	□□	□□□□	□□	□□	□	SPC-L 25×70-140	□	□□	□□	□□□□	□□	□□	□		
SPC-L 15×60-140	□	□□	□□	□□□□	□□	□□	□	SPC-L 25×80-160	□	□□	□□	□□□□	□□	□□	□		
SPC-L 15×80-135	□	□□	□□	□□□□	□□	□□	□	SPC-L 25×100-170	□	□□	□□□□	□□□□	□□	□□	□		
SPC-L 16×50-105	□	□□	□□	□□□□	□□	□□	□	SPC-L 25×100-180	□	□□	□□□□	□□□□	□□	□□	□		
SPC-L 16×50-120	□	□□	□□	□□□□	□□	□□	□	SPC-L 25×120-190	□	□□	□□□□	□□□□	□□	□□	□		
SPC-L 16×60-140	□	□□	□□	□□□□	□□	□□	□	SPC-L 25×150-220	□	□□	□□□□	□□□□	□□	□□	□		
SPC-L 16×80-135	□	□□	□□	□□□□	□□	□□	□	SPC-L 26×60-140	□	□□	□□	□□□□	□□	□□	□		
SPC-L 16×80-150	□	□□	□□	□□□□	□□	□□	□	SPC-L 26×70-140	□	□□	□□	□□□□	□□	□□	□		
SPC-L 17×50-105	□	□□	□□	□□□□	□□	□□	□	SPC-L 26×80-160	□	□□	□□	□□□□	□□	□□	□		
SPC-L 17×60-140	□	□□	□□	□□□□	□□	□□	□	SPC-L 26×100-170	□	□□	□□□□	□□□□	□□	□□	□		
SPC-L 18×50-105	□	□□	□□	□□□□	□□	□□	□	SPC-L 26×100-180	□	□□	□□	□□□□	□□	□□	□		
SPC-L 18×50-120	□	□□	□□	□□□□	□□	□□	□	SPC-L 26×120-190	□	□□	□□□□	□□□□	□□	□□	□		
SPC-L 18×60-140	□	□□	□□	□□□□	□□	□□	□	SPC-L 27×70-140	□	□□	□□	□□□□	□□	□□	□		
SPC-L 18×80-135	□	□□	□□	□□□□	□□	□□	□	SPC-L 28×60-150	□	□□	□□	□□□□	□□	□□	□		
SPC-L 18×80-160	□	□□	□□	□□□□	□□	□□	□	SPC-L 28×70-140	□	□□	□□	□□□□	□□	□□	□		
SPC-L 18×100-155	□	□□	□□□□	□□	□□	□□	□	SPC-L 28×80-170	□	□□	□□	□□□□	□□	□□	□		
SPC-L 19×50-105	□	□□	□□	□□□□	□□	□□	□	SPC-L 28×100-170	□	□□	□□□□	□□□□	□□	□□	□		
SPC-L 19×60-140	□	□□	□□	□□□□	□□	□□	□	SPC-L 28×100-190	□	□□	□□□□	□□□□	□□	□□	□		
SPC-L 20×50-105	□	□□	□□	□□□□	□□	□□	□	SPC-L 28×120-190	□	□□	□□□□	□□□□	□□	□□	□		
SPC-L 20×60-140	□	□□	□□	□□□□	□□	□□	□	SPC-L 29×70-140	□	□□	□□	□□□□	□□	□□	□		
SPC-L 20×70-150	□	□□	□□	□□□□	□□	□□	□	SPC-L 30×60-160	□	□□	□□	□□□□	□□	□□	□		
SPC-L 20×80-135	□	□□	□□	□□□□	□□	□□	□	SPC-L 30×70-140	□	□□	□□	□□□□	□□	□□	□		
SPC-L 20×80-160	□	□□	□□	□□□□	□□	□□	□	SPC-L 30×80-150	□	□□	□□	□□□□	□□	□□	□		
SPC-L 20×100-155	□	□□	□□□□	□□	□□	□□	□	SPC-L 30×80-180	□	□□	□□	□□□□	□□	□□	□		
SPC-L 20×120-175	□	□□	□□□□	□□	□□	□□	□	SPC-L 30×100-170	□	□□	□□	□□□□	□□	□□	□		
SPC-L 21×50-105	□	□□	□□	□□□□	□□	□□	□	SPC-L 30×100-200	□	□□	□□□□	□□□□	□□	□□	□		
SPC-L 21×70-170	□	□□	□□	□□□□	□□	□□	□	SPC-L 30×120-190	□	□□	□□□□	□□□□	□□	□□	□		
SPC-L 22×50-105	□	□□	□□	□□□□	□□	□□	□	SPC-L 30×120-220	□	□□	□□□□	□□□□	□□	□□	□		
SPC-L 22×60-140	□	□□	□□	□□□□	□□	□□	□	SPC-L 30×150-220	□	□□	□□□□	□□□□	□□	□□	□		
SPC-L 22×80-135	□	□□	□□	□□□□	□□	□□	□	SPC-L 30×150-250	□	□□	□□□□	□□□□	□□	□□	□		

□□□



# ハイスパイラルエンドミル

# SPC-L形

(前ページの続き)

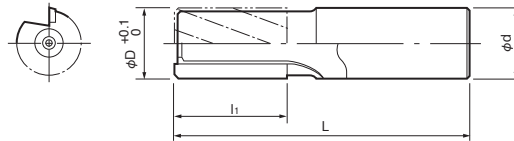

材質：超硬K種（鋳鉄用）

形番 Cat. No.	在庫 Stock	寸法 (mm) Dimensions (mm)				ねじれ角 No. of flute	刃数 No. of flute		形番 Cat. No.	在庫 Stock	寸法 (mm) Dimensions (mm)				ねじれ角 No. of flute	刃数 No. of flute	
		φD	li	L	φd						φD	li	L	φd			
SPC-L 31×80-160	□	31	80	160	32	25°	6		SPC-L 42×100-195	□	42	100	195	42	25°	6	
SPC-L 32×80-160	□	32	80	160	32	25°	6		SPC-L 42×120-215	□	42	120	215	42	25°	6	
SPC-L 32×80-180	□	32	80	180	32	25°	6		SPC-L 42×150-245	□	42	150	245	42	25°	6	
SPC-L 32×100-180	□	32	100	180	32	25°	6		SPC-L 43×100-180	□	43	100	180	42	25°	6	
SPC-L 32×100-200	□	32	100	200	32	25°	6		SPC-L 44×100-180	□	44	100	180	42	25°	6	
SPC-L 32×120-200	□	32	120	200	32	25°	6		SPC-L 45×80-175	□	45	80	175	42	25°	6	
SPC-L 32×150-230	□	32	150	230	32	25°	6		SPC-L 45×80-180	□	45	80	180	42	25°	6	
SPC-L 33×80-160	□	33	80	160	32	25°	6		SPC-L 45×100-195	□	45	100	195	42	25°	6	
SPC-L 34×80-160	□	34	80	160	32	25°	6		SPC-L 45×100-200	□	45	100	200	42	25°	6	
SPC-L 34×80-180	□	34	80	180	32	25°	6		SPC-L 45×120-215	□	45	120	215	42	25°	6	
SPC-L 34×100-200	□	34	100	200	32	25°	6		SPC-L 45×120-220	□	45	120	220	42	25°	6	
SPC-L 35×80-160	□	35	80	160	32	25°	6		SPC-L 45×150-245	□	45	150	245	42	25°	6	
SPC-L 35×80-180	□	35	80	180	32	25°	6		SPC-L 45×150-250	□	45	150	250	42	25°	6	
SPC-L 35×100-180	□	35	100	180	32	25°	6		SPC-L 45×200-295	□	45	200	295	42	25°	6	
SPC-L 35×100-200	□	35	100	200	32	25°	6		SPC-L 46×100-195	□	46	100	195	42	25°	6	
SPC-L 35×120-200	□	35	120	200	32	25°	6		SPC-L 46×120-215	□	46	120	215	42	25°	6	
SPC-L 35×120-220	□	35	120	220	32	25°	6		SPC-L 46×150-245	□	46	150	245	42	25°	6	
SPC-L 35×150-230	□	35	150	230	32	25°	6		SPC-L 47×100-180	□	47	100	180	42	25°	6	
SPC-L 36×80-160	□	36	80	160	32	25°	6		SPC-L 48×100-195	□	48	100	195	42	25°	6	
SPC-L 36×80-180	□	36	80	180	32	25°	6		SPC-L 48×120-215	□	48	120	215	42	25°	6	
SPC-L 36×100-180	□	36	100	180	32	25°	6		SPC-L 48×150-245	□	48	150	245	42	25°	6	
SPC-L 36×100-200	□	36	100	200	32	25°	6		SPC-L 48×200-295	□	48	200	295	42	25°	6	
SPC-L 36×120-200	□	36	120	200	32	25°	6		SPC-L 49×100-180	□	49	100	180	42	25°	6	
SPC-L 36×150-230	□	36	150	230	32	25°	6		SPC-L 50×80-175	□	50	80	175	42	25°	6	
SPC-L 37×80-160	□	37	80	160	32	25°	6		SPC-L 50×80-180	□	50	80	180	42	25°	6	
SPC-L 38×80-160	□	38	80	160	32	25°	6		SPC-L 50×100-195	□	50	100	195	42	25°	6	
SPC-L 38×80-180	□	38	80	180	32	25°	6		SPC-L 50×100-200	□	50	100	200	42	25°	6	
SPC-L 38×100-180	□	38	100	180	32	25°	6		SPC-L 50×120-215	□	50	120	215	42	25°	6	
SPC-L 38×100-200	□	38	100	200	32	25°	6		SPC-L 50×120-220	□	50	120	220	42	25°	6	
SPC-L 38×120-200	□	38	120	200	32	25°	6		SPC-L 50×150-245	□	50	150	245	42	25°	6	
SPC-L 38×150-230	□	38	150	230	32	25°	6		SPC-L 50×150-250	□	50	150	250	42	25°	6	
SPC-L 39×80-160	□	39	80	160	32	25°	6		SPC-L 50×200-295	□	50	200	295	42	25°	6	
SPC-L 40×80-175	□	40	80	175	42	25°	6		SPC-L 50×250-350	□	50	250	350	42	25°	6	
SPC-L 40×80-180	□	40	80	180	32	25°	6		SPC-L 55×100-195	□	55	100	195	42	25°	6	
SPC-L 40×100-195	□	40	100	195	42	25°	6		SPC-L 55×120-215	□	55	120	215	42	25°	6	
SPC-L 40×100-200	□	40	100	200	32	25°	6		SPC-L 55×150-245	□	55	150	245	42	25°	6	
SPC-L 40×120-215	□	40	120	215	42	25°	6		SPC-L 55×200-295	□	55	200	295	42	25°	6	
SPC-L 40×120-220	□	40	120	220	32	25°	6		SPC-L 60×100-195	□	60	100	195	42	25°	6	
SPC-L 40×150-245	□	40	150	245	42	25°	6		SPC-L 60×120-215	□	60	120	215	42	25°	6	
SPC-L 40×150-250	□	40	150	250	32	25°	6		SPC-L 60×150-245	□	60	150	245	42	25°	6	
SPC-L 40×200-295	□	40	200	295	42	25°	6		SPC-L 60×200-295	□	60	200	295	42	25°	6	
SPC-L 41×100-180	□	41	100	180	42	25°	6		SPC-L 60×250-350	□	60	250	350	42	25°	6	

# スパイラルカットエンドミル

# SPC-L形

●ロング刃

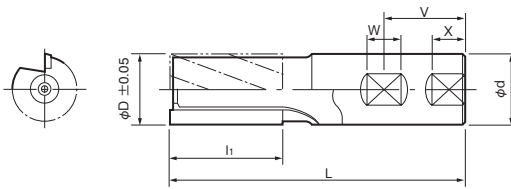

材種：K種（鋳鉄用）、M種（鋼用）

形番 Cat. No.	在庫 Stock		寸法 (mm) Dimensions (mm)				
	K	M	φD	Li	L	φd	刃数
SPC3-100L	<input type="checkbox"/>	<input type="checkbox"/>	10	40	110	16	3
SPC3-110L	<input type="checkbox"/>	<input type="checkbox"/>	11	40	110	16	3
SPC3-120L	<input type="checkbox"/>	<input type="checkbox"/>	12	40	110	16	3
SPC3-130L	<input type="checkbox"/>	<input type="checkbox"/>	13	40	110	16	3
SPC3-140L	<input type="checkbox"/>	<input type="checkbox"/>	14	45	125	16	3
SPC4-150L	<input type="checkbox"/>	<input type="checkbox"/>	15	45	125	16	4
SPC4-160L	<input type="checkbox"/>	<input type="checkbox"/>	16	45	125	16	4
SPC4-170L	<input type="checkbox"/>	<input type="checkbox"/>	17	45	125	20	4
SPC4-180L	<input type="checkbox"/>	<input type="checkbox"/>	18	45	125	20	4
SPC4-190L	<input type="checkbox"/>	<input type="checkbox"/>	19	55	145	20	4
SPC4-200L	<input type="checkbox"/>	<input type="checkbox"/>	20	55	145	20	4
SPC4-220L	<input type="checkbox"/>	<input type="checkbox"/>	22	55	145	25	4
SPC4-240L	<input type="checkbox"/>	<input type="checkbox"/>	24	65	160	25	4
SPC4-250L	<input type="checkbox"/>	<input type="checkbox"/>	25	65	160	25	4
SPC4-260L	<input type="checkbox"/>	<input type="checkbox"/>	26	65	160	32	4
SPC4-280L	<input type="checkbox"/>	<input type="checkbox"/>	28	75	170	32	4
SPC4-300L	<input type="checkbox"/>	<input type="checkbox"/>	30	75	175	32	4
SPC6-320L	<input type="checkbox"/>	<input type="checkbox"/>	32	75	175	32	6
SPC6-350L	<input type="checkbox"/>	<input type="checkbox"/>	35	75	175	32	6
SPC6-380L	<input type="checkbox"/>	<input type="checkbox"/>	38	80	190	32	6
SPC6-400L	<input type="checkbox"/>	<input type="checkbox"/>	40	100	210	32	6
SPC6-450L	<input type="checkbox"/>	<input type="checkbox"/>	45	120	230	32	6
SPC6-500L	<input type="checkbox"/>	<input type="checkbox"/>	50	120	230	32	6

## SPC-L形のシャンク寸法

φd	柄長	V	W	X
16	48.4	24.2	10.16	—
25	57.9	29.0	13.08	12.7
32	57.9	29.0	13.08	12.7

## ハイスパイラル エンドミル HSP4-EL形

- 多刃、スパイラルカットエンドミル  
超ロング刃、ストレートシャンク  
4枚刃、ねじれ角30°、铸铁用



## ハイスパイラル エンドミル HSP6-LT形

- 多刃、スパイラルカットエンドミル  
超ロング刃、テーパシャンク  
6枚刃、ねじれ角30°、铸铁用

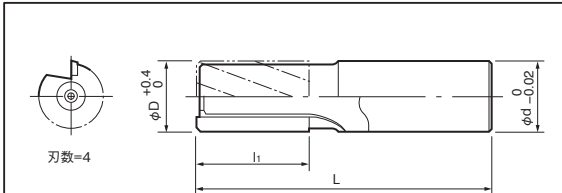

材種：超硬K種（铸铁用）

形番 Cat. No.	在庫 Stock	寸法 (mm) Dimensions (mm)			
		φD	l <sub>1</sub>	L	φd
HSP4-20075EL	<input type="checkbox"/>	20	75	175	20
HSP4-25050EL	<input type="checkbox"/>	25	50	150	25
HSP4-25075EL	<input type="checkbox"/>	25	75	175	25
HSP4-25090EL	<input type="checkbox"/>	25	90	190	25
HSP4-30050EL	<input type="checkbox"/>	30	50	150	32
HSP4-30075EL	<input type="checkbox"/>	30	75	175	32
HSP4-30100EL	<input type="checkbox"/>	30	100	200	32
HSP4-30120EL	<input type="checkbox"/>	30	120	220	32
HSP4-30150EL	<input type="checkbox"/>	30	150	250	32
HSP4-35120EL	<input type="checkbox"/>	35	120	220	32
HSP4-35150EL	<input type="checkbox"/>	35	150	250	32
HSP4-40050EL	<input type="checkbox"/>	40	50	150	42
HSP4-40080EL	<input type="checkbox"/>	40	80	180	42
HSP4-40100EL	<input type="checkbox"/>	40	100	200	42
HSP4-40120EL	<input type="checkbox"/>	40	120	220	42
HSP4-40155EL	<input type="checkbox"/>	40	155	250	42
HSP4-40205EL	<input type="checkbox"/>	40	205	300	42
HSP4-50055EL	<input type="checkbox"/>	50	55	145	42
HSP4-50205EL	<input type="checkbox"/>	50	205	305	42
HSP4-50255EL	<input type="checkbox"/>	50	255	355	42

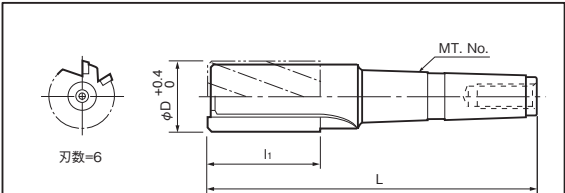

材種：超硬K種（铸铁用）

形番 Cat. No.	在庫 Stock	寸法 (mm) Dimensions (mm)			シャンク MT.No.	引ネジ
		φD	l <sub>1</sub>	L		
HSP6-50155LT	<input type="checkbox"/>	50	155	315	MT5	M20
HSP6-50205LT	<input type="checkbox"/>	50	205	365	MT5	M20
HSP6-50255LT	<input type="checkbox"/>	50	255	410	MT5	M20
HSP6-60255LT	<input type="checkbox"/>	60	255	415	MT5	M20
HSP6-60305LT	<input type="checkbox"/>	60	305	465	MT5	M20

# スロッチングエンドミル DT-MT形

●2枚刃、直刃、モールステーバシャンク

# スロッチングエンドミル DT-MT形

●2枚刃、直刃、モールステーバシャンク

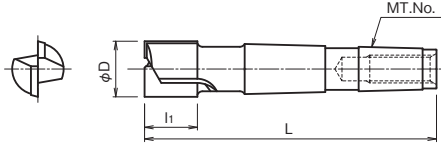

材種：K種

形番	在庫	寸法 (mm)			
		φD	l <sub>1</sub>	L	MT.No.
DT-050×MT1	<input type="checkbox"/>	5	8	74	MT1
DT-060×MT1	<input type="checkbox"/>	6	8	75	MT1
DT-070×MT1	<input type="checkbox"/>	7	10	78	MT1
DT-080×MT1	<input type="checkbox"/>	8	10	78	MT1
DT-090×MT1	<input type="checkbox"/>	9	13	80	MT1
DT-100×MT1	<input type="checkbox"/>	10	13	80	MT1
DT-110×MT1	<input type="checkbox"/>	11	16	85	MT1
DT-120×MT1	<input type="checkbox"/>	12	16	85	MT1
DT-130×MT1	<input type="checkbox"/>	13	16	85	MT1
DT-140×MT1	<input type="checkbox"/>	14	16	85	MT1
DT-140×MT2	<input type="checkbox"/>	14	16	100	MT2
DT-150×MT1	<input type="checkbox"/>	15	19	90	MT1
DT-150×MT2	<input type="checkbox"/>	15	19	100	MT2
DT-160×MT2	<input type="checkbox"/>	16	19	100	MT2
DT-170×MT2	<input type="checkbox"/>	17	19	100	MT2
DT-180×MT2	<input type="checkbox"/>	18	19	100	MT2
DT-190×MT2	<input type="checkbox"/>	19	19	105	MT2
DT-200×MT2	<input type="checkbox"/>	20	19	105	MT2
DT-210×MT2	<input type="checkbox"/>	21	19	105	MT2
DT-220×MT2	<input type="checkbox"/>	22	19	105	MT2
DT-220×MT3	<input type="checkbox"/>	22	19	120	MT3
DT-230×MT2	<input type="checkbox"/>	23	25	114	MT2
DT-230×MT3	<input type="checkbox"/>	23	25	130	MT3
DT-240×MT2	<input type="checkbox"/>	24	25	114	MT2
DT-240×MT3	<input type="checkbox"/>	24	25	130	MT3
DT-250×MT2	<input type="checkbox"/>	25	25	114	MT2
DT-250×MT3	<input type="checkbox"/>	25	25	130	MT3
DT-260×MT3	<input type="checkbox"/>	26	25	130	MT3
DT-270×MT3	<input type="checkbox"/>	27	25	130	MT3
DT-280×MT3	<input type="checkbox"/>	28	25	130	MT3
DT-290×MT3	<input type="checkbox"/>	29	25	135	MT3
DT-300×MT3	<input type="checkbox"/>	30	25	135	MT3
DT-310×MT3	<input type="checkbox"/>	31	25	135	MT3
DT-320×MT3	<input type="checkbox"/>	32	25	135	MT3
DT-330×MT3	<input type="checkbox"/>	33	30	165	MT3
DT-330×MT4	<input type="checkbox"/>	33	30	165	MT4
DT-340×MT3	<input type="checkbox"/>	34	30	145	MT3
DT-340×MT4	<input type="checkbox"/>	34	30	165	MT4
DT-350×MT3	<input type="checkbox"/>	35	30	142	MT3
DT-350×MT4	<input type="checkbox"/>	35	30	165	MT4
DT-360×MT4	<input type="checkbox"/>	36	30	165	MT4
DT-370×MT4	<input type="checkbox"/>	37	30	165	MT4
DT-380×MT3	<input type="checkbox"/>	38	30	142	MT3
DT-380×MT4	<input type="checkbox"/>	38	30	165	MT4
DT-390×MT4	<input type="checkbox"/>	39	30	165	MT4
DT-400×MT4	<input type="checkbox"/>	40	30	165	MT4
DT-410×MT4	<input type="checkbox"/>	41	35	170	MT4
DT-420×MT4	<input type="checkbox"/>	42	35	170	MT4
DT-430×MT4	<input type="checkbox"/>	43	35	170	MT4
DT-440×MT4	<input type="checkbox"/>	44	35	170	MT4
DT-450×MT4	<input type="checkbox"/>	45	35	170	MT4
DT-460×MT4	<input type="checkbox"/>	46	35	170	MT4
DT-470×MT4	<input type="checkbox"/>	47	35	170	MT4
DT-480×MT4	<input type="checkbox"/>	48	35	170	MT4
DT-490×MT4	<input type="checkbox"/>	49	35	170	MT4
DT-500×MT4	<input type="checkbox"/>	50	35	170	MT4
DT-520×MT4	<input type="checkbox"/>	52	40	170	MT4
DT-550×MT4	<input type="checkbox"/>	55	40	170	MT4
DT-550×MT5	<input type="checkbox"/>	55	40	202	MT5
DT-600×MT4	<input type="checkbox"/>	60	60	170	MT4
DT-600×MT5	<input type="checkbox"/>	60	60	223	MT5

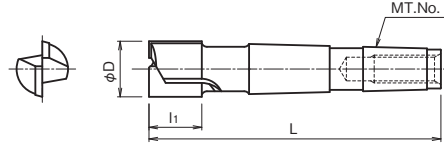

材種：M種

形番	在庫	寸法 (mm)			
		φD	l <sub>1</sub>	L	MT.No.
DT-050×MT1	<input type="checkbox"/>	5	8	74	MT1
DT-060×MT1	<input type="checkbox"/>	6	8	75	MT1
DT-070×MT1	<input type="checkbox"/>	7	10	78	MT1
DT-080×MT1	<input type="checkbox"/>	8	10	78	MT1
DT-090×MT1	<input type="checkbox"/>	9	13	80	MT1
DT-100×MT1	<input type="checkbox"/>	10	13	80	MT1
DT-110×MT1	<input type="checkbox"/>	11	16	85	MT1
DT-120×MT1	<input type="checkbox"/>	12	16	85	MT1
DT-130×MT1	<input type="checkbox"/>	13	16	85	MT1
DT-140×MT2	<input type="checkbox"/>	14	16	100	MT2
DT-150×MT1	<input type="checkbox"/>	15	19	90	MT1
DT-150×MT2	<input type="checkbox"/>	15	19	100	MT2
DT-160×MT2	<input type="checkbox"/>	16	19	100	MT2
DT-170×MT2	<input type="checkbox"/>	17	19	100	MT2
DT-180×MT2	<input type="checkbox"/>	18	19	100	MT2
DT-190×MT2	<input type="checkbox"/>	19	19	105	MT2
DT-200×MT2	<input type="checkbox"/>	20	19	105	MT2
DT-210×MT2	<input type="checkbox"/>	21	19	105	MT2
DT-220×MT2	<input type="checkbox"/>	22	19	105	MT2
DT-220×MT3	<input type="checkbox"/>	22	19	120	MT3
DT-230×MT2	<input type="checkbox"/>	23	25	114	MT2
DT-240×MT3	<input type="checkbox"/>	24	25	130	MT3
DT-250×MT2	<input type="checkbox"/>	25	25	114	MT2
DT-250×MT3	<input type="checkbox"/>	25	25	130	MT3
DT-260×MT3	<input type="checkbox"/>	26	25	130	MT3
DT-270×MT3	<input type="checkbox"/>	27	25	130	MT3
DT-280×MT3	<input type="checkbox"/>	28	25	130	MT3
DT-290×MT3	<input type="checkbox"/>	29	25	135	MT3
DT-300×MT3	<input type="checkbox"/>	30	25	135	MT3
DT-310×MT3	<input type="checkbox"/>	31	25	135	MT3
DT-320×MT3	<input type="checkbox"/>	32	25	135	MT3
DT-330×MT4	<input type="checkbox"/>	33	30	165	MT4
DT-340×MT4	<input type="checkbox"/>	34	30	165	MT4
DT-350×MT4	<input type="checkbox"/>	35	30	165	MT4
DT-360×MT4	<input type="checkbox"/>	36	30	165	MT4
DT-380×MT4	<input type="checkbox"/>	38	30	165	MT4
DT-400×MT4	<input type="checkbox"/>	40	30	165	MT4
DT-420×MT4	<input type="checkbox"/>	42	35	170	MT4
DT-450×MT4	<input type="checkbox"/>	45	35	170	MT4
DT-460×MT4	<input type="checkbox"/>	46	35	170	MT4
DT-480×MT4	<input type="checkbox"/>	48	35	170	MT4
DT-500×MT4	<input type="checkbox"/>	50	35	170	MT4
DT-550×MT4	<input type="checkbox"/>	55	40	170	MT4
DT-600×MT4	<input type="checkbox"/>	60	60	170	MT4

# スロットングエンドミル DT-BS形

●2枚刃、直刃、BSテーパシャンク

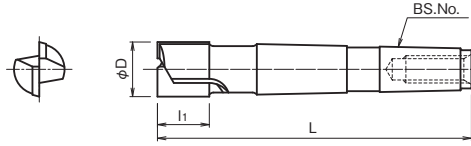

材種：K種

形番	在庫	寸法 (mm)			
		φD	l <sub>1</sub>	L	BS.No.
DT-050×BS5	<input type="checkbox"/>	5	8	63	BS5
DT-060×BS5	<input type="checkbox"/>	6	8	65	BS5
DT-070×BS5	<input type="checkbox"/>	7	10	68	BS5
DT-080×BS5	<input type="checkbox"/>	8	10	68	BS5
DT-090×BS5	<input type="checkbox"/>	9	13	70	BS5
DT-100×BS5	<input type="checkbox"/>	10	13	70	BS5
DT-110×BS5	<input type="checkbox"/>	11	16	75	BS5
DT-120×BS5	<input type="checkbox"/>	12	16	75	BS5
DT-130×BS5	<input type="checkbox"/>	13	16	75	BS5
DT-140×BS5	<input type="checkbox"/>	14	16	75	BS5
DT-140×BS7	<input type="checkbox"/>	14	16	107	BS7
DT-150×BS5	<input type="checkbox"/>	15	19	78	BS5
DT-150×BS7	<input type="checkbox"/>	15	19	110	BS7
DT-160×BS7	<input type="checkbox"/>	16	19	110	BS7
DT-170×BS7	<input type="checkbox"/>	17	19	110	BS7
DT-180×BS7	<input type="checkbox"/>	18	19	110	BS7
DT-190×BS7	<input type="checkbox"/>	19	19	115	BS7
DT-200×BS7	<input type="checkbox"/>	20	19	115	BS7
DT-210×BS7	<input type="checkbox"/>	21	19	115	BS7
DT-220×BS7	<input type="checkbox"/>	22	19	115	BS7
DT-230×BS7	<input type="checkbox"/>	23	25	124	BS7
DT-230×BS9	<input type="checkbox"/>	23	25	150	BS9
DT-240×BS7	<input type="checkbox"/>	24	25	124	BS7
DT-240×BS9	<input type="checkbox"/>	24	25	150	BS9
DT-250×BS7	<input type="checkbox"/>	25	25	124	BS7
DT-250×BS9	<input type="checkbox"/>	25	25	150	BS9
DT-260×BS7	<input type="checkbox"/>	26	25	124	BS7
DT-260×BS9	<input type="checkbox"/>	26	25	150	BS9
DT-270×BS7	<input type="checkbox"/>	27	25	124	BS7
DT-270×BS9	<input type="checkbox"/>	27	25	150	BS9
DT-280×BS7	<input type="checkbox"/>	28	25	124	BS7
DT-280×BS9	<input type="checkbox"/>	28	25	150	BS9
DT-290×BS9	<input type="checkbox"/>	29	25	155	BS9
DT-300×BS9	<input type="checkbox"/>	30	25	155	BS9
DT-310×BS9	<input type="checkbox"/>	31	25	155	BS9
DT-320×BS9	<input type="checkbox"/>	32	25	155	BS9
DT-330×BS9	<input type="checkbox"/>	33	30	160	BS9
DT-340×BS9	<input type="checkbox"/>	34	30	160	BS9
DT-350×BS9	<input type="checkbox"/>	35	30	160	BS9
DT-360×BS9	<input type="checkbox"/>	36	30	160	BS9
DT-370×BS9	<input type="checkbox"/>	37	30	160	BS9
DT-380×BS9	<input type="checkbox"/>	38	30	160	BS9
DT-390×BS9	<input type="checkbox"/>	39	30	160	BS9
DT-400×BS9	<input type="checkbox"/>	40	30	160	BS9
DT-410×BS9	<input type="checkbox"/>	41	35	165	BS9
DT-420×BS9	<input type="checkbox"/>	42	35	165	BS9
DT-430×BS9	<input type="checkbox"/>	43	35	165	BS9
DT-440×BS9	<input type="checkbox"/>	44	35	165	BS9
DT-450×BS9	<input type="checkbox"/>	45	35	165	BS9
DT-460×BS9	<input type="checkbox"/>	46	35	165	BS9
DT-470×BS9	<input type="checkbox"/>	47	35	165	BS9
DT-480×BS9	<input type="checkbox"/>	48	35	165	BS9
DT-490×BS9	<input type="checkbox"/>	49	35	165	BS9
DT-500×BS9	<input type="checkbox"/>	50	35	165	BS9
DT-550×BS9	<input type="checkbox"/>	55	40	165	BS9
DT-600×BS9	<input type="checkbox"/>	60	60	190	BS9

# スロットングエンドミル DT-BS形

●2枚刃、直刃、BSテーパシャンク

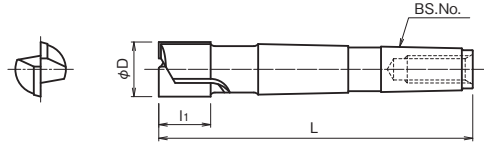

材種：M種

形番	在庫	寸法 (mm)			
		φD	l <sub>1</sub>	L	BS.No.
DT-050×BS5	<input type="checkbox"/>	5	8	63	BS5
DT-060×BS5	<input type="checkbox"/>	6	8	65	BS5
DT-070×BS5	<input type="checkbox"/>	7	10	68	BS5
DT-080×BS5	<input type="checkbox"/>	8	10	68	BS5
DT-090×BS5	<input type="checkbox"/>	9	13	70	BS5
DT-100×BS5	<input type="checkbox"/>	10	13	70	BS5
DT-110×BS5	<input type="checkbox"/>	11	16	75	BS5
DT-120×BS5	<input type="checkbox"/>	12	16	75	BS5
DT-130×BS5	<input type="checkbox"/>	13	16	75	BS5
DT-140×BS5	<input type="checkbox"/>	14	16	75	BS5
DT-140×BS7	<input type="checkbox"/>	14	16	107	BS7
DT-150×BS5	<input type="checkbox"/>	15	19	78	BS5
DT-150×BS7	<input type="checkbox"/>	15	19	110	BS7
DT-160×BS7	<input type="checkbox"/>	16	19	110	BS7
DT-170×BS7	<input type="checkbox"/>	17	19	110	BS7
DT-180×BS7	<input type="checkbox"/>	18	19	110	BS7
DT-190×BS7	<input type="checkbox"/>	19	19	115	BS7
DT-200×BS7	<input type="checkbox"/>	20	19	115	BS7
DT-210×BS7	<input type="checkbox"/>	21	19	115	BS7
DT-220×BS7	<input type="checkbox"/>	22	19	115	BS7
DT-230×BS7	<input type="checkbox"/>	23	25	124	BS7
DT-240×BS7	<input type="checkbox"/>	24	25	124	BS7
DT-250×BS7	<input type="checkbox"/>	25	25	124	BS7
DT-250×BS9	<input type="checkbox"/>	25	25	150	BS9
DT-260×BS7	<input type="checkbox"/>	26	25	124	BS7
DT-260×BS9	<input type="checkbox"/>	26	25	150	BS9
DT-270×BS9	<input type="checkbox"/>	27	25	150	BS9
DT-280×BS9	<input type="checkbox"/>	28	25	150	BS9
DT-290×BS9	<input type="checkbox"/>	29	25	155	BS9
DT-300×BS9	<input type="checkbox"/>	30	25	155	BS9
DT-310×BS9	<input type="checkbox"/>	31	25	155	BS9
DT-320×BS9	<input type="checkbox"/>	32	25	155	BS9
DT-330×BS9	<input type="checkbox"/>	33	30	160	BS9
DT-340×BS9	<input type="checkbox"/>	34	30	160	BS9
DT-350×BS9	<input type="checkbox"/>	35	30	160	BS9
DT-360×BS9	<input type="checkbox"/>	36	30	160	BS9
DT-370×BS9	<input type="checkbox"/>	37	30	160	BS9
DT-380×BS9	<input type="checkbox"/>	38	30	160	BS9
DT-390×BS9	<input type="checkbox"/>	39	30	160	BS9
DT-400×BS9	<input type="checkbox"/>	40	30	160	BS9
DT-410×BS9	<input type="checkbox"/>	41	35	165	BS9
DT-420×BS9	<input type="checkbox"/>	42	35	165	BS9
DT-430×BS9	<input type="checkbox"/>	43	35	165	BS9
DT-440×BS9	<input type="checkbox"/>	44	35	165	BS9
DT-450×BS9	<input type="checkbox"/>	45	35	165	BS9
DT-460×BS9	<input type="checkbox"/>	46	35	165	BS9
DT-470×BS9	<input type="checkbox"/>	47	35	165	BS9
DT-480×BS9	<input type="checkbox"/>	48	35	165	BS9
DT-490×BS9	<input type="checkbox"/>	49	35	165	BS9
DT-500×BS9	<input type="checkbox"/>	50	35	165	BS9
DT-550×BS9	<input type="checkbox"/>	55	40	165	BS9
DT-600×BS9	<input type="checkbox"/>	60	60	190	BS9

## CBNボールエンドミル

## JBN-BE形

●1枚刃、直刃

材種：CBN

形番	在庫	寸法 (mm)					
		R	φD	l <sub>1</sub>	l <sub>2</sub>	L	φd
JBN-BE020	<input type="checkbox"/>	1	2	1.8	5	55	6
JBN-BE030	<input type="checkbox"/>	1.5	3	2	10	65	6
JBN-BE040	<input type="checkbox"/>	2	5	3	10	65	6
JBN-BE050	<input type="checkbox"/>	2.5	5	4	15	75	6
JBN-BE060	<input type="checkbox"/>	3	6	4.5	15	75	6
JBN-BE070	<input type="checkbox"/>	3.5	7	5	19	90	8
JBN-BE080	<input type="checkbox"/>	4	8	5.5	19	90	8
JBN-BE090	<input type="checkbox"/>	4.5	9	5.5	23	100	10
JBN-BE100	<input type="checkbox"/>	5	10	6	23	100	10
JBN-BE120	<input type="checkbox"/>	6	12	7	26	130	12

71

R部スクイ角付き  
ソリッドボールエンドミル  
(ステンレス用) **DZ-DBPS**形

- ステンレス用、DZコート(TiAlN系)
- 2枚刃、エキセントリックリリーフ形、ねじれ角25°

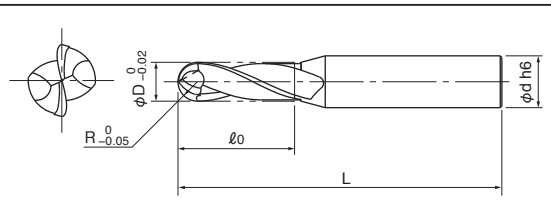

形番	在庫	寸法(mm)				
		R	ϕD	ℓ₀	L	ϕd
DZ-DBPS2010	<input type="checkbox"/>	0.5	1	1.5	50	4
DZ-DBPS2020	<input type="checkbox"/>	1	2	3	50	6
DZ-DBPS2030	<input type="checkbox"/>	1.5	3	4.5	60	6
DZ-DBPS2040	<input type="checkbox"/>	2	4	6	70	6
DZ-DBPS2050	<input type="checkbox"/>	2.5	5	7.5	80	6
DZ-DBPS2060	<input type="checkbox"/>	3	6	9	90	6
DZ-DBPS2080	<input type="checkbox"/>	4	8	12	100	8
DZ-DBPS2100	<input type="checkbox"/>	5	10	15	100	10
DZ-DBPS2120	<input type="checkbox"/>	6	12	18	110	12

71

**DZ-COAT**  
ソリッドボールエンドミル **DZ-DBSS-S**形

- 2枚刃ストレートネック形、ねじれ角25°
- ショートタイプ

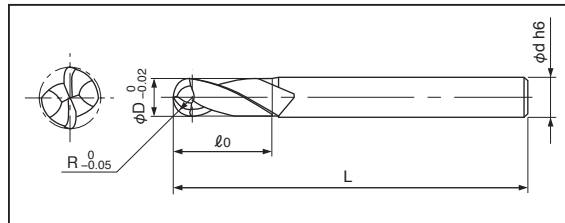

形番	在庫	寸法(mm)				
		R	ϕD	ℓ₀	L	ϕd
DZ-DBSS2040S060	<input type="checkbox"/>	2	4	10	60	4
DZ-DBSS2060S070	<input type="checkbox"/>	3	6	15	70	6
DZ-DBSS2080S075	<input type="checkbox"/>	4	8	19	75	8
DZ-DBSS2100S080	<input type="checkbox"/>	5	10	23	80	10
DZ-DBSS2120S085	<input type="checkbox"/>	6	12	26	85	12
DZ-DBSS2160S100	<input type="checkbox"/>	8	16	26	100	16
DZ-DBSS2200S100	<input type="checkbox"/>	10	20	26	100	20
DZ-DBSS2250S100	<input type="checkbox"/>	12.5	25	30	100	25

71



DZ-COAT  
ソリッドボールエンドミル **DZ-DBSM-S形**

- 2枚刃ストレートネック形、ねじれ角25°
- ミドルタイプ

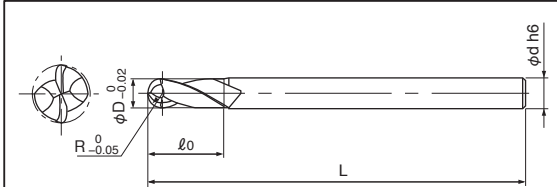

形番	在庫	寸法(mm)				
		R	φD	ℓ0	L	φd
DZ-DBSM2040S080	<input type="checkbox"/>	2	4	10	80	4
DZ-DBSM2060S090	<input type="checkbox"/>	3	6	15	90	6
DZ-DBSM2060S120	<input type="checkbox"/>	3	6	15	120	6
DZ-DBSM2080S090	<input type="checkbox"/>	4	8	19	90	8
DZ-DBSM2080S120	<input type="checkbox"/>	4	8	19	120	8
DZ-DBSM2100S100	<input type="checkbox"/>	5	10	23	100	10
DZ-DBSM2100S140	<input type="checkbox"/>	5	10	23	140	10
DZ-DBSM2120S100	<input type="checkbox"/>	6	12	26	100	12
DZ-DBSM2120S140	<input type="checkbox"/>	6	12	26	140	12
DZ-DBSM2160S140	<input type="checkbox"/>	8	16	30	140	16
DZ-DBSM2160S180	<input type="checkbox"/>	8	16	40	180	16
DZ-DBSM2200S140	<input type="checkbox"/>	10	20	30	140	20
DZ-DBSM2200S180	<input type="checkbox"/>	10	20	40	180	20
DZ-DBSM2250S140	<input type="checkbox"/>	12.5	25	40	140	25
DZ-DBSM2250S180	<input type="checkbox"/>	12.5	25	50	180	25
	<input type="checkbox"/>					
	<input type="checkbox"/>					
	<input type="checkbox"/>					
	<input type="checkbox"/>					
	<input type="checkbox"/>					
	<input type="checkbox"/>					
	<input type="checkbox"/>					
	<input type="checkbox"/>					
	<input type="checkbox"/>					
	<input type="checkbox"/>					
	<input type="checkbox"/>					
	<input type="checkbox"/>					
	<input type="checkbox"/>					
	<input type="checkbox"/>					
	<input type="checkbox"/>					
	<input type="checkbox"/>					
	<input type="checkbox"/>					
	<input type="checkbox"/>					
	<input type="checkbox"/>					
	<input type="checkbox"/>					
	<input type="checkbox"/>					
	<input type="checkbox"/>					
	<input type="checkbox"/>					
	<input type="checkbox"/>					
	<input type="checkbox"/>					
	<input type="checkbox"/>					
	<input type="checkbox"/>					
	<input type="checkbox"/>					

61

DZ-COAT  
ソリッドボールエンドミル **DZ-TSBS形**

- 2枚刃超ミニチュアタイプ

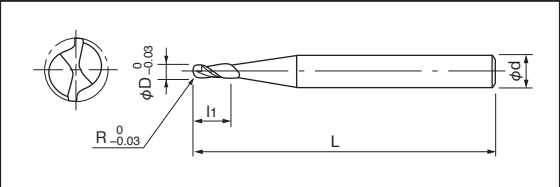

材質：DZコート (TiAlN系)

形番	在庫	寸法(mm)				
		R	φD	ℓ1	L	φd
DZ-TSBS-R0.1	<input type="checkbox"/>	0.1	0.2	0.4	40	3
DZ-TSBS-R0.15	<input type="checkbox"/>	0.15	0.3	0.6	40	3
DZ-TSBS-R0.2	<input type="checkbox"/>	0.2	0.4	1	40	3
DZ-TSBS-R0.3	<input type="checkbox"/>	0.3	0.6	2	40	3
DZ-TSBS-R0.4	<input type="checkbox"/>	0.4	0.8	2.5	40	3
DZ-TSBS-R0.5	<input type="checkbox"/>	0.5	1	3	40	4
DZ-TSBS-R0.6	<input type="checkbox"/>	0.6	1.2	5	40	4
DZ-TSBS-R0.7	<input type="checkbox"/>	0.7	1.4	5	40	4
DZ-TSBS-R0.8	<input type="checkbox"/>	0.8	1.6	5	40	4
DZ-TSBS-R0.9	<input type="checkbox"/>	0.9	1.8	5	40	4
DZ-TSBS-R1	<input type="checkbox"/>	1	2	6	40	4
DZ-TSBS-R1.1	<input type="checkbox"/>	1.1	2.2	6	40	4
DZ-TSBS-R1.2	<input type="checkbox"/>	1.2	2.4	8	40	4
DZ-TSBS-R1.3	<input type="checkbox"/>	1.3	2.6	8	40	4
DZ-TSBS-R1.4	<input type="checkbox"/>	1.4	2.8	8	40	4
DZ-TSBS-R1.5	<input type="checkbox"/>	1.5	3	8	45	4
DZ-TSBS-R1.6	<input type="checkbox"/>	1.6	3.2	8	45	4
DZ-TSBS-R1.7	<input type="checkbox"/>	1.7	3.4	10	45	4
DZ-TSBS-R1.8	<input type="checkbox"/>	1.8	3.6	10	45	4
DZ-TSBS-R1.9	<input type="checkbox"/>	1.9	3.8	10	45	4
DZ-TSBS-R2	<input type="checkbox"/>	2	4	12	45	6
DZ-TSBS-R2.1	<input type="checkbox"/>	2.1	4.2	12	45	6
DZ-TSBS-R2.2	<input type="checkbox"/>	2.2	4.4	12	45	6
DZ-TSBS-R2.3	<input type="checkbox"/>	2.3	4.6	12	45	6
DZ-TSBS-R2.4	<input type="checkbox"/>	2.4	4.8	12	45	6
DZ-TSBS-R2.5	<input type="checkbox"/>	2.5	5	12	45	6
DZ-TSBS-R2.6	<input type="checkbox"/>	2.6	5.2	15	60	6
DZ-TSBS-R2.7	<input type="checkbox"/>	2.7	5.4	15	60	6
DZ-TSBS-R2.8	<input type="checkbox"/>	2.8	5.6	15	60	6
DZ-TSBS-R2.9	<input type="checkbox"/>	2.9	5.8	15	60	6
DZ-TSBS-R3	<input type="checkbox"/>	3	6	15	60	6

94

## DX-COAT ソリッドボールエンドミル SBEL-D形

●2枚刃、ロング刃長

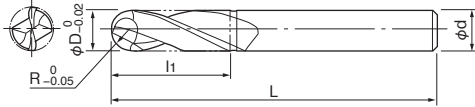

材種：DXコート(TiCN系)

形番	在庫	寸法 (mm)				
		R	φD	l1	L	φd
SBEL-R0.5D	<input type="checkbox"/>	0.5	1	5	45	4
SBEL-R0.75D	<input type="checkbox"/>	0.75	1.5	8	45	4
SBEL-R1.0D	<input type="checkbox"/>	1	2	10	50	4
SBEL-R1.25D	<input type="checkbox"/>	1.25	2.5	13	50	4
SBEL-R1.5D	<input type="checkbox"/>	1.5	3	15	55	4
SBEL-R1.75D	<input type="checkbox"/>	1.75	3.5	18	55	4
SBEL-R2.0D	<input type="checkbox"/>	2	4	20	60	4
SBEL-R2.25D	<input type="checkbox"/>	2.25	4.5	23	60	6
SBEL-R2.5D	<input type="checkbox"/>	2.5	5	25	70	6
SBEL-R2.75D	<input type="checkbox"/>	2.75	5.5	28	80	6
SBEL-R3.0D	<input type="checkbox"/>	3	6	30	80	6
SBEL-R3.5D	<input type="checkbox"/>	3.5	7	30	80	8
SBEL-R4.0D	<input type="checkbox"/>	4	8	35	90	8
SBEL-R4.5D	<input type="checkbox"/>	4.5	9	40	90	10
SBEL-R5.0D	<input type="checkbox"/>	5	10	45	100	10
SBEL-R5.5D	<input type="checkbox"/>	5.5	11	45	100	12
SBEL-R6.0D	<input type="checkbox"/>	6	12	50	100	12
SBEL-R6.5D	<input type="checkbox"/>	6.5	13	50	110	12
SBEL-R7.0D	<input type="checkbox"/>	7	14	55	120	16
SBEL-R7.5D	<input type="checkbox"/>	7.5	15	55	120	16
SBEL-R8.0D	<input type="checkbox"/>	8	16	55	130	16
SBEL-R8.5D	<input type="checkbox"/>	8.5	17	55	130	20
SBEL-R9.0D	<input type="checkbox"/>	9	18	55	130	20
SBEL-R9.5D	<input type="checkbox"/>	9.5	19	58	140	20
SBEL-R10.0D	<input type="checkbox"/>	10	20	60	150	20
SBEL-R12.5D	<input type="checkbox"/>	12.5	25	65	150	25

61

## DX-COAT ソリッドボールエンドミル DBS1-D形

●2枚刃

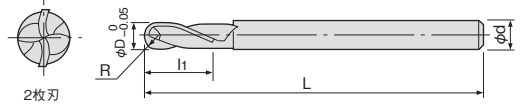

材種：DXコート(TiCN系)

形番	在庫	寸法 (mm)				
		R	φD	l1	L	φd
DBS1-030-D	<input type="checkbox"/>	1.5	3	10	60	6
DBS1-040-D	<input type="checkbox"/>	2.0	4	10	60	6
DBS1-050-D	<input type="checkbox"/>	2.5	5	15	70	6
DBS1-060-D	<input type="checkbox"/>	3.0	6	15	70	6
DBS1-070-D	<input type="checkbox"/>	3.5	7	19	75	8
DBS1-080-D	<input type="checkbox"/>	4.0	8	19	75	8
DBS1-090-D	<input type="checkbox"/>	4.5	9	23	80	10
DBS1-100-D	<input type="checkbox"/>	5.0	10	23	80	10
DBS1-110-D	<input type="checkbox"/>	5.5	11	26	85	12
DBS1-120-D	<input type="checkbox"/>	6.0	12	26	85	12

815



# グラフアイト用 ソリッドボールエンドミル **GF-SBX形**

- 2枚刃、ねじれ角30°
- 超ロングタイプ

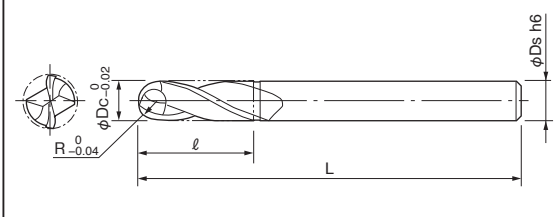

形番	在庫	寸法 (mm)				
		R	φDc	ℓ	L	φDs
GF-SBX 2020	<input type="checkbox"/>	1	2	20	100	6
GF-SBX 2030	<input type="checkbox"/>	1.5	3	30	100	6
GF-SBX 2040	<input type="checkbox"/>	2	4	60	110	6
GF-SBX 2050	<input type="checkbox"/>	2.5	5	70	125	6
GF-SBX 2060	<input type="checkbox"/>	3	6	80	130	6
GF-SBX 2080	<input type="checkbox"/>	4	8	100	150	8
GF-SBX 2100	<input type="checkbox"/>	5	10	120	170	10
GF-SBX 2120	<input type="checkbox"/>	6	12	130	190	12

6415



## ソリッド ボールエンドミル

### DYK-2形

●2枚刃、ねじれ刃



## ソリッド ボールエンドミル

### DYK-1形

●2枚刃、直刃

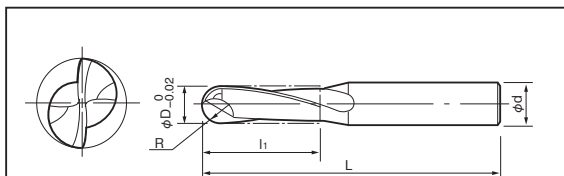

材種：超微粒子超硬合金

形番 Cat. No.	在庫 Stock	寸法 (mm) Dimensions (mm)				
		R	φD	L1	L	φd
DYK-201	<input type="checkbox"/>	1.5	3	22	75	6
DYK-202	<input type="checkbox"/>	2	4	22	75	6
DYK-203	<input type="checkbox"/>	2.5	5	22	75	6
DYK-204	<input type="checkbox"/>	3	6	28	85	6
DYK-205	<input type="checkbox"/>	3.5	7	28	85	8
DYK-206	<input type="checkbox"/>	4	8	28	95	8
DYK-207	<input type="checkbox"/>	4.5	9	28	95	10
DYK-208	<input type="checkbox"/>	5	10	28	95	10
DYK-209	<input type="checkbox"/>	5.5	11	35	110	12
DYK-210	<input type="checkbox"/>	6	12	35	110	12
DYK-211	<input type="checkbox"/>	6.5	13	35	110	12
DYK-212	<input type="checkbox"/>	7	14	35	120	16
DYK-213	<input type="checkbox"/>	7.5	15	40	120	16
DYK-214	<input type="checkbox"/>	8	16	40	130	18
DYK-215	<input type="checkbox"/>	8.5	17	40	130	18
DYK-216	<input type="checkbox"/>	9	18	40	130	18
DYK-217	<input type="checkbox"/>	9.5	19	40	140	20
DYK-218	<input type="checkbox"/>	10	20	40	140	20

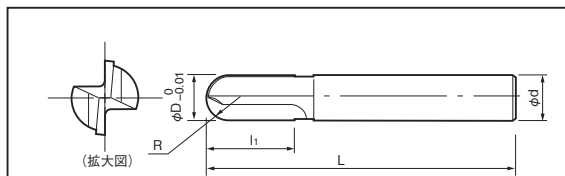

材種：超微粒子超硬合金

形番 Cat. No.	在庫 Stock	寸法 (mm) Dimensions (mm)				
		R	φD	L1	L	φd
DYK-101	<input type="checkbox"/>	1	2	20	75	6
DYK-102	<input type="checkbox"/>	1.5	3	20	75	6
DYK-103	<input type="checkbox"/>	2	4	20	75	6
DYK-104	<input type="checkbox"/>	2.5	5	25	75	6
DYK-105	<input type="checkbox"/>	3	6	25	80	6
DYK-106	<input type="checkbox"/>	3.5	7	25	80	6
DYK-107	<input type="checkbox"/>	4	8	25	80	8
DYK-108	<input type="checkbox"/>	4.5	9	25	80	8
DYK-109	<input type="checkbox"/>	5	10	25	90	10
DYK-110	<input type="checkbox"/>	5.5	11	30	110	12
DYK-111	<input type="checkbox"/>	6	12	30	110	12
DYK-112	<input type="checkbox"/>	6.5	13	30	110	12
DYK-113	<input type="checkbox"/>	7	14	30	110	12
DYK-114	<input type="checkbox"/>	7.5	15	30	110	12
DYK-115	<input type="checkbox"/>	8	16	35	120	16
DYK-116	<input type="checkbox"/>	8.5	17	35	120	16
DYK-117	<input type="checkbox"/>	9	18	35	120	16
DYK-118	<input type="checkbox"/>	9.5	19	35	120	20
DYK-119	<input type="checkbox"/>	10	20	35	120	20

# ソリッド ボールエンドミル SCBE形

●2枚刃、ミニチュアタイプ



# ソリッド ボールエンドミル LN-SBEL形

●2枚刃、ミディアムロング

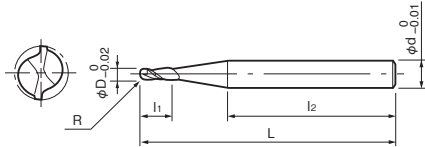

材種：超微粒子超硬合金

形番 Cat. No.	在庫 Stock	寸法 (mm) Dimensions (mm)					
		R	φD	l <sub>1</sub>	l <sub>2</sub>	L	φd
SCBE-2003	<input type="checkbox"/>	0.15	0.3	1	30.8	40	3
SCBE-2004	<input type="checkbox"/>	0.2	0.4	1	31.1	40	3
SCBE-2005	<input type="checkbox"/>	0.25	0.5	1	31.4	40	3
SCBE-2006	<input type="checkbox"/>	0.3	0.6	2	30.7	40	3
SCBE-2007	<input type="checkbox"/>	0.35	0.7	2	31	40	3
SCBE-2008	<input type="checkbox"/>	0.4	0.8	2.5	30.8	40	3
SCBE-2009	<input type="checkbox"/>	0.45	0.9	2.5	31.1	40	3
SCBE-2010	<input type="checkbox"/>	0.5	1	3	28	40	4
SCBE-2011	<input type="checkbox"/>	0.55	1.1	3	28.3	40	4
SCBE-2012	<input type="checkbox"/>	0.6	1.2	3	28.6	40	4
SCBE-2014	<input type="checkbox"/>	0.7	1.4	3	29.1	40	4
SCBE-2015	<input type="checkbox"/>	0.75	1.5	5	27.4	40	4
SCBE-2016	<input type="checkbox"/>	0.8	1.6	5	27.7	40	4
SCBE-2018	<input type="checkbox"/>	0.9	1.8	5	28.3	40	4
SCBE-2020	<input type="checkbox"/>	1	2	6	27.8	40	4
SCBE-2022	<input type="checkbox"/>	1.1	2.2	6	28.4	40	4
SCBE-2024	<input type="checkbox"/>	1.2	2.4	6	29	40	4
SCBE-2025	<input type="checkbox"/>	1.25	2.5	8	27.2	40	4
SCBE-2026	<input type="checkbox"/>	1.3	2.6	8	27.5	40	4
SCBE-2028	<input type="checkbox"/>	1.4	2.8	8	28.1	40	4
SCBE-2030	<input type="checkbox"/>	1.5	3	8	33.2	45	4
SCBE-2032	<input type="checkbox"/>	1.6	3.2	10	31.7	45	4
SCBE-2034	<input type="checkbox"/>	1.7	3.4	10	32.3	45	4
SCBE-2035	<input type="checkbox"/>	1.75	3.5	10	32.6	45	4
SCBE-2036	<input type="checkbox"/>	1.8	3.6	10	32.9	45	4
SCBE-2038	<input type="checkbox"/>	1.9	3.8	10	33.4	45	4
SCBE-2040	<input type="checkbox"/>	2	4	12	26.3	45	4

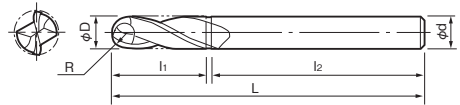

材種：超微粒子超硬合金

形番 Cat. No.	在庫 Stock	寸法 (mm) Dimensions (mm)					
		R	φD	l <sub>1</sub>	l <sub>2</sub>	L	φd
LN-SBEL-R1	<input type="checkbox"/>	1	2	10	66	100	4
LN-SBEL-R1.25	<input type="checkbox"/>	1.25	2.5	13	67	100	4
LN-SBEL-R1.5	<input type="checkbox"/>	1.5	3	15	68	100	4
LN-SBEL-R1.75	<input type="checkbox"/>	1.75	3.5	18	69	100	4
LN-SBEL-R2	<input type="checkbox"/>	2	4	20	77	100	4
LN-SBEL-R2.25	<input type="checkbox"/>	2.25	4.5	23	67	120	6
LN-SBEL-R2.5	<input type="checkbox"/>	2.5	5	25	68	120	6
LN-SBEL-R2.75	<input type="checkbox"/>	2.75	5.5	28	69	120	6
LN-SBEL-R3	<input type="checkbox"/>	3	6	30	87	120	6
LN-SBEL-R3.5	<input type="checkbox"/>	3.5	7	30	78	140	8
LN-SBEL-R4	<input type="checkbox"/>	4	8	35	102	140	8
LN-SBEL-R4.5	<input type="checkbox"/>	4.5	9	40	88	170	10
LN-SBEL-R5	<input type="checkbox"/>	5	10	45	122	170	10
LN-SBEL-R5.5	<input type="checkbox"/>	5.5	11	45	130	180	10
LN-SBEL-R6	<input type="checkbox"/>	6	12	50	127	180	12
LN-SBEL-R6.5	<input type="checkbox"/>	6.5	13	50	125	180	12
LN-SBEL-R7	<input type="checkbox"/>	7	14	55	86	190	16
LN-SBEL-R7.5	<input type="checkbox"/>	7.5	15	55	88	190	16
LN-SBEL-R8	<input type="checkbox"/>	8	16	55	132	190	16
LN-SBEL-R8.5	<input type="checkbox"/>	8.5	17	55	140	200	16
LN-SBEL-R9	<input type="checkbox"/>	9	18	55	86	200	20
LN-SBEL-R9.5	<input type="checkbox"/>	9.5	19	58	88	200	20
LN-SBEL-R10	<input type="checkbox"/>	10	20	60	137	200	20
LN-SBEL-R12.5	<input type="checkbox"/>	12.5	25	65	132	200	25
LN-SBEL-R15	<input type="checkbox"/>	15	30	80	86	200	32



# ソリッド ボールエンドミル

## LS-SBE形

●2枚刃、ロングシャンク

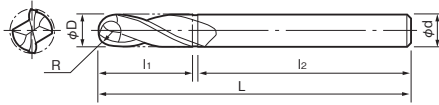

材種：超微粒子超硬合金

形番 Cat. No.	在庫 Stock	寸法 (mm) Dimensions (mm)					
		R	φD	l <sub>1</sub>	l <sub>2</sub>	L	φd
LS-SBE-R1	<input type="checkbox"/>	1	2	4	118	140	4
LS-SBE-R1.25	<input type="checkbox"/>	1.25	2.5	4	117	140	4
LS-SBE-R1.5	<input type="checkbox"/>	1.5	3	6	119	140	4
LS-SBE-R1.75	<input type="checkbox"/>	1.75	3.5	8	118	140	6
LS-SBE-R2	<input type="checkbox"/>	2	4	8	113	140	6
LS-SBE-R2.25	<input type="checkbox"/>	2.25	4.5	12	124	150	6
LS-SBE-R2.5	<input type="checkbox"/>	2.5	5	12	124	150	6
LS-SBE-R2.75	<input type="checkbox"/>	2.75	5.5	20	125	150	6
LS-SBE-R3	<input type="checkbox"/>	3	6	20	125	150	6
LS-SBE-R3.25	<input type="checkbox"/>	3.25	6.5	20	125	150	6
LS-SBE-R3.5	<input type="checkbox"/>	3.5	7	25	150	180	8
LS-SBE-R3.75	<input type="checkbox"/>	3.75	7.5	25	150	180	8
LS-SBE-R4	<input type="checkbox"/>	4	8	25	150	180	8
LS-SBE-R4.25	<input type="checkbox"/>	4.25	8.5	25	150	180	8
LS-SBE-R4.5	<input type="checkbox"/>	4.5	9	30	160	200	10
LS-SBE-R4.75	<input type="checkbox"/>	4.75	9.5	30	160	200	10
LS-SBE-R5	<input type="checkbox"/>	5	10	40	180	230	10
LS-SBE-R5.5	<input type="checkbox"/>	5.5	11	40	180	230	10
LS-SBE-R6	<input type="checkbox"/>	6	12	45	175	230	12
LS-SBE-R6.5	<input type="checkbox"/>	6.5	13	45	175	230	12
LS-SBE-R7	<input type="checkbox"/>	7	14	50	190	250	16
LS-SBE-R7.5	<input type="checkbox"/>	7.5	15	50	190	250	16
LS-SBE-R8	<input type="checkbox"/>	8	16	50	190	250	16
LS-SBE-R8.5	<input type="checkbox"/>	8.5	17	50	190	250	16
LS-SBE-R9	<input type="checkbox"/>	9	18	50	190	250	20
LS-SBE-R9.5	<input type="checkbox"/>	9.5	19	50	190	250	20
LS-SBE-R10	<input type="checkbox"/>	10	20	50	190	250	20
LS-SBE-R12.5	<input type="checkbox"/>	12.5	25	50	190	250	25
LS-SBE-R15	<input type="checkbox"/>	15	30	70	170	250	32

741

# ソリッド ボールエンドミル

## SBEL形

●2枚刃、ロング刃長

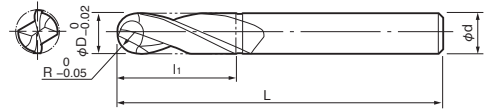

材種：超微粒子超硬合金

形番 Cat. No.	在庫 Stock	寸法 (mm) Dimensions (mm)				
		R	φD	l <sub>1</sub>	L	φd
SBEL-R0.5	<input type="checkbox"/>	0.5	1	5	45	4
SBEL-R0.6	<input type="checkbox"/>	0.6	1.2	5	45	4
SBEL-R0.7	<input type="checkbox"/>	0.7	1.4	8	45	4
SBEL-R0.75	<input type="checkbox"/>	0.75	1.5	8	45	4
SBEL-R0.8	<input type="checkbox"/>	0.8	1.6	8	45	4
SBEL-R0.9	<input type="checkbox"/>	0.9	1.8	8	45	4
SBEL-R1.0	<input type="checkbox"/>	1.0	2	10	50	4
SBEL-R1.25	<input type="checkbox"/>	1.25	2.5	13	50	4
SBEL-R1.5	<input type="checkbox"/>	1.5	3	15	55	4
SBEL-R1.75	<input type="checkbox"/>	1.75	3.5	18	55	4
SBEL-R2.0	<input type="checkbox"/>	2.0	4	20	60	4
SBEL-R2.25	<input type="checkbox"/>	2.25	4.5	23	60	6
SBEL-R2.5	<input type="checkbox"/>	2.5	5	25	70	6
SBEL-R2.75	<input type="checkbox"/>	2.75	5.5	28	80	6
SBEL-R3.0	<input type="checkbox"/>	3.0	6	30	80	6
SBEL-R3.25	<input type="checkbox"/>	3.25	6.5	30	80	6
SBEL-R3.5	<input type="checkbox"/>	3.5	7	30	80	8
SBEL-R3.75	<input type="checkbox"/>	3.75	7.5	35	90	8
SBEL-R4.0	<input type="checkbox"/>	4.0	8	35	90	8
SBEL-R4.25	<input type="checkbox"/>	4.25	8.5	35	90	8
SBEL-R4.5	<input type="checkbox"/>	4.5	9	40	90	10
SBEL-R4.75	<input type="checkbox"/>	4.75	9.5	45	100	10
SBEL-R5.0	<input type="checkbox"/>	5.0	10	45	100	10
SBEL-R5.5	<input type="checkbox"/>	5.5	11	45	100	10
SBEL-R6.0	<input type="checkbox"/>	6.0	12	50	100	12
SBEL-R6.5	<input type="checkbox"/>	6.5	13	50	110	12
SBEL-R7.0	<input type="checkbox"/>	7.0	14	55	120	12
SBEL-R7.5	<input type="checkbox"/>	7.5	15	55	120	16
SBEL-R8.0	<input type="checkbox"/>	8.0	16	55	130	16
SBEL-R8.5	<input type="checkbox"/>	8.5	17	55	130	20
SBEL-R9.0	<input type="checkbox"/>	9.0	18	55	130	20
SBEL-R9.5	<input type="checkbox"/>	9.5	19	58	140	20
SBEL-R10.0	<input type="checkbox"/>	10.0	20	60	150	20
SBEL-R12.5	<input type="checkbox"/>	12.5	25	65	150	25
SBEL-R15.0	<input type="checkbox"/>	15.0	30	80	150	32

614

## ソリッド ボールエンドミル SBEL-S形

●2枚刃、首下ストレートタイプ



## ソリッド ボールエンドミル SBEL-T形

●2枚刃、首下テーパタイプ

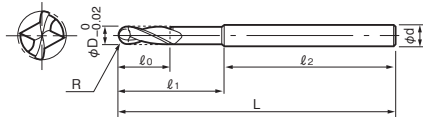

材種：超微粒子超硬合金

形番 Cat. No.	在庫 Stock	寸法 (mm) Dimensions (mm)						
		R	φD	ℓ <sub>0</sub>	ℓ <sub>1</sub>	ℓ <sub>2</sub>	L	φd
SBEL-R1.0-S	<input type="checkbox"/>	1	2	3	25	55	80	4
SBEL-R1.5-S	<input type="checkbox"/>	1.5	3	4	35	65	100	6
SBEL-R2.0-S	<input type="checkbox"/>	2	4	6	35	65	100	6
SBEL-R2.5-S	<input type="checkbox"/>	2.5	5	7	40	75	115	8
SBEL-R3.0-S	<input type="checkbox"/>	3	6	8	45	70	115	8
SBEL-R3.5-S	<input type="checkbox"/>	3.5	7	10	45	80	125	10
SBEL-R4.0-S	<input type="checkbox"/>	4	8	12	55	70	125	10
SBEL-R5.0-S	<input type="checkbox"/>	5	10	15	65	75	140	12
SBEL-R6.0-S	<input type="checkbox"/>	6	12	18	75	75	150	16
SBEL-R8.0-S	<input type="checkbox"/>	8	16	23	85	95	180	20
SBEL-R10.0-S	<input type="checkbox"/>	10	20	25	105	115	220	25

91

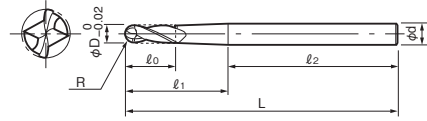

材種：超微粒子超硬合金

形番 Cat. No.	在庫 Stock	寸法 (mm) Dimensions (mm)						
		R	φD	ℓ <sub>0</sub>	ℓ <sub>1</sub>	ℓ <sub>2</sub>	L	φd
SBEL-R1.0-T	<input type="checkbox"/>	1	2	3	25	55	80	4
SBEL-R1.5-T	<input type="checkbox"/>	1.5	3	4	35	65	100	6
SBEL-R2.0-T	<input type="checkbox"/>	2	4	6	35	65	100	6
SBEL-R2.5-T	<input type="checkbox"/>	2.5	5	7	40	75	115	8
SBEL-R3.0-T	<input type="checkbox"/>	3	6	8	45	70	115	8
SBEL-R3.5-T	<input type="checkbox"/>	3.5	7	10	45	80	125	10
SBEL-R4.0-T	<input type="checkbox"/>	4	8	12	55	70	125	10
SBEL-R5.0-T	<input type="checkbox"/>	5	10	15	65	75	140	12
SBEL-R6.0-T	<input type="checkbox"/>	6	12	18	75	75	150	16
SBEL-R8.0-T	<input type="checkbox"/>	8	16	23	85	95	180	20
SBEL-R10.0-T	<input type="checkbox"/>	10	20	25	105	115	220	25

41

## ソリッド ボールエンドミル DYBS-M形

●2枚刃、ミニチュア

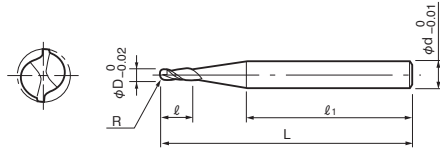

材種：超微粒子超硬合金

形番 Cat. No.	在庫 Stock	寸法 (mm) Dimensions (mm)					
		R	φD	ℓ	ℓ1	L	φd
DYBS-001M	<input type="checkbox"/>	0.05	0.1	0.3	45.5	50	3
DYBS-002M	<input type="checkbox"/>	0.1	0.2	0.5	45.5	50	3
DYBS-003M	<input type="checkbox"/>	0.15	0.3	1.2	44.6	50	3
DYBS-004M	<input type="checkbox"/>	0.2	0.4	2	43.9	50	3
DYBS-005M	<input type="checkbox"/>	0.25	0.5	2.5	43.6	50	3
DYBS-006M	<input type="checkbox"/>	0.3	0.6	2.8	43.4	50	3
DYBS-007M	<input type="checkbox"/>	0.35	0.7	3.6	42.7	50	3
DYBS-008M	<input type="checkbox"/>	0.4	0.8	4	42.3	50	3
DYBS-009M	<input type="checkbox"/>	0.45	0.9	4.5	42.1	50	3
DYBS-010M	<input type="checkbox"/>	0.5	1	5	41.8	50	3
DYBS-011M	<input type="checkbox"/>	0.55	1.1	5.6	41.3	50	3
DYBS-012M	<input type="checkbox"/>	0.6	1.2	6.2	40.9	50	3
DYBS-013M	<input type="checkbox"/>	0.65	1.3	6.2	40.9	50	3
DYBS-014M	<input type="checkbox"/>	0.7	1.4	7	40.4	50	3
DYBS-015M	<input type="checkbox"/>	0.75	1.5	7	40.4	50	3
DYBS-016M	<input type="checkbox"/>	0.8	1.6	8	39.7	50	3
DYBS-017M	<input type="checkbox"/>	0.85	1.7	8	39.7	50	3
DYBS-018M	<input type="checkbox"/>	0.9	1.8	9	39	50	3
DYBS-019M	<input type="checkbox"/>	0.95	1.9	9	39	50	3
DYBS-020M	<input type="checkbox"/>	1	2	10	38.1	50	3

21

## ソリッド ボールエンドミル ESL-SBE形

●2枚刃、超ロングシャンク

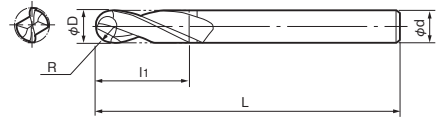

材種：超微粒子超硬合金

形番 Cat. No.	在庫 Stock	寸法 (mm) Dimensions (mm)				
		R	φD	ℓ1	L	φd
ESL-SBE-R3-250	<input type="checkbox"/>	3	6	40	250	6
ESL-SBE-R4-250	<input type="checkbox"/>	4	8	50	250	8
ESL-SBE-R5-250	<input type="checkbox"/>	5	10	60	250	10
ESL-SBE-R5-300	<input type="checkbox"/>	5	10	60	300	10
ESL-SBE-R5-330	<input type="checkbox"/>	5	10	60	330	10
ESL-SBE-R6-280	<input type="checkbox"/>	6	12	70	280	12
ESL-SBE-R6-330	<input type="checkbox"/>	6	12	70	330	12
ESL-SBE-R8-330	<input type="checkbox"/>	8	16	80	330	16
ESL-SBE-R10-300	<input type="checkbox"/>	10	20	90	300	20
ESL-SBE-R10-350	<input type="checkbox"/>	10	20	90	350	20
ESL-SBE-R12.5-300	<input type="checkbox"/>	12.5	25	100	300	25
ESL-SBE-R12.5-350	<input type="checkbox"/>	12.5	25	100	350	25

64

■R寸法許容差 (mm)

工具径φD Tool dia. φD	許容差 Tolerance
φ3, φ4	+0 -0.03
φ5以上	+0 -0.05

TSBS形

ソリッドボールエンドミル

●2枚刃

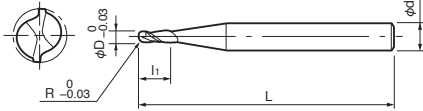

材質：超微粒子超硬合金

形番 Cat. No.	在庫 Stock	寸法 (mm) Dimensions (mm)				
		R	φD	l <sub>1</sub>	L	φd
TSBS-R0.10	□	0.10	0.2	0.4	40	3
TSBS-R0.15	□	0.15	0.3	0.6	40	3
TSBS-R0.20	□	0.20	0.4	1	40	3
TSBS-R0.25	□	0.25	0.5	1	40	3
TSBS-R0.30	□	0.30	0.6	2	40	3
TSBS-R0.35	□	0.35	0.7	2	40	3
TSBS-R0.40	□	0.40	0.8	2.5	40	3
TSBS-R0.45	□	0.45	0.9	2.5	40	3
TSBS-R0.50	□	0.50	1.0	3	40	4
TSBS-R0.55	□	0.55	1.1	3	40	4
TSBS-R0.60	□	0.60	1.2	5	40	4
TSBS-R0.65	□	0.65	1.3	5	40	4
TSBS-R0.70	□	0.70	1.4	5	40	4
TSBS-R0.75	□	0.75	1.5	5	40	4
TSBS-R0.80	□	0.80	1.6	5	40	4
TSBS-R0.85	□	0.85	1.7	5	40	4
TSBS-R0.90	□	0.90	1.8	5	40	4
TSBS-R0.95	□	0.95	1.9	5	40	4
TSBS-R1.00	□	1.00	2.0	6	40	4
TSBS-R1.05	□	1.05	2.1	6	40	4
TSBS-R1.10	□	1.10	2.2	6	40	4
TSBS-R1.15	□	1.15	2.3	6	40	4
TSBS-R1.20	□	1.20	2.4	8	40	4
TSBS-R1.25	□	1.25	2.5	8	40	4
TSBS-R1.30	□	1.30	2.6	8	40	4
TSBS-R1.35	□	1.35	2.7	8	40	4
TSBS-R1.40	□	1.40	2.8	8	40	4
TSBS-R1.45	□	1.45	2.9	8	40	4
TSBS-R1.50	□	1.50	3.0	8	45	4
TSBS-R1.55	□	1.55	3.1	8	45	4
TSBS-R1.60	□	1.60	3.2	8	45	4
TSBS-R1.65	□	1.65	3.3	8	45	4
TSBS-R1.70	□	1.70	3.4	10	45	4
TSBS-R1.75	□	1.75	3.5	10	45	4
TSBS-R1.80	□	1.80	3.6	10	45	4
TSBS-R1.85	□	1.85	3.7	10	45	4
TSBS-R1.90	□	1.90	3.8	10	45	4
TSBS-R1.95	□	1.95	3.9	10	45	4
TSBS-R2.00	□	2.00	4.0	12	45	6
TSBS-R2.05	□	2.05	4.1	12	45	6
TSBS-R2.10	□	2.10	4.2	12	45	6

形番 Cat. No.	在庫 Stock	寸法 (mm) Dimensions (mm)				
		R	φD	l <sub>1</sub>	L	φd
TSBS-R2.15	□	2.15	4.3	12	45	6
TSBS-R2.20	□	2.20	4.4	12	45	6
TSBS-R2.25	□	2.25	4.5	12	45	6
TSBS-R2.30	□	2.30	4.6	12	45	6
TSBS-R2.35	□	2.35	4.7	12	45	6
TSBS-R2.40	□	2.40	4.8	12	45	6
TSBS-R2.45	□	2.45	4.9	12	45	6
TSBS-R2.50	□	2.50	5.0	12	45	6
TSBS-R2.55	□	2.55	5.1	15	60	6
TSBS-R2.60	□	2.60	5.2	15	60	6
TSBS-R2.65	□	2.65	5.3	15	60	6
TSBS-R2.70	□	2.70	5.4	15	60	6
TSBS-R2.75	□	2.75	5.5	15	60	6
TSBS-R2.80	□	2.80	5.6	15	60	6
TSBS-R2.85	□	2.85	5.7	15	60	6
TSBS-R2.90	□	2.90	5.8	15	60	6
TSBS-R2.95	□	2.95	5.9	15	60	6
TSBS-R3.00	□	3.00	6.0	15	60	6
TSBS-R3.05	□	3.05	6.1	15	60	6
TSBS-R3.10	□	3.10	6.2	15	60	6
TSBS-R3.15	□	3.15	6.3	15	60	6
TSBS-R3.20	□	3.20	6.4	15	60	6
TSBS-R3.25	□	3.25	6.5	15	60	6
TSBS-R3.30	□	3.30	6.6	15	60	6
TSBS-R3.35	□	3.35	6.7	15	60	6
TSBS-R3.40	□	3.40	6.8	15	60	6
TSBS-R3.45	□	3.45	6.9	15	60	6
TSBS-R3.50	□	3.50	7.0	15	60	6
TSBS-R3.55	□	3.55	7.1	20	90	8
TSBS-R3.60	□	3.60	7.2	20	90	8
TSBS-R3.65	□	3.65	7.3	20	90	8
TSBS-R3.70	□	3.70	7.4	20	90	8
TSBS-R3.75	□	3.75	7.5	20	90	8
TSBS-R3.80	□	3.80	7.6	20	90	8
TSBS-R3.85	□	3.85	7.7	20	90	8
TSBS-R3.90	□	3.90	7.8	20	90	8
TSBS-R3.95	□	3.95	7.9	20	90	8
TSBS-R4.00	□	4.00	8.0	20	90	8
TSBS-R4.05	□	4.05	8.1	20	90	8
TSBS-R4.10	□	4.10	8.2	20	90	8
TSBS-R4.15	□	4.15	8.3	20	90	8
TSBS-R4.20	□	4.20	8.4	20	90	8
TSBS-R4.25	□	4.25	8.5	20	90	8
TSBS-R4.30	□	4.30	8.6	20	90	8
TSBS-R4.35	□	4.35	8.7	20	90	8
TSBS-R4.40	□	4.40	8.8	20	90	8
TSBS-R4.45	□	4.45	8.9	20	90	8
TSBS-R4.50	□	4.50	9.0	25	90	10
TSBS-R4.55	□	4.55	9.1	25	90	10
TSBS-R4.60	□	4.60	9.2	25	90	10
TSBS-R4.65	□	4.65	9.3	25	90	10
TSBS-R4.70	□	4.70	9.4	25	90	10
TSBS-R4.75	□	4.75	9.5	25	90	10
TSBS-R4.80	□	4.80	9.6	25	90	10
TSBS-R4.85	□	4.85	9.7	25	90	10
TSBS-R4.90	□	4.90	9.8	25	90	10
TSBS-R4.95	□	4.95	9.9	25	90	10
TSBS-R5.00	□	5.00	10.0	25	90	10
TSBS-R5.05	□	5.05	10.1	25	90	10
TSBS-R5.10	□	5.10	10.2	25	90	10



# ボールエンドミル

# DYK4形

●2枚テーパ刃、直刃ボールエンドミル



# 付け刃 ボールエンドミル

# BE形

●2枚刃

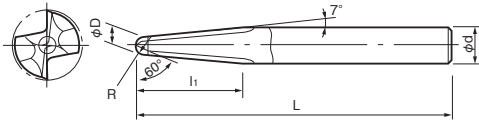

材種：超微粒子超硬合金

形番 Cat. No.	在庫 Stock	寸法 (mm) Dimensions (mm)			
		R	l <sub>1</sub>	L	φd
DYK-401	<input type="checkbox"/>	1	17.3	70	6
DYK-402	<input type="checkbox"/>	1	25.4	80	8
DYK-403	<input type="checkbox"/>	1.5	13.7	70	6
DYK-404	<input type="checkbox"/>	1.5	21.9	80	8
DYK-405	<input type="checkbox"/>	1.5	30.0	90	10
DYK-406	<input type="checkbox"/>	1.5	38.1	100	12
DYK-407	<input type="checkbox"/>	2	10.1	70	6
DYK-408	<input type="checkbox"/>	2	18.3	80	8
DYK-409	<input type="checkbox"/>	2	26.4	90	10
DYK-410	<input type="checkbox"/>	2	34.6	100	12
DYK-411	<input type="checkbox"/>	2.5	22.9	90	10
DYK-412	<input type="checkbox"/>	2.5	31.0	100	12
DYK-413	<input type="checkbox"/>	3	27.4	100	12

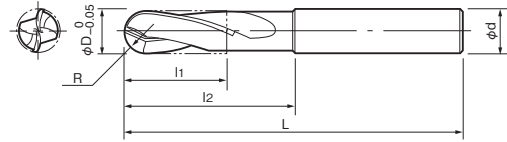

材種：K種超硬合金

形番 Cat. No.	在庫 Stock	寸法 (mm) Dimensions (mm)					
		R	φD	l <sub>1</sub>	l <sub>2</sub>	L	φd
BE-R5	<input type="checkbox"/>	5.0	10	30	48	120	10
BE-R6	<input type="checkbox"/>	6.0	12	30	48	120	12
BE-R7	<input type="checkbox"/>	7.0	14	40	48	120	12
BE-R7.5	<input type="checkbox"/>	7.5	15	40	48	120	16
BE-R8	<input type="checkbox"/>	8.0	16	50	70	160	16
BE-R8.5	<input type="checkbox"/>	8.5	17	50	70	160	16
BE-R9	<input type="checkbox"/>	9.0	18	50	70	160	16
BE-R9.5	<input type="checkbox"/>	9.5	19	50	70	160	20
BE-R10	<input type="checkbox"/>	10.0	20	60	70	160	20
BE-R10.5	<input type="checkbox"/>	10.5	21	60	70	160	20
BE-R11	<input type="checkbox"/>	11.0	22	60	70	160	20
BE-R11.5	<input type="checkbox"/>	11.5	23	60	100	200	25
BE-R12	<input type="checkbox"/>	12.0	24	60	100	200	25
BE-R12.5	<input type="checkbox"/>	12.5	25	60	100	200	25
BE-R13	<input type="checkbox"/>	13.0	26	60	100	200	25
BE-R14	<input type="checkbox"/>	14.0	28	60	100	200	25
BE-R15	<input type="checkbox"/>	15.0	30	60	100	200	25
BE-R16	<input type="checkbox"/>	16.0	32	60	112	220	32
BE-R18	<input type="checkbox"/>	18.0	36	70	112	220	32
BE-R20	<input type="checkbox"/>	20.0	40	80	112	220	32
BE-R22	<input type="checkbox"/>	22.0	44	80	120	240	42
BE-R22.5	<input type="checkbox"/>	22.5	45	80	120	240	42
BE-R23	<input type="checkbox"/>	23.0	46	80	120	240	42
BE-R24	<input type="checkbox"/>	24.0	48	80	120	240	42
BE-R25	<input type="checkbox"/>	25.0	50	80	120	240	42

### 先むく／付け刃 ボールエンドミル

### BE-A形

●2枚刃



### 付け刃 ボールエンドミル

### LS-BE形

●2枚刃、ロングシャンク

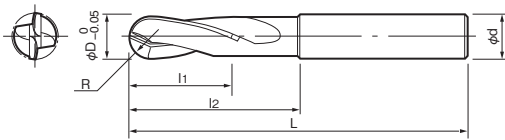
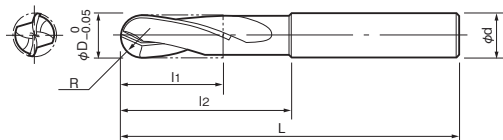

材種：K種超硬合金

形状	形番 Cat. No.	在庫 Stock		寸法 (mm) Dimensions (mm)						
		K種	M種	R	φD	l <sub>1</sub>	l <sub>2</sub>	L	φd	
先むく	R2×100	<input type="checkbox"/>		2	4	9	17	100	10	
	R2.5×120	<input type="checkbox"/>		2.5	5	10	20	120	10	
	R3×120	<input type="checkbox"/>		3	6	11	22	120	10	
	R3.5×120	<input type="checkbox"/>		3.5	7	14	27	120	10	
	R4×120	<input type="checkbox"/>		4	8	14	28	120	12	
R4.5×120	<input type="checkbox"/>		4.5	9	14	30	120	12		
付け刃	R5×120	<input type="checkbox"/>	<input type="checkbox"/>	5	10	30	48	120	10	
	R5.5×120	<input type="checkbox"/>	<input type="checkbox"/>	5.5	11	30	48	120	10	
	R6×120	<input type="checkbox"/>	<input type="checkbox"/>	6	12	30	48	120	12	
	R6.5×120	<input type="checkbox"/>	<input type="checkbox"/>	6.5	13	30	48	120	12	
	R7×120	<input type="checkbox"/>	<input type="checkbox"/>	7	14	40	48	120	12	
	R7.5×120	<input type="checkbox"/>	<input type="checkbox"/>	7.5	15	40	48	120	16	
	R8×160	<input type="checkbox"/>	<input type="checkbox"/>	8	16	50	70	160	16	
	R8.5×160	<input type="checkbox"/>	<input type="checkbox"/>	8.5	17	50	70	160	16	
	R9×160	<input type="checkbox"/>	<input type="checkbox"/>	9	18	50	70	160	16	
	R9.5×160	<input type="checkbox"/>	<input type="checkbox"/>	9.5	19	50	70	160	20	
	R10×160	<input type="checkbox"/>	<input type="checkbox"/>	10	20	60	70	160	20	
	R10.5×160	<input type="checkbox"/>	<input type="checkbox"/>	10.5	21	60	70	160	20	
	R11×160	<input type="checkbox"/>	<input type="checkbox"/>	11	22	60	70	160	20	
	R11.5×200	<input type="checkbox"/>		11.5	23	60	100	200	25	
	R12×200	<input type="checkbox"/>	<input type="checkbox"/>	12	24	60	100	200	25	
	R12.5×200	<input type="checkbox"/>	<input type="checkbox"/>	12.5	25	60	100	200	25	
	R13×200	<input type="checkbox"/>	<input type="checkbox"/>	13	26	60	100	200	25	
	R14×200	<input type="checkbox"/>	<input type="checkbox"/>	14	28	60	100	200	25	
	R15×200	<input type="checkbox"/>	<input type="checkbox"/>	15	30	60	100	200	25	
	R16×220	<input type="checkbox"/>	<input type="checkbox"/>	16	32	60	112	220	32	
	R17×220	<input type="checkbox"/>	<input type="checkbox"/>	17	34	70	112	220	32	
	R17.5×220	<input type="checkbox"/>	<input type="checkbox"/>	17.5	35	70	112	220	32	
	R18×220	<input type="checkbox"/>	<input type="checkbox"/>	18	36	70	112	220	32	
	R19×220	<input type="checkbox"/>	<input type="checkbox"/>	19	38	80	112	220	32	
	R20×220	<input type="checkbox"/>	<input type="checkbox"/>	20	40	80	112	220	32	
R21×240	<input type="checkbox"/>		21	42	80	120	240	42		
R22×240	<input type="checkbox"/>	<input type="checkbox"/>	22	44	80	120	240	42		
R22.5×240	<input type="checkbox"/>		22.5	45	80	120	240	42		
R23×240	<input type="checkbox"/>		23	46	80	120	240	42		
R24×240	<input type="checkbox"/>	<input type="checkbox"/>	24	48	80	120	240	42		
R25×240	<input type="checkbox"/>	<input type="checkbox"/>	25	50	80	120	240	42		

形番 Cat. No.	在庫 Stock	寸法 (mm) Dimensions (mm)					
		R	φD	l <sub>1</sub>	l <sub>2</sub>	L	φd
LS-BE-R5	<input type="checkbox"/>	5.0	10	30	70	200	12
LS-BE-R6	<input type="checkbox"/>	6.0	12	30	70	200	12
LS-BE-R7	<input type="checkbox"/>	7.0	14	40	70	200	16
LS-BE-R7.5	<input type="checkbox"/>	7.5	15	40	70	200	16
LS-BE-R8	<input type="checkbox"/>	8.0	16	50	100	250	16
LS-BE-R9	<input type="checkbox"/>	9.0	18	50	100	250	20
LS-BE-R10	<input type="checkbox"/>	10.0	20	60	120	300	20
LS-BE-R11	<input type="checkbox"/>	11.0	22	60	120	300	25
LS-BE-R12	<input type="checkbox"/>	12.0	24	60	120	300	25
LS-BE-R12.5	<input type="checkbox"/>	12.5	25	60	120	300	25
LS-BE-R13	<input type="checkbox"/>	13.0	26	60	120	300	25
LS-BE-R14	<input type="checkbox"/>	14.0	28	60	120	300	25
LS-BE-R15	<input type="checkbox"/>	15.0	30	60	120	300	32
LS-BE-R16	<input type="checkbox"/>	16.0	32	60	120	350	32
LS-BE-R18	<input type="checkbox"/>	18.0	36	70	120	350	32
LS-BE-R20	<input type="checkbox"/>	20.0	40	80	150	350	42
LS-BE-R22	<input type="checkbox"/>	22.0	44	80	150	350	42
LS-BE-R22.5	<input type="checkbox"/>	22.5	45	80	150	350	42
LS-BE-R23	<input type="checkbox"/>	23.0	46	80	150	350	42
LS-BE-R24	<input type="checkbox"/>	24.0	48	80	150	350	42
LS-BE-R25	<input type="checkbox"/>	25.0	50	80	150	350	42



# 先むく／付け刃 ボールエンドミル

## LS-BE形

●2枚刃、ロングシャンク

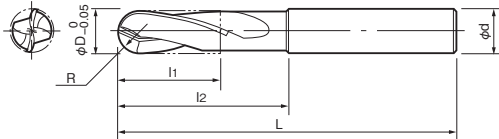

形状	形番	在庫		寸法 (mm)					
		超微粒子	M種	R	φD	l <sub>1</sub>	l <sub>2</sub>	L	φd
先むく	LS-BE-R2	<input type="checkbox"/>		2	4	20	21.3	60	6
	LS-BE-R2.5	<input type="checkbox"/>		2.5	5	25	26.2	70	6
	LS-BE-R3	<input type="checkbox"/>		3	6	25	—	70	6
	LS-BE-R3.5	<input type="checkbox"/>		3.5	7	25	26.2	70	8
	LS-BE-R4	<input type="checkbox"/>		4	8	25	—	90	8
	LS-BE-R4.5	<input type="checkbox"/>		4.5	9	25	26.2	100	10
付け刃	LS-BE-R5	<input type="checkbox"/>		5	10	30	48	130	12
	LS-BE-R5.5	<input type="checkbox"/>		5.5	11	30	48	130	12
	LS-BE-R6	<input type="checkbox"/>		6	12	30	48	150	12
	LS-BE-R6.5	<input type="checkbox"/>		6.5	13	30	48	150	16
	LS-BE-R7	<input type="checkbox"/>		7	14	40	48	150	16
	LS-BE-R7.5	<input type="checkbox"/>		7.5	15	40	48	150	16
	LS-BE-R8	<input type="checkbox"/>		8	16	50	70	180	16
	LS-BE-R8.5	<input type="checkbox"/>		8.5	17	50	70	180	20
	LS-BE-R9	<input type="checkbox"/>		9	18	50	70	180	20
	LS-BE-R9.5	<input type="checkbox"/>		9.5	19	50	70	180	20
	LS-BE-R10	<input type="checkbox"/>		10	20	60	70	200	20
	LS-BE-R11	<input type="checkbox"/>		11	22	60	70	200	25
	LS-BE-R12	<input type="checkbox"/>		12	24	60	100	220	25
	LS-BE-R12.5	<input type="checkbox"/>		12.5	25	60	100	220	25
	LS-BE-R13	<input type="checkbox"/>		13	26	60	100	220	25
	LS-BE-R14	<input type="checkbox"/>		14	28	60	100	240	25
	LS-BE-R15	<input type="checkbox"/>		15	30	60	100	240	32
	LS-BE-R16	<input type="checkbox"/>		16	32	60	112	240	32
	LS-BE-R17	<input type="checkbox"/>		17	34	70	112	260	32
	LS-BE-R17.5	<input type="checkbox"/>		17.5	35	70	112	260	32
	LS-BE-R18	<input type="checkbox"/>		18	36	70	112	260	32
	LS-BE-R19	<input type="checkbox"/>		19	38	70	112	260	32
	LS-BE-R20	<input type="checkbox"/>		20	40	80	112	280	42
	LS-BE-R22	<input type="checkbox"/>		22	44	80	120	280	42
	LS-BE-R22.5	<input type="checkbox"/>		22.5	45	80	120	280	42
LS-BE-R23	<input type="checkbox"/>		23	46	80	120	280	42	
LS-BE-R24	<input type="checkbox"/>		24	48	80	120	300	42	
LS-BE-R25	<input type="checkbox"/>		25	50	80	120	300	42	

# Vポイントドリル

# VSD形 TIN-VSD形

●φ16未満はソリッド  
●φ16以上は先むく



\*写真はJCコートを示す

注)アルミ合金の切削は、刃先部ホーニング加工しているため不向きです。

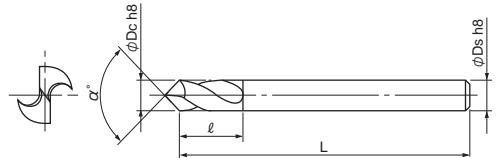

材質：JCコート(TIN系)、K種

形番	在庫 K種 ソリッド	α°	寸法 (mm)			
			φDc	ℓ	L	φDs
VSD-030-90°	<input type="checkbox"/>	90°	3	8	50	3
VSD-040-90°	<input type="checkbox"/>		4	10	50	4
VSD-050-90°	<input type="checkbox"/>		5	13	60	5
VSD-060-90°	<input type="checkbox"/>		6	15	70	6
VSD-080-90°	<input type="checkbox"/>		8	20	80	8
VSD-100-90°	<input type="checkbox"/>		10	25	90	10
VSD-120-90°	<input type="checkbox"/>		12	27	100	12
VSD-160-90°	<input type="checkbox"/>		16	40	145	16
VSD-200-90°	<input type="checkbox"/>		20	50	165	20
VSD-250-90°	<input type="checkbox"/>		25	60	180	25
VSD-030-120°	<input type="checkbox"/>	120°	3	8	50	3
VSD-040-120°	<input type="checkbox"/>		4	10	50	4
VSD-050-120°	<input type="checkbox"/>		5	13	60	5
VSD-060-120°	<input type="checkbox"/>		6	15	70	6
VSD-080-120°	<input type="checkbox"/>		8	20	80	8
VSD-100-120°	<input type="checkbox"/>		10	25	90	10
VSD-120-120°	<input type="checkbox"/>		12	27	100	12
VSD-160-120°	<input type="checkbox"/>		16	40	145	16
VSD-200-120°	<input type="checkbox"/>		20	50	165	20
VSD-250-120°	<input type="checkbox"/>		25	60	180	25

形番	在庫 JCコート (TIN系)	α°	寸法 (mm)				
			φDc	ℓ	L	φDs	
TIN-VSD-030-90°	<input type="checkbox"/>	90°	3	8	50	3	
TIN-VSD-040-90°	<input type="checkbox"/>		4	10	50	4	
TIN-VSD-050-90°	<input type="checkbox"/>		5	13	60	5	
TIN-VSD-060-90°	<input type="checkbox"/>		6	15	70	6	
TIN-VSD-080-90°	<input type="checkbox"/>		8	20	80	8	
TIN-VSD-100-90°	<input type="checkbox"/>		10	25	90	10	
TIN-VSD-120-90°	<input type="checkbox"/>		12	27	100	12	
TIN-VSD-030-120°	<input type="checkbox"/>		120°	3	8	50	3
TIN-VSD-040-120°	<input type="checkbox"/>			4	10	50	4
TIN-VSD-050-120°	<input type="checkbox"/>			5	13	60	5
TIN-VSD-060-120°	<input type="checkbox"/>	6		15	70	6	
TIN-VSD-080-120°	<input type="checkbox"/>	8		20	80	8	
TIN-VSD-100-120°	<input type="checkbox"/>	10		25	90	10	
TIN-VSD-120-120°	<input type="checkbox"/>	12		27	100	12	

# Vポイントドリル

## VSDL形 TIN-VSDL形

- φ16未満はソリッド
- φ16以上は先むく



※写真はJCコートを示す

注)アルミ合金の切削は、刃先部ホーニング加工しているため不向きです。

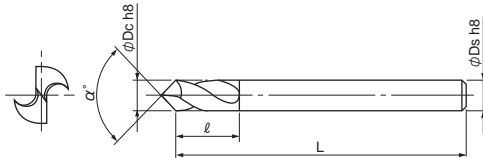

材種：JCコート(TIN系)、K種

形番	在庫		寸法(mm)			
	K種 ノンコート	α°	φDc	ℓ	L	φDs
VSDL-030-90°	<input type="checkbox"/>	90°	3	8	100	3
VSDL-040-90°	<input type="checkbox"/>		4	10	100	4
VSDL-050-90°	<input type="checkbox"/>		5	13	110	5
VSDL-060-90°	<input type="checkbox"/>		6	15	120	6
VSDL-080-90°	<input type="checkbox"/>		8	20	140	8
VSDL-100-90°	<input type="checkbox"/>		10	25	160	10
VSDL-120-90°	<input type="checkbox"/>		12	27	180	12
VSDL-160-90°	<input type="checkbox"/>		16	40	230	16
VSDL-200-90°	<input type="checkbox"/>		20	50	250	20
VSDL-250-90°	<input type="checkbox"/>		25	60	280	25
VSDL-030-120°	<input type="checkbox"/>	120°	3	8	100	3
VSDL-040-120°	<input type="checkbox"/>		4	10	100	4
VSDL-050-120°	<input type="checkbox"/>		5	13	110	5
VSDL-060-120°	<input type="checkbox"/>		6	15	120	6
VSDL-080-120°	<input type="checkbox"/>		8	20	140	8
VSDL-100-120°	<input type="checkbox"/>		10	25	160	10
VSDL-120-120°	<input type="checkbox"/>		12	27	180	12
VSDL-160-120°	<input type="checkbox"/>		16	40	230	16
VSDL-200-120°	<input type="checkbox"/>		20	50	250	20
VSDL-250-120°	<input type="checkbox"/>		25	60	280	25

形番	在庫		寸法(mm)			
	JCコート (TIN系)	α°	φDc	ℓ	L	φDs
TIN-VSDL-030-90°	<input type="checkbox"/>	90°	3	8	100	3
TIN-VSDL-040-90°	<input type="checkbox"/>		4	10	100	4
TIN-VSDL-050-90°	<input type="checkbox"/>		5	13	110	5
TIN-VSDL-060-90°	<input type="checkbox"/>		6	15	120	6
TIN-VSDL-080-90°	<input type="checkbox"/>		8	20	140	8
TIN-VSDL-100-90°	<input type="checkbox"/>		10	25	160	10
TIN-VSDL-120-90°	<input type="checkbox"/>		12	27	180	12
TIN-VSDL-160-90°	<input type="checkbox"/>		16	40	230	16
TIN-VSDL-200-90°	<input type="checkbox"/>		20	50	250	20
TIN-VSDL-250-90°	<input type="checkbox"/>		25	60	280	25
TIN-VSDL-030-120°	<input type="checkbox"/>	120°	3	8	100	3
TIN-VSDL-040-120°	<input type="checkbox"/>		4	10	100	4
TIN-VSDL-050-120°	<input type="checkbox"/>		5	13	110	5
TIN-VSDL-060-120°	<input type="checkbox"/>		6	15	120	6
TIN-VSDL-080-120°	<input type="checkbox"/>		8	20	140	8
TIN-VSDL-100-120°	<input type="checkbox"/>		10	25	160	10
TIN-VSDL-120-120°	<input type="checkbox"/>		12	27	180	12
TIN-VSDL-160-120°	<input type="checkbox"/>		16	40	230	16
TIN-VSDL-200-120°	<input type="checkbox"/>		20	50	250	20
TIN-VSDL-250-120°	<input type="checkbox"/>		25	60	280	25

351

# 先むくテーパシャンクツイストドリル

# DTD形

- 豊富な再研磨回数で高い経済性を有する
- 鋳鉄・非鉄金属用

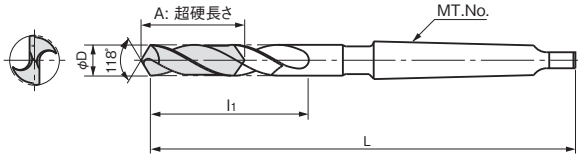

材種：K種超硬合金

■外径寸法許容差 (mm)

工具径φD	Tool dia.φD	許容差 Tolerance
5.0以上6.0以下	5.0 Over 6.0 Up to	0 -0.018
6.0をこえ10.0以下	6.0 Over 10.0 Up to	0 -0.022
10.0をこえ18.0以下	10.0 Over 18.0 Up to	0 -0.027
18.0をこえ30.0以下	18.0 Over 30.0 Up to	0 -0.033
30.0をこえ40.0以下	30.0 Over 40.0 Up to	0 -0.039

形番 Cat. No.	在庫 Stock	寸法 (mm) Dimensions (mm)				シャンク MT.No.
		φD	li	L	A	
DTD-050	□	5.0	65	145	32	MT1
DTD-051	□	5.1	65	145	32	MT1
DTD-052	□	5.2	65	145	32	MT1
DTD-053	□	5.3	65	145	32	MT1
DTD-054	□	5.4	65	145	32	MT1
DTD-055	□	5.5	65	145	32	MT1
DTD-056	□	5.6	68	148	32	MT1
DTD-057	□	5.7	68	148	32	MT1
DTD-058	□	5.8	68	148	32	MT1
DTD-059	□	5.9	68	148	32	MT1
DTD-060×MT1	●	6.0	68	148	32	MT1
DTD-061	□	6.1	72	152	32	MT1
DTD-062	□	6.2	72	152	32	MT1
DTD-063	□	6.3	72	152	32	MT1
DTD-064	□	6.4	72	152	32	MT1
DTD-065×MT1	●	6.5	72	152	32	MT1
DTD-066	□	6.6	75	155	37	MT1
DTD-067	□	6.7	75	155	37	MT1
DTD-068	□	6.8	75	155	37	MT1
DTD-069	□	6.9	75	155	37	MT1
DTD-070×MT1	●	7.0	75	155	37	MT1
DTD-071	□	7.1	78	158	37	MT1
DTD-072	□	7.2	78	158	37	MT1
DTD-073	□	7.3	78	158	37	MT1
DTD-074	□	7.4	78	158	37	MT1
DTD-075×MT1	●	7.5	78	158	37	MT1
DTD-076	□	7.6	82	162	37	MT1
DTD-077	□	7.7	82	162	37	MT1
DTD-078	□	7.8	82	162	37	MT1
DTD-079	□	7.9	82	162	37	MT1
DTD-080×MT1	●	8.0	82	162	37	MT1
DTD-081	□	8.1	85	168	37	MT1
DTD-082	□	8.2	85	168	37	MT1
DTD-083	□	8.3	85	168	37	MT1
DTD-084	□	8.4	85	168	37	MT1
DTD-085×MT1	●	8.5	85	168	37	MT1
DTD-086	□	8.6	88	172	37	MT1
DTD-087	□	8.7	88	172	37	MT1
DTD-088	□	8.8	88	172	37	MT1
DTD-089	□	8.9	88	172	37	MT1
DTD-090×MT1	●	9.0	88	172	37	MT1
DTD-091	□	9.1	92	175	37	MT1
DTD-092	□	9.2	92	175	37	MT1

形番 Cat. No.	在庫 Stock	寸法 (mm) Dimensions (mm)				シャンク MT.No.
		φD	li	L	A	
DTD-093	□	9.3	92	175	37	MT1
DTD-094	□	9.4	92	175	37	MT1
DTD-095×MT1	●	9.5	92	175	37	MT1
DTD-096	□	9.6	95	178	37	MT1
DTD-097	□	9.7	95	178	37	MT1
DTD-098	□	9.8	95	178	37	MT1
DTD-099	□	9.9	95	178	37	MT1
DTD-100×MT1	●	10.0	95	178	37	MT1
DTD-101	□	10.1	98	182	43	MT1
DTD-102	□	10.2	98	182	43	MT1
DTD-103	□	10.3	98	182	43	MT1
DTD-104	□	10.4	98	182	43	MT1
DTD-105×MT1	●	10.5	98	182	43	MT1
DTD-106	□	10.6	102	185	43	MT1
DTD-107	□	10.7	102	185	43	MT1
DTD-108	□	10.8	102	185	43	MT1
DTD-109	□	10.9	102	185	43	MT1
DTD-110×MT1	●	11.0	102	185	43	MT1
DTD-111	□	11.1	105	188	43	MT1
DTD-112	□	11.2	105	188	43	MT1
DTD-113	□	11.3	105	188	43	MT1
DTD-114	□	11.4	105	188	43	MT1
DTD-115×MT1	●	11.5	105	188	43	MT1
DTD-116	□	11.6	108	192	43	MT1
DTD-117	□	11.7	108	192	43	MT1
DTD-118	□	11.8	108	192	43	MT1
DTD-119	□	11.9	108	192	43	MT1
DTD-120×MT1	●	12.0	108	192	43	MT1
DTD-121	□	12.1	112	195	43	MT1
DTD-122	□	12.2	112	195	43	MT1
DTD-123	□	12.3	112	195	43	MT1
DTD-124	□	12.4	112	195	43	MT1
DTD-125×MT1	●	12.5	112	195	43	MT1
DTD-126	□	12.6	115	198	43	MT1
DTD-127	□	12.7	115	198	43	MT1
DTD-128	□	12.8	115	198	43	MT1
DTD-129	□	12.9	115	198	43	MT1
DTD-130×MT1	●	13.0	115	198	43	MT1
DTD-131	□	13.1	118	202	49	MT1
DTD-132	□	13.2	118	202	49	MT1
DTD-133	□	13.3	118	202	49	MT1
DTD-134	□	13.4	118	202	49	MT1
DTD-135×MT1	●	13.5	118	202	49	MT1

35471

## 先むくテーパシャンクツイストドリル

## DTD形

(前ページの続き)

形番 Cat. No.	在庫 Stock	寸法 (mm) Dimensions (mm)				シャンク MT.No
		φD	l <sub>1</sub>	L	A	
DTD-135×MT2	●	13.5	118	218	49	MT2
DTD-136	□	13.6	122	205	49	MT1
DTD-137	□	13.7	122	205	49	MT1
DTD-138	□	13.8	122	205	49	MT1
DTD-139	□	13.9	122	205	49	MT1
DTD-140×MT1	●	14.0	122	205	49	MT1
DTD-140×MT2	●	14.0	122	222	49	MT2
DTD-141	□	14.1	122	222	49	MT2
DTD-142	□	14.2	122	222	49	MT2
DTD-143	□	14.3	122	222	49	MT2
DTD-144	□	14.4	122	222	49	MT2
DTD-145×MT2	●	14.5	122	222	49	MT2
DTD-146	□	14.6	125	225	49	MT2
DTD-147	□	14.7	125	225	49	MT2
DTD-148	□	14.8	125	225	49	MT2
DTD-149	□	14.9	125	225	49	MT2
DTD-150×MT2	●	15.0	125	225	49	MT2
DTD-151	□	15.1	128	228	49	MT2
DTD-152	□	15.2	128	228	49	MT2
DTD-153	□	15.3	128	228	49	MT2
DTD-154	□	15.4	128	228	49	MT2
DTD-155×MT2	●	15.5	128	228	49	MT2
DTD-156	□	15.6	130	230	49	MT2
DTD-157	□	15.7	130	230	49	MT2
DTD-158	□	15.8	130	230	49	MT2
DTD-159	□	15.9	130	230	49	MT2
DTD-160×MT2	●	16.0	130	230	49	MT2
DTD-161	□	16.1	132	232	49	MT2
DTD-162	□	16.2	132	232	49	MT2
DTD-163	□	16.3	132	232	49	MT2
DTD-164	□	16.4	132	232	49	MT2
DTD-165×MT2	●	16.5	132	232	49	MT2
DTD-166	□	16.6	135	235	49	MT2
DTD-167	□	16.7	135	235	49	MT2
DTD-168	□	16.8	135	235	49	MT2
DTD-169	□	16.9	135	235	49	MT2
DTD-170×MT2	●	17.0	135	235	49	MT2
DTD-171	□	17.1	140	240	49	MT2
DTD-172	□	17.2	140	240	49	MT2
DTD-173	□	17.3	140	240	49	MT2
DTD-174	□	17.4	140	240	49	MT2
DTD-175×MT2	●	17.5	140	240	49	MT2
DTD-176	□	17.6	140	240	49	MT2
DTD-177	□	17.7	140	240	49	MT2
DTD-178	□	17.8	140	240	49	MT2
DTD-179	□	17.9	140	240	49	MT2
DTD-180×MT2	●	18.0	140	240	49	MT2
DTD-181	□	18.1	145	245	54	MT2
DTD-182	□	18.2	145	245	54	MT2
DTD-183	□	18.3	145	245	54	MT2
DTD-184	□	18.4	145	245	54	MT2
DTD-185×MT2	●	18.5	145	245	54	MT2
DTD-186	□	18.6	145	245	54	MT2

形番 Cat. No.	在庫 Stock	寸法 (mm) Dimensions (mm)				シャンク MT.No
		φD	l <sub>1</sub>	L	A	
DTD-187	□	18.7	145	245	54	MT2
DTD-188	□	18.8	145	245	54	MT2
DTD-189	□	18.9	145	245	54	MT2
DTD-190×MT2	●	19.0	145	245	54	MT2
DTD-191	□	19.1	150	250	54	MT2
DTD-192	□	19.2	150	250	54	MT2
DTD-193	□	19.3	150	250	54	MT2
DTD-194	□	19.4	150	250	54	MT2
DTD-195×MT2	●	19.5	150	250	54	MT2
DTD-196	□	19.6	150	250	54	MT2
DTD-197	□	19.7	150	250	54	MT2
DTD-198	□	19.8	150	250	54	MT2
DTD-199	□	19.9	150	250	54	MT2
DTD-200×MT2	●	20.0	150	250	54	MT2
DTD-201	□	20.1	155	255	54	MT2
DTD-202	□	20.2	155	255	54	MT2
DTD-203	□	20.3	155	255	54	MT2
DTD-204	□	20.4	155	255	54	MT2
DTD-205	□	20.5	155	255	54	MT2
DTD-206	□	20.6	155	255	54	MT2
DTD-207	□	20.7	155	255	54	MT2
DTD-208	□	20.8	155	255	54	MT2
DTD-209	□	20.9	155	255	54	MT2
DTD-210	□	21.0	155	255	54	MT2
DTD-215	□	21.5	160	260	59	MT2
DTD-220	□	22.0	160	260	59	MT2
DTD-225	□	22.5	165	265	59	MT2
DTD-230	□	23.0	165	265	59	MT2
DTD-235	□	23.5	165	285	59	MT3
DTD-240	□	24.0	165	285	64	MT3
DTD-245	□	24.5	165	285	64	MT3
DTD-250×MT3	●	25.0	165	285	64	MT3
DTD-255	□	25.5	165	285	59	MT3
DTD-260	□	26.0	165	285	59	MT3
DTD-265	□	26.5	170	290	59	MT3
DTD-270	□	27.0	170	290	59	MT3
DTD-275	□	27.5	175	295	59	MT3
DTD-280	□	28.0	175	295	59	MT3
DTD-285	□	28.5	180	300	59	MT3
DTD-290	□	29.0	180	300	59	MT3
DTD-295	□	29.5	185	305	59	MT3
DTD-300	□	30.0	185	305	59	MT3
DTD-310×MT3	□	31.0	190	310	48	MT3
DTD-320×MT3	□	32.0	195	315	48	MT3
DTD-330×MT4	□	33.0	200	345	48	MT4
DTD-340×MT4	□	34.0	205	350	48	MT4
DTD-350×MT4	□	35.0	205	350	48.5	MT4
DTD-360×MT4	□	36.0	210	355	49	MT4
DTD-370×MT4	□	37.0	210	355	49	MT4
DTD-380×MT4	□	38.0	215	360	53	MT4
DTD-390×MT4	□	39.0	215	360	54	MT4
DTD-400×MT4	□	40.0	220	365	54	MT4

35471

# 先むくテーパシャンクツイストドリル

# DTDL形

● 鋳鉄、非鉄金属用

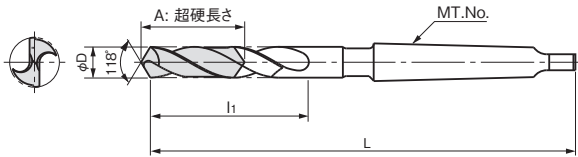

材種：K種

■ 外径寸法許容差 (mm)

工具径φD	Tool dia.φD	許容差 Tolerance
5.0以上6.0以下	5.0 Over 6.0 Up to	0 -0.018
6.0をこえ10.0以下	6.0 Over 10.0 Up to	0 -0.022
10.0をこえ18.0以下	10.0 Over 18.0 Up to	0 -0.027
18.0をこえ30.0以下	18.0 Over 30.0 Up to	0 -0.033
30.0をこえ40.0以下	30.0 Over 40.0 Up to	0 -0.039

形番 Cat. No.	在庫 Stock	寸法 (mm) Dimensions (mm)				シャンク MT.No.
		φD	l <sub>1</sub>	L	A	
DTDL-060-250-150	<input type="checkbox"/>	6	150	250	32	MT1
DTDL-065-250-150	<input type="checkbox"/>	6.5	150	250	32	MT1
DTDL-070-250-150	<input type="checkbox"/>	7	150	250	37	MT1
DTDL-075-250-150	<input type="checkbox"/>	7.5	150	250	37	MT1
DTDL-080-250-150	<input type="checkbox"/>	8	150	250	37	MT1
DTDL-085-250-150	<input type="checkbox"/>	8.5	150	250	37	MT1
DTDL-090-250-150	<input type="checkbox"/>	9	150	250	37	MT1
DTDL-095-250-150	<input type="checkbox"/>	9.5	150	250	37	MT1
DTDL-100-250-150	<input type="checkbox"/>	10	150	250	37	MT1
DTDL-100-300-200	<input type="checkbox"/>	10	200	300	37	MT1
DTDL-105-250-150	<input type="checkbox"/>	10.5	150	250	43	MT1
DTDL-105-300-200	<input type="checkbox"/>	10.5	200	300	43	MT1
DTDL-110-250-150	<input type="checkbox"/>	11	150	250	43	MT1
DTDL-110-300-200	<input type="checkbox"/>	11	200	300	43	MT1
DTDL-115-250-150	<input type="checkbox"/>	11.5	150	250	43	MT1
DTDL-115-300-200	<input type="checkbox"/>	11.5	200	300	43	MT1
DTDL-120-250-150	<input type="checkbox"/>	12	150	250	43	MT1
DTDL-120-300-200	<input type="checkbox"/>	12	200	300	43	MT1
DTDL-125-250-150	<input type="checkbox"/>	12.5	150	250	43	MT1
DTDL-125-300-200	<input type="checkbox"/>	12.5	200	300	43	MT1
DTDL-130-250-150	<input type="checkbox"/>	13	150	250	43	MT1
DTDL-130-300-200	<input type="checkbox"/>	13	200	300	43	MT1
DTDL-135-250-150	<input type="checkbox"/>	13.5	150	250	49	MT1
DTDL-135-300-200	<input type="checkbox"/>	13.5	200	300	49	MT1
DTDL-140-250-150	<input type="checkbox"/>	14	150	250	49	MT1
DTDL-140-300-200	<input type="checkbox"/>	14	200	300	49	MT1
DTDL-145-250-150	<input type="checkbox"/>	14.5	150	250	49	MT2
DTDL-145-300-200	<input type="checkbox"/>	14.5	200	300	49	MT2
DTDL-150-250-150	<input type="checkbox"/>	15	150	250	49	MT2
DTDL-150-300-200	<input type="checkbox"/>	15	200	300	49	MT2
DTDL-150-350-200	<input type="checkbox"/>	15	200	350	49	MT2
DTDL-150-350-250	<input type="checkbox"/>	15	250	350	49	MT2
DTDL-155-300-200	<input type="checkbox"/>	15.5	200	300	49	MT2
DTDL-155-350-200	<input type="checkbox"/>	15.5	200	350	49	MT2
DTDL-160-300-200	<input type="checkbox"/>	16	200	300	49	MT2
DTDL-160-350-200	<input type="checkbox"/>	16	200	350	49	MT2
DTDL-160-350-250	<input type="checkbox"/>	16	250	350	49	MT2
DTDL-165-300-200	<input type="checkbox"/>	16.5	200	300	49	MT2
DTDL-165-350-200	<input type="checkbox"/>	16.5	200	350	49	MT2
DTDL-170-300-200	<input type="checkbox"/>	17	200	300	49	MT2
DTDL-170-350-200	<input type="checkbox"/>	17	200	350	49	MT2
DTDL-170-350-250	<input type="checkbox"/>	17	250	350	49	MT2
DTDL-175-300-200	<input type="checkbox"/>	17.5	200	300	49	MT2

形番 Cat. No.	在庫 Stock	寸法 (mm) Dimensions (mm)				シャンク MT.No.
		φD	l <sub>1</sub>	L	A	
DTDL-175-350-200	<input type="checkbox"/>	17.5	200	350	49	MT2
DTDL-180-300-200	<input type="checkbox"/>	18	200	300	49	MT2
DTDL-180-350-200	<input type="checkbox"/>	18	200	350	49	MT2
DTDL-180-350-250	<input type="checkbox"/>	18	250	350	49	MT2
DTDL-185-300-200	<input type="checkbox"/>	18.5	200	300	54	MT2
DTDL-185-350-200	<input type="checkbox"/>	18.5	200	350	54	MT2
DTDL-190-300-200	<input type="checkbox"/>	19	200	300	54	MT2
DTDL-190-350-200	<input type="checkbox"/>	19	200	350	54	MT2
DTDL-190-350-250	<input type="checkbox"/>	19	250	350	54	MT2
DTDL-190-400-300	<input type="checkbox"/>	19	300	400	54	MT2
DTDL-195-300-200	<input type="checkbox"/>	19.5	200	300	54	MT2
DTDL-195-350-200	<input type="checkbox"/>	19.5	200	350	54	MT2
DTDL-200-300-200	<input type="checkbox"/>	20	200	300	54	MT2
DTDL-200-350-200	<input type="checkbox"/>	20	200	350	54	MT2
DTDL-200-350-250	<input type="checkbox"/>	20	250	350	54	MT2
DTDL-200-400-300	<input type="checkbox"/>	20	300	400	54	MT2
DTDL-200-450-350	<input type="checkbox"/>	20	350	450	54	MT2
DTDL-205-350-200	<input type="checkbox"/>	20.5	200	350	54	MT2
DTDL-205-400-300	<input type="checkbox"/>	20.5	300	400	54	MT2
DTDL-210-350-200	<input type="checkbox"/>	21	200	350	54	MT2
DTDL-210-350-250	<input type="checkbox"/>	21	250	350	54	MT2
DTDL-210-400-300	<input type="checkbox"/>	21	300	400	54	MT2
DTDL-210-450-350	<input type="checkbox"/>	21	350	450	54	MT2
DTDL-215-350-200	<input type="checkbox"/>	21.5	200	350	59	MT2
DTDL-215-400-300	<input type="checkbox"/>	21.5	300	400	59	MT2
DTDL-220-350-200	<input type="checkbox"/>	22	200	350	59	MT2
DTDL-220-350-250	<input type="checkbox"/>	22	250	350	59	MT2
DTDL-220-400-300	<input type="checkbox"/>	22	300	400	59	MT2
DTDL-220-450-350	<input type="checkbox"/>	22	350	450	59	MT2
DTDL-225-350-200	<input type="checkbox"/>	22.5	200	350	59	MT2
DTDL-225-400-300	<input type="checkbox"/>	22.5	300	400	59	MT2
DTDL-230-350-200	<input type="checkbox"/>	23	200	350	59	MT2
DTDL-230-350-250	<input type="checkbox"/>	23	250	350	59	MT2
DTDL-230-400-300	<input type="checkbox"/>	23	300	400	59	MT2
DTDL-230-450-350	<input type="checkbox"/>	23	350	450	59	MT2
DTDL-235-350-200	<input type="checkbox"/>	23.5	200	350	59	MT3
DTDL-235-400-300	<input type="checkbox"/>	23.5	300	400	59	MT2
DTDL-240-350-200	<input type="checkbox"/>	24	200	350	64	MT3
DTDL-240-400-250	<input type="checkbox"/>	24	250	400	64	MT3
DTDL-240-450-300	<input type="checkbox"/>	24	300	450	64	MT3
DTDL-240-500-350	<input type="checkbox"/>	24	350	500	64	MT3
DTDL-245-350-200	<input type="checkbox"/>	24.5	200	350	64	MT3
DTDL-245-400-250	<input type="checkbox"/>	24.5	250	400	64	MT3





## 先むくドリル

## TOP-SLD形

● 鋳鉄用、先むく



## 付け刃テーパシャンクドリル TD形

● 鋳鉄用、テーパシャンク、付け刃

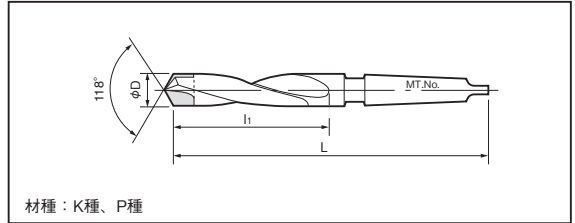
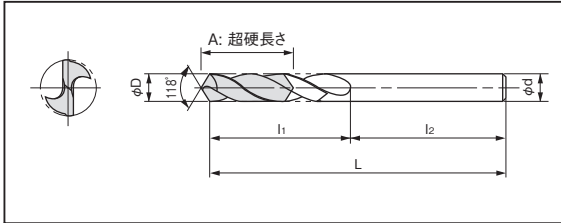

材種：K種、P種

形番 Cat. No.	在庫 Stock	寸法 (mm) Dimensions (mm)					
		φD	L	l <sub>1</sub>	l <sub>2</sub>	d	A
TOP-SLD-060	<input type="checkbox"/>	6					
TOP-SLD-065	<input type="checkbox"/>	6.5					
TOP-SLD-070	<input type="checkbox"/>	7	120	65	45	8	73
TOP-SLD-075	<input type="checkbox"/>	7.5					
TOP-SLD-080	<input type="checkbox"/>	8			60		
TOP-SLD-085	<input type="checkbox"/>	8.5	140	80			89
TOP-SLD-090	<input type="checkbox"/>	9			50		
TOP-SLD-095	<input type="checkbox"/>	9.5				10	99
TOP-SLD-100	<input type="checkbox"/>	10			60		
TOP-SLD-105	<input type="checkbox"/>	10.5	150	90			
TOP-SLD-110	<input type="checkbox"/>	11			50		100
TOP-SLD-115	<input type="checkbox"/>	11.5					
TOP-SLD-120	<input type="checkbox"/>	12			65		105
TOP-SLD-125	<input type="checkbox"/>	12.5	160	95		12	106
TOP-SLD-130	<input type="checkbox"/>	13			55		
TOP-SLD-135	<input type="checkbox"/>	13.5					107
TOP-SLD-140	<input type="checkbox"/>	14					
TOP-SLD-145	<input type="checkbox"/>	14.5	170	100	60		112
TOP-SLD-150	<input type="checkbox"/>	15					
TOP-SLD-155	<input type="checkbox"/>	15.5					113
TOP-SLD-160	<input type="checkbox"/>	16			80	16	
TOP-SLD-165	<input type="checkbox"/>	16.5	190	110			35
TOP-SLD-170	<input type="checkbox"/>	17					
TOP-SLD-175	<input type="checkbox"/>	17.5					
TOP-SLD-180	<input type="checkbox"/>	18			70		
TOP-SLD-185	<input type="checkbox"/>	18.5					
TOP-SLD-190	<input type="checkbox"/>	19	210	130			
TOP-SLD-195	<input type="checkbox"/>	19.5					
TOP-SLD-200	<input type="checkbox"/>	20			80	20	38
TOP-SLD-205	<input type="checkbox"/>	20.5					
TOP-SLD-210	<input type="checkbox"/>	21					
TOP-SLD-215	<input type="checkbox"/>	21.5	230	150			
TOP-SLD-220	<input type="checkbox"/>	22					
TOP-SLD-225	<input type="checkbox"/>	22.5			70		42
TOP-SLD-230	<input type="checkbox"/>	23					
TOP-SLD-235	<input type="checkbox"/>	23.5					
TOP-SLD-240	<input type="checkbox"/>	24	250	170			
TOP-SLD-245	<input type="checkbox"/>	24.5					45
TOP-SLD-250	<input type="checkbox"/>	25			80		

24

形番 Cat. No.	在庫 Stock		寸法 (mm) Dimensions (mm)			シャンク MT. No.
	K種	P種	φD	l <sub>1</sub>	L	
TD-060	<input type="checkbox"/>	<input type="checkbox"/>	6	30	110	MT1
TD-061~064	<input type="checkbox"/>	<input type="checkbox"/>	6.1~6.4	40	120	MT1
TD-065	<input type="checkbox"/>	<input type="checkbox"/>	6.5	40	120	MT1
TD-066~069	<input type="checkbox"/>	<input type="checkbox"/>	6.6~6.9	40	120	MT1
TD-070	<input type="checkbox"/>	<input type="checkbox"/>	7	40	120	MT1
TD-071~074	<input type="checkbox"/>	<input type="checkbox"/>	7.1~7.4	40	120	MT1
TD-075	<input type="checkbox"/>	<input type="checkbox"/>	7.5	40	120	MT1
TD-076~079	<input type="checkbox"/>	<input type="checkbox"/>	7.6~7.9	40	120	MT1
TD-080	<input type="checkbox"/>	<input type="checkbox"/>	8	40	120	MT1
TD-081~084	<input type="checkbox"/>	<input type="checkbox"/>	8.1~8.4	50	130	MT1
TD-085	<input type="checkbox"/>	<input type="checkbox"/>	8.5	50	130	MT1
TD-086~089	<input type="checkbox"/>	<input type="checkbox"/>	8.6~8.9	50	130	MT1
TD-090	<input type="checkbox"/>	<input type="checkbox"/>	9	50	130	MT1
TD-091~094	<input type="checkbox"/>	<input type="checkbox"/>	9.1~9.4	60	140	MT1
TD-095	<input type="checkbox"/>	<input type="checkbox"/>	9.5	60	140	MT1
TD-096~099	<input type="checkbox"/>	<input type="checkbox"/>	9.6~9.9	60	140	MT1
TD-100	<input type="checkbox"/>	<input type="checkbox"/>	10	60	140	MT1
TD-101~104	<input type="checkbox"/>	<input type="checkbox"/>	10.1~10.4	70	150	MT1
TD-105	<input type="checkbox"/>	<input type="checkbox"/>	10.5	70	150	MT1
TD-106~109	<input type="checkbox"/>	<input type="checkbox"/>	10.6~10.9	70	150	MT1
TD-110	<input type="checkbox"/>	<input type="checkbox"/>	11	70	150	MT1
TD-111~114	<input type="checkbox"/>	<input type="checkbox"/>	11.1~11.4	70	150	MT1
TD-115	<input type="checkbox"/>	<input type="checkbox"/>	11.5	70	150	MT1
TD-116~119	<input type="checkbox"/>	<input type="checkbox"/>	11.6~11.9	70	150	MT1
TD-120	<input type="checkbox"/>	<input type="checkbox"/>	12	70	150	MT1
TD-121~124	<input type="checkbox"/>	<input type="checkbox"/>	12.1~12.4	80	160	MT1
TD-125	<input type="checkbox"/>	<input type="checkbox"/>	12.5	80	160	MT1
TD-126~129	<input type="checkbox"/>	<input type="checkbox"/>	12.6~12.9	80	160	MT1
TD-130	<input type="checkbox"/>	<input type="checkbox"/>	13	80	160	MT1
TD-131~134	<input type="checkbox"/>	<input type="checkbox"/>	13.1~13.4	80	160	MT1
TD-135	<input type="checkbox"/>	<input type="checkbox"/>	13.5	80	160	MT1
TD-136~139	<input type="checkbox"/>	<input type="checkbox"/>	13.6~13.9	80	160	MT1
TD-140	<input type="checkbox"/>	<input type="checkbox"/>	14	80	160	MT1
TD-141~144	<input type="checkbox"/>	<input type="checkbox"/>	14.1~14.4	100	200	MT2
TD-145	<input type="checkbox"/>	<input type="checkbox"/>	14.5	100	200	MT2
TD-146~149	<input type="checkbox"/>	<input type="checkbox"/>	14.6~14.9	100	200	MT2
TD-150	<input type="checkbox"/>	<input type="checkbox"/>	15	100	200	MT2
TD-151~154	<input type="checkbox"/>	<input type="checkbox"/>	15.1~15.4	100	200	MT2
TD-155	<input type="checkbox"/>	<input type="checkbox"/>	15.5	100	200	MT2
TD-156~159	<input type="checkbox"/>	<input type="checkbox"/>	15.6~15.9	100	200	MT2
TD-160	<input type="checkbox"/>	<input type="checkbox"/>	16	100	200	MT2
TD-161~164	<input type="checkbox"/>	<input type="checkbox"/>	16.1~16.4	100	200	MT2
TD-165	<input type="checkbox"/>	<input type="checkbox"/>	16.5	100	200	MT2

947561



# 付け刃テーパシャンクドリル

# TD形

(前ページの続き)

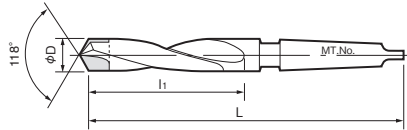

材種：K種、P種

形番 Cat. No.	在庫 Stock		寸法 (mm) Dimensions (mm)			シャンク MT. No.	形番 Cat. No.	在庫 Stock		寸法 (mm) Dimensions (mm)			シャンク MT. No.
	K種	P種	φD	l1	L			K種	P種	φD	l1	L	
TD-166~169	<input type="checkbox"/>	<input type="checkbox"/>	16.6~16.9	100	200	MT2	TD-340	<input type="checkbox"/>	<input type="checkbox"/>	34	180	330	MT4
TD-170	<input type="checkbox"/>	<input type="checkbox"/>	17	100	200	MT2	TD-345	<input type="checkbox"/>	<input type="checkbox"/>	34.5	180	330	MT4
TD-171~174	<input type="checkbox"/>	<input type="checkbox"/>	17.1~17.4	100	200	MT2	TD-350	<input type="checkbox"/>	<input type="checkbox"/>	35	180	330	MT4
TD-175	<input type="checkbox"/>	<input type="checkbox"/>	17.5	100	200	MT2	TD-355	<input type="checkbox"/>	<input type="checkbox"/>	35.5	190	340	MT4
TD-176~179	<input type="checkbox"/>	<input type="checkbox"/>	17.6~17.9	100	200	MT2	TD-360	<input type="checkbox"/>	<input type="checkbox"/>	36	190	340	MT4
TD-180	<input type="checkbox"/>	<input type="checkbox"/>	18	100	200	MT2	TD-365	<input type="checkbox"/>	<input type="checkbox"/>	36.5	190	340	MT4
TD-181~184	<input type="checkbox"/>	<input type="checkbox"/>	18.1~18.4	110	210	MT2	TD-370	<input type="checkbox"/>	<input type="checkbox"/>	37	190	340	MT4
TD-185	<input type="checkbox"/>	<input type="checkbox"/>	18.5	110	210	MT2	TD-375	<input type="checkbox"/>	<input type="checkbox"/>	37.5	190	340	MT4
TD-186~189	<input type="checkbox"/>	<input type="checkbox"/>	18.6~18.9	110	210	MT2	TD-380	<input type="checkbox"/>	<input type="checkbox"/>	38	190	340	MT4
TD-190	<input type="checkbox"/>	<input type="checkbox"/>	19	110	210	MT2	TD-385	<input type="checkbox"/>	<input type="checkbox"/>	38.5	190	340	MT4
TD-191~194	<input type="checkbox"/>	<input type="checkbox"/>	19.1~19.4	110	210	MT2	TD-390	<input type="checkbox"/>	<input type="checkbox"/>	39	190	340	MT4
TD-195	<input type="checkbox"/>	<input type="checkbox"/>	19.5	110	210	MT2	TD-395	<input type="checkbox"/>	<input type="checkbox"/>	39.5	190	340	MT4
TD-196~199	<input type="checkbox"/>	<input type="checkbox"/>	19.6~19.9	110	210	MT2	TD-400	<input type="checkbox"/>	<input type="checkbox"/>	40	190	340	MT4
TD-200	<input type="checkbox"/>	<input type="checkbox"/>	20	110	210	MT2	TD-405	<input type="checkbox"/>	<input type="checkbox"/>	40.5	200	350	MT4
TD-201~209	<input type="checkbox"/>	<input type="checkbox"/>	20.1~20.9	110	210	MT2	TD-410	<input type="checkbox"/>	<input type="checkbox"/>	41	200	350	MT4
TD-210	<input type="checkbox"/>	<input type="checkbox"/>	21	110	210	MT2	TD-420	<input type="checkbox"/>	<input type="checkbox"/>	42	200	350	MT4
TD-211~219	<input type="checkbox"/>	<input type="checkbox"/>	21.1~21.9	120	220	MT2	TD-430	<input type="checkbox"/>	<input type="checkbox"/>	43	200	350	MT4
TD-220	<input type="checkbox"/>	<input type="checkbox"/>	22	120	220	MT2	TD-435	<input type="checkbox"/>	<input type="checkbox"/>	43.5	200	350	MT4
TD-221~229	<input type="checkbox"/>	<input type="checkbox"/>	22.1~22.9	120	220	MT2	TD-440	<input type="checkbox"/>	<input type="checkbox"/>	44	200	350	MT4
TD-230	<input type="checkbox"/>	<input type="checkbox"/>	23	120	220	MT2	TD-450	<input type="checkbox"/>	<input type="checkbox"/>	45	200	350	MT4
TD-231~239	<input type="checkbox"/>	<input type="checkbox"/>	23.1~23.9	130	250	MT3	TD-460	<input type="checkbox"/>	<input type="checkbox"/>	46	210	360	MT4
TD-240	<input type="checkbox"/>	<input type="checkbox"/>	24	130	250	MT3	TD-470	<input type="checkbox"/>	<input type="checkbox"/>	47	210	360	MT4
TD-241~249	<input type="checkbox"/>	<input type="checkbox"/>	24.1~24.9	130	250	MT3	TD-480	<input type="checkbox"/>	<input type="checkbox"/>	48	210	360	MT4
TD-250	<input type="checkbox"/>	<input type="checkbox"/>	25	130	250	MT3	TD-490	<input type="checkbox"/>	<input type="checkbox"/>	49	210	360	MT4
TD-251~259	<input type="checkbox"/>	<input type="checkbox"/>	25.1~25.9	130	250	MT3	TD-500	<input type="checkbox"/>	<input type="checkbox"/>	50	210	360	MT4
TD-260	<input type="checkbox"/>	<input type="checkbox"/>	26	130	250	MT3							
TD-261~269	<input type="checkbox"/>	<input type="checkbox"/>	26.1~26.9	140	260	MT3							
TD-270	<input type="checkbox"/>	<input type="checkbox"/>	27	140	260	MT3							
TD-271~279	<input type="checkbox"/>	<input type="checkbox"/>	27.1~27.9	140	260	MT3							
TD-280	<input type="checkbox"/>	<input type="checkbox"/>	28	140	260	MT3							
TD-281~289	<input type="checkbox"/>	<input type="checkbox"/>	28.1~28.9	140	260	MT3							
TD-290	<input type="checkbox"/>	<input type="checkbox"/>	29	140	260	MT3							
TD-291~294	<input type="checkbox"/>	<input type="checkbox"/>	29.1~29.4	150	270	MT3							
TD-295	<input type="checkbox"/>	<input type="checkbox"/>	29.5	150	270	MT3							
TD-296~299	<input type="checkbox"/>	<input type="checkbox"/>	29.6~29.9	150	270	MT3							
TD-300	<input type="checkbox"/>	<input type="checkbox"/>	30	150	270	MT3							
TD-305	<input type="checkbox"/>	<input type="checkbox"/>	30.5	150	270	MT3							
TD-310	<input type="checkbox"/>	<input type="checkbox"/>	31	150	270	MT3							
TD-315	<input type="checkbox"/>	<input type="checkbox"/>	31.5	150	270	MT3							
TD-320	<input type="checkbox"/>	<input type="checkbox"/>	32	150	270	MT3							
TD-325	<input type="checkbox"/>	<input type="checkbox"/>	32.5	180	330	MT4							
TD-330	<input type="checkbox"/>	<input type="checkbox"/>	33	180	330	MT4							
TD-335	<input type="checkbox"/>	<input type="checkbox"/>	33.5	180	330	MT4							

947561

# 付け刃ストレートシャンクドリル

# SD形

● 鋳鉄用、付け刃

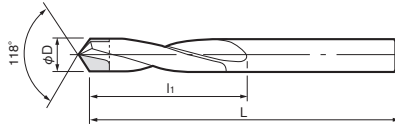

材種：K種超硬合金

■ 外径寸法許容差 (mm)

工具径φD	Tool dia.φD	許容差 Tolerance
3以下	3 Up to	$0$ -0.014
3をこえ6以下	3 Over 6 Up to	$0$ -0.018
6をこえ10以下	6 Over 10 Up to	$0$ -0.022
10をこえ13以下	10 Over 13 Up to	$0$ -0.027

形番				寸法 (mm)				形番				寸法 (mm)				形番				寸法 (mm)			
Cat. No.		在庫	Dimensions (mm)			Cat. No.		在庫	Dimensions (mm)			Cat. No.		在庫	Dimensions (mm)			Cat. No.		在庫	Dimensions (mm)		
		Stock	φD	l <sub>1</sub>	L			Stock	φD	l <sub>1</sub>	L			Stock	φD	l <sub>1</sub>	L			Stock	φD	l <sub>1</sub>	L
SD-030		<input type="checkbox"/>	3	20	62	SD-068		<input type="checkbox"/>	6.8	40	80	SD-106		<input type="checkbox"/>	10.6	55	100						
SD-031		<input type="checkbox"/>	3.1	25	62	SD-069		<input type="checkbox"/>	6.9	40	80	SD-107		<input type="checkbox"/>	10.7	55	100						
SD-032		<input type="checkbox"/>	3.2	25	62	SD-070		<input type="checkbox"/>	7	40	80	SD-108		<input type="checkbox"/>	10.8	55	100						
SD-033		<input type="checkbox"/>	3.3	25	62	SD-071		<input type="checkbox"/>	7.1	40	80	SD-109		<input type="checkbox"/>	10.9	55	100						
SD-034		<input type="checkbox"/>	3.4	25	62	SD-072		<input type="checkbox"/>	7.2	40	80	SD-110		<input type="checkbox"/>	11	55	100						
SD-035		<input type="checkbox"/>	3.5	25	62	SD-073		<input type="checkbox"/>	7.3	40	80	SD-111		<input type="checkbox"/>	11.1	62	112						
SD-036		<input type="checkbox"/>	3.6	25	62	SD-074		<input type="checkbox"/>	7.4	40	80	SD-112		<input type="checkbox"/>	11.2	62	112						
SD-037		<input type="checkbox"/>	3.7	25	62	SD-075		<input type="checkbox"/>	7.5	40	80	SD-113		<input type="checkbox"/>	11.3	62	112						
SD-038		<input type="checkbox"/>	3.8	25	62	SD-076		<input type="checkbox"/>	7.6	40	80	SD-114		<input type="checkbox"/>	11.4	62	112						
SD-039		<input type="checkbox"/>	3.9	25	62	SD-077		<input type="checkbox"/>	7.7	40	80	SD-115		<input type="checkbox"/>	11.5	62	112						
SD-040		<input type="checkbox"/>	4	25	62	SD-078		<input type="checkbox"/>	7.8	40	80	SD-116		<input type="checkbox"/>	11.6	62	112						
SD-041		<input type="checkbox"/>	4.1	28	62	SD-079		<input type="checkbox"/>	7.9	40	80	SD-117		<input type="checkbox"/>	11.7	62	112						
SD-042		<input type="checkbox"/>	4.2	28	62	SD-080		<input type="checkbox"/>	8	40	80	SD-118		<input type="checkbox"/>	11.8	62	112						
SD-043		<input type="checkbox"/>	4.3	28	62	SD-081		<input type="checkbox"/>	8.1	50	90	SD-119		<input type="checkbox"/>	11.9	62	112						
SD-044		<input type="checkbox"/>	4.4	28	62	SD-082		<input type="checkbox"/>	8.2	50	90	SD-120		<input type="checkbox"/>	12	62	112						
SD-045		<input type="checkbox"/>	4.5	28	62	SD-083		<input type="checkbox"/>	8.3	50	90	SD-121		<input type="checkbox"/>	12.1	62	112						
SD-046		<input type="checkbox"/>	4.6	28	62	SD-084		<input type="checkbox"/>	8.4	50	90	SD-122		<input type="checkbox"/>	12.2	62	112						
SD-047		<input type="checkbox"/>	4.7	28	62	SD-085		<input type="checkbox"/>	8.5	50	90	SD-123		<input type="checkbox"/>	12.3	62	112						
SD-048		<input type="checkbox"/>	4.8	28	62	SD-086		<input type="checkbox"/>	8.6	50	90	SD-124		<input type="checkbox"/>	12.4	62	112						
SD-049		<input type="checkbox"/>	4.9	28	62	SD-087		<input type="checkbox"/>	8.7	50	90	SD-125		<input type="checkbox"/>	12.5	62	112						
SD-050		<input type="checkbox"/>	5	28	62	SD-088		<input type="checkbox"/>	8.8	50	90	SD-126		<input type="checkbox"/>	12.6	62	112						
SD-051		<input type="checkbox"/>	5.1	32	70	SD-089		<input type="checkbox"/>	8.9	50	90	SD-127		<input type="checkbox"/>	12.7	62	112						
SD-052		<input type="checkbox"/>	5.2	32	70	SD-090		<input type="checkbox"/>	9	50	90	SD-128		<input type="checkbox"/>	12.8	62	112						
SD-053		<input type="checkbox"/>	5.3	32	70	SD-091		<input type="checkbox"/>	9.1	50	90	SD-129		<input type="checkbox"/>	12.9	62	112						
SD-054		<input type="checkbox"/>	5.4	32	70	SD-092		<input type="checkbox"/>	9.2	50	90	SD-130		<input type="checkbox"/>	13	62	112						
SD-055		<input type="checkbox"/>	5.5	32	70	SD-093		<input type="checkbox"/>	9.3	50	90												
SD-056		<input type="checkbox"/>	5.6	32	70	SD-094		<input type="checkbox"/>	9.4	50	90												
SD-057		<input type="checkbox"/>	5.7	32	70	SD-095		<input type="checkbox"/>	9.5	50	90												
SD-058		<input type="checkbox"/>	5.8	32	70	SD-096		<input type="checkbox"/>	9.6	55	100												
SD-059		<input type="checkbox"/>	5.9	32	70	SD-097		<input type="checkbox"/>	9.7	55	100												
SD-060		<input type="checkbox"/>	6	32	70	SD-098		<input type="checkbox"/>	9.8	55	100												
SD-061		<input type="checkbox"/>	6.1	32	70	SD-099		<input type="checkbox"/>	9.9	55	100												
SD-062		<input type="checkbox"/>	6.2	32	70	SD-100		<input type="checkbox"/>	10	55	100												
SD-063		<input type="checkbox"/>	6.3	32	70	SD-101		<input type="checkbox"/>	10.1	55	100												
SD-064		<input type="checkbox"/>	6.4	32	70	SD-102		<input type="checkbox"/>	10.2	55	100												
SD-065		<input type="checkbox"/>	6.5	32	70	SD-103		<input type="checkbox"/>	10.3	55	100												
SD-066		<input type="checkbox"/>	6.6	40	80	SD-104		<input type="checkbox"/>	10.4	55	100												
SD-067		<input type="checkbox"/>	6.7	40	80	SD-105		<input type="checkbox"/>	10.5	55	100												

654

# ソリッドメタルソー

# SDM形

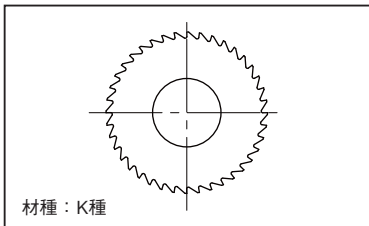

材種：K種

■穴径φ15.875

形番 Cat. No.	在庫 Stock	寸法 (mm) Dimensions (mm)			刃数 N
		外径 D	厚み L	穴径 d	
SDM-45-03	□	45	0.3	15.875	38
SDM-45-04	□	45	0.4	15.875	38
SDM-45-05	□	45	0.5	15.875	38
SDM-45-06	□	45	0.6	15.875	38
SDM-45-07	□	45	0.7	15.875	38
SDM-45-08	□	45	0.8	15.875	38
SDM-45-09	□	45	0.9	15.875	34
SDM-45-10	□	45	1	15.875	34
SDM-45-12	□	45	1.2	15.875	34
SDM-45-15	□	45	1.5	15.875	34
SDM-45-16	□	45	1.6	15.875	34
SDM-45-18	□	45	1.8	15.875	34
SDM-45-20	□	45	2	15.875	34
SDM-50-03	□	50	0.3	15.875	40
SDM-50-04	□	50	0.4	15.875	40
SDM-50-05	□	50	0.5	15.875	40
SDM-50-06	□	50	0.6	15.875	40
SDM-50-07	□	50	0.7	15.875	40
SDM-50-08	□	50	0.8	15.875	40
SDM-50-09	□	50	0.9	15.875	40
SDM-50-10	□	50	1	15.875	36
SDM-50-12	□	50	1.2	15.875	36
SDM-50-15	□	50	1.5	15.875	36
SDM-50-16	□	50	1.6	15.875	36
SDM-50-18	□	50	1.8	15.875	36
SDM-50-20	□	50	2	15.875	36

■穴径φ25.4

形番 Cat. No.	在庫 Stock	寸法 (mm) Dimensions (mm)			刃数 N
		外径 D	厚み L	穴径 d	
SDM-60-03	□	60	0.3	25.4	40
SDM-60-04	□	60	0.4	25.4	40
SDM-60-05	□	60	0.5	25.4	40
SDM-60-06	□	60	0.6	25.4	40
SDM-60-07	□	60	0.7	25.4	40
SDM-60-08	□	60	0.8	25.4	40
SDM-60-09	□	60	0.9	25.4	40
SDM-60-10	□	60	1	25.4	36
SDM-60-12	□	60	1.2	25.4	36
SDM-60-15	□	60	1.5	25.4	36
SDM-60-16	□	60	1.6	25.4	36
SDM-60-18	□	60	1.8	25.4	36
SDM-60-20	□	60	2	25.4	36
SDM-75-02	□	75	0.2	25.4	48
SDM-75-03	□	75	0.3	25.4	48
SDM-75-04	□	75	0.4	25.4	48
SDM-75-05	□	75	0.5	25.4	48
SDM-75-06	□	75	0.6	25.4	48
SDM-75-07	□	75	0.7	25.4	48
SDM-75-08	□	75	0.8	25.4	48
SDM-75-09	□	75	0.9	25.4	48
SDM-75-10	□	75	1	25.4	42
SDM-75-11	□	75	1.1	25.4	42
SDM-75-12	□	75	1.2	25.4	42
SDM-75-13	□	75	1.3	25.4	42
SDM-75-14	□	75	1.4	25.4	42
SDM-75-15	□	75	1.5	25.4	42
SDM-75-16	□	75	1.6	25.4	42
SDM-75-17	□	75	1.7	25.4	42
SDM-75-18	□	75	1.8	25.4	42
SDM-75-19	□	75	1.9	25.4	42
SDM-75-20	□	75	2	25.4	42
SDM-75-25	□	75	2.5	25.4	42
SDM-75-30	□	75	3	25.4	42
SDM-100-05	□	100	0.5	25.4	72
SDM-100-06	□	100	0.6	25.4	72
SDM-100-07	□	100	0.7	25.4	72
SDM-100-08	□	100	0.8	25.4	72

形番 Cat. No.	在庫 Stock	寸法 (mm) Dimensions (mm)			刃数 N
		外径 D	厚み L	穴径 d	
SDM-100-09	□	100	0.9	25.4	72
SDM-100-10	□	100	1	25.4	72
SDM-100-11	□	100	1.1	25.4	72
SDM-100-12	□	100	1.2	25.4	72
SDM-100-13	□	100	1.3	25.4	72
SDM-100-14	□	100	1.4	25.4	72
SDM-100-15	□	100	1.5	25.4	56
SDM-100-16	□	100	1.6	25.4	56
SDM-100-17	□	100	1.7	25.4	56
SDM-100-18	□	100	1.8	25.4	56
SDM-100-19	□	100	1.9	25.4	56
SDM-100-20	□	100	2	25.4	56
SDM-100-25	□	100	2.5	25.4	56
SDM-100-30	□	100	3	25.4	56
SDM-125-10	□	125	1	25.4	90
SDM-125-12	□	125	1.2	25.4	90
SDM-125-15	□	125	1.5	25.4	90
SDM-125-16	□	125	1.6	25.4	90
SDM-125-18	□	125	1.8	25.4	90
SDM-125-20	□	125	2	25.4	90
SDM-125-25	□	125	2.5	25.4	90
SDM-125-30	□	125	3	25.4	90

# ソリッドフライスカッタ

# SDFM形

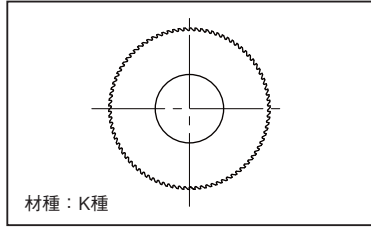

外径 D	穴径 d	厚さ W		刃数 N	在庫	外径 D	穴径 d	厚さ W		刃数 N	在庫	外径 D	穴径 d	厚さ W		刃数 N	在庫
		寸法 Dimensions	許容差 Tolerance					寸法 Dimensions	許容差 Tolerance					寸法 Dimensions	許容差 Tolerance		
20 +0.2 0	6.0 +0.012 0	±0.01	60	0.10	<input type="checkbox"/>	30 +0.2 0	6.0 +0.012 0	±0.01	60	0.20	<input type="checkbox"/>	45 +0.2 0	12.7 +0.012 0	±0.01	90	0.25	<input type="checkbox"/>
				0.15	<input type="checkbox"/>					0.25	<input type="checkbox"/>					0.30	<input type="checkbox"/>
				0.20	<input type="checkbox"/>					0.30	<input type="checkbox"/>					0.35	<input type="checkbox"/>
				0.25	<input type="checkbox"/>					0.35	<input type="checkbox"/>					0.40	<input type="checkbox"/>
				0.30	<input type="checkbox"/>					0.40	<input type="checkbox"/>					0.45	<input type="checkbox"/>
				0.35	<input type="checkbox"/>					0.45	<input type="checkbox"/>					0.50	<input type="checkbox"/>
				0.40	<input type="checkbox"/>					0.50	<input type="checkbox"/>					0.55	<input type="checkbox"/>
				0.45	<input type="checkbox"/>					0.55	<input type="checkbox"/>					0.60	<input type="checkbox"/>
				0.50	<input type="checkbox"/>					0.60	<input type="checkbox"/>					0.65	<input type="checkbox"/>
				0.60	<input type="checkbox"/>					0.65	<input type="checkbox"/>					0.70	<input type="checkbox"/>
				0.70	<input type="checkbox"/>					0.70	<input type="checkbox"/>					0.75	<input type="checkbox"/>
				0.80	<input type="checkbox"/>					0.75	<input type="checkbox"/>					0.80	<input type="checkbox"/>
				0.90	<input type="checkbox"/>					0.80	<input type="checkbox"/>					0.85	<input type="checkbox"/>
				1.00	<input type="checkbox"/>					0.85	<input type="checkbox"/>					0.90	<input type="checkbox"/>
				1.10	<input type="checkbox"/>					0.90	<input type="checkbox"/>					0.95	<input type="checkbox"/>
				1.20	<input type="checkbox"/>					0.95	<input type="checkbox"/>					1.00	<input type="checkbox"/>
				1.30	<input type="checkbox"/>					1.00	<input type="checkbox"/>					1.05	<input type="checkbox"/>
				1.40	<input type="checkbox"/>					1.05	<input type="checkbox"/>					1.10	<input type="checkbox"/>
				1.50	<input type="checkbox"/>					1.10	<input type="checkbox"/>					1.15	<input type="checkbox"/>
1.60	<input type="checkbox"/>	1.15	<input type="checkbox"/>	1.20	<input type="checkbox"/>												
1.70	<input type="checkbox"/>	1.20	<input type="checkbox"/>	1.25	<input type="checkbox"/>												
1.80	<input type="checkbox"/>	1.25	<input type="checkbox"/>	1.30	<input type="checkbox"/>												
1.90	<input type="checkbox"/>	1.30	<input type="checkbox"/>	1.35	<input type="checkbox"/>												
2.00	<input type="checkbox"/>	1.35	<input type="checkbox"/>	1.40	<input type="checkbox"/>												
25 +0.2 0	6.0 +0.012 0	±0.01	60	0.10	<input type="checkbox"/>	45 +0.2 0	12.7 +0.012 0	±0.01	90	1.40	<input type="checkbox"/>	45 +0.2 0	12.7 +0.012 0	±0.01	90	1.45	<input type="checkbox"/>
				0.20	<input type="checkbox"/>					1.45	<input type="checkbox"/>					1.50	<input type="checkbox"/>
				0.30	<input type="checkbox"/>					1.50	<input type="checkbox"/>					1.55	<input type="checkbox"/>
				0.40	<input type="checkbox"/>					1.55	<input type="checkbox"/>					1.60	<input type="checkbox"/>
				0.50	<input type="checkbox"/>					1.60	<input type="checkbox"/>					1.65	<input type="checkbox"/>
				0.60	<input type="checkbox"/>					1.65	<input type="checkbox"/>					1.70	<input type="checkbox"/>
				0.70	<input type="checkbox"/>					1.70	<input type="checkbox"/>					1.75	<input type="checkbox"/>
				0.80	<input type="checkbox"/>					1.75	<input type="checkbox"/>					1.80	<input type="checkbox"/>
				0.90	<input type="checkbox"/>					1.80	<input type="checkbox"/>					1.85	<input type="checkbox"/>
				1.00	<input type="checkbox"/>					1.85	<input type="checkbox"/>					1.90	<input type="checkbox"/>
				1.10	<input type="checkbox"/>					1.90	<input type="checkbox"/>					1.95	<input type="checkbox"/>
				1.20	<input type="checkbox"/>					1.95	<input type="checkbox"/>					2.00	<input type="checkbox"/>
				1.30	<input type="checkbox"/>					2.00	<input type="checkbox"/>					2.10	<input type="checkbox"/>
				1.40	<input type="checkbox"/>					2.10	<input type="checkbox"/>					2.20	<input type="checkbox"/>
				1.50	<input type="checkbox"/>					2.20	<input type="checkbox"/>					2.30	<input type="checkbox"/>
				1.60	<input type="checkbox"/>					2.30	<input type="checkbox"/>					2.40	<input type="checkbox"/>
				1.70	<input type="checkbox"/>					2.40	<input type="checkbox"/>					2.50	<input type="checkbox"/>
				1.80	<input type="checkbox"/>					2.50	<input type="checkbox"/>					2.60	<input type="checkbox"/>
				1.90	<input type="checkbox"/>					2.60	<input type="checkbox"/>					2.70	<input type="checkbox"/>
2.00	<input type="checkbox"/>	2.70	<input type="checkbox"/>	2.80	<input type="checkbox"/>												
30 +0.2 0	6.0 +0.012 0	±0.01	60	0.10	<input type="checkbox"/>	45 +0.2 0	12.7 +0.012 0	±0.01	90	0.15	<input type="checkbox"/>	45 +0.2 0	12.7 +0.012 0	±0.01	90	2.90	<input type="checkbox"/>
				0.15	<input type="checkbox"/>					0.20	<input type="checkbox"/>					3.00	<input type="checkbox"/>

SDFM形

ソリッドフライスカッタ

(前ページの続き)

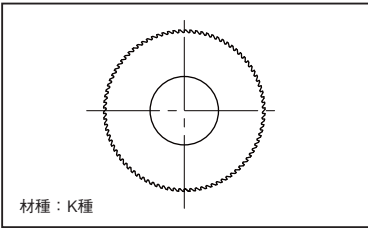

外径 D	穴径 d	厚さ W		刃数 N	在庫	外径 D	穴径 d	厚さ W		刃数 N	在庫	外径 D	穴径 d	厚さ W		刃数 N	在庫
		寸法 Dimensions	許容差 Tolerance					寸法 Dimensions	許容差 Tolerance					寸法 Dimensions	許容差 Tolerance		
45 +0.2 0	12.7 +0.012 0	0.10	±0.01	120	<input type="checkbox"/>	45 +0.2 0	15.875 +0.018 0	1.30	±0.01	90	<input type="checkbox"/>	45 +0.2 0	15.875 +0.018 0	3.00	±0.01	120	<input type="checkbox"/>
		0.20			<input type="checkbox"/>			1.35			<input type="checkbox"/>						
		0.30			<input type="checkbox"/>			1.40			<input type="checkbox"/>						
		0.40			<input type="checkbox"/>			1.45			<input type="checkbox"/>						
		0.50			<input type="checkbox"/>			1.50			<input type="checkbox"/>						
		0.60			<input type="checkbox"/>			1.55			<input type="checkbox"/>						
		0.70			<input type="checkbox"/>			1.60			<input type="checkbox"/>						
		0.80			<input type="checkbox"/>			1.65			<input type="checkbox"/>						
		0.90			<input type="checkbox"/>			1.70			<input type="checkbox"/>						
		1.00			<input type="checkbox"/>			1.75			<input type="checkbox"/>						
		1.10			<input type="checkbox"/>			1.80			<input type="checkbox"/>						
		1.20			<input type="checkbox"/>			1.85			<input type="checkbox"/>						
		1.30			<input type="checkbox"/>			1.90			<input type="checkbox"/>						
		1.40			<input type="checkbox"/>			1.95			<input type="checkbox"/>						
		1.50			<input type="checkbox"/>			2.00			<input type="checkbox"/>						
45 +0.2 0	15.875 +0.018 0	0.10	±0.01	90	<input type="checkbox"/>	45 +0.2 0	15.875 +0.018 0	0.10	±0.01	120	<input type="checkbox"/>	45 +0.2 0	15.875 +0.018 0		±0.01	120	<input type="checkbox"/>
		0.15			<input type="checkbox"/>			0.20			<input type="checkbox"/>						
		0.20			<input type="checkbox"/>			0.30			<input type="checkbox"/>						
		0.25			<input type="checkbox"/>			0.35			<input type="checkbox"/>						
		0.30			<input type="checkbox"/>			0.40			<input type="checkbox"/>						
		0.35			<input type="checkbox"/>			0.45			<input type="checkbox"/>						
		0.40			<input type="checkbox"/>			0.50			<input type="checkbox"/>						
		0.45			<input type="checkbox"/>			0.60			<input type="checkbox"/>						
		0.50			<input type="checkbox"/>			0.65			<input type="checkbox"/>						
		0.55			<input type="checkbox"/>			0.70			<input type="checkbox"/>						
		0.60			<input type="checkbox"/>			0.75			<input type="checkbox"/>						
		0.65			<input type="checkbox"/>			0.80			<input type="checkbox"/>						
		0.70			<input type="checkbox"/>			0.85			<input type="checkbox"/>						
		0.75			<input type="checkbox"/>			0.90			<input type="checkbox"/>						
		0.80			<input type="checkbox"/>			0.95			<input type="checkbox"/>						
45 +0.2 0	15.875 +0.018 0	0.85	±0.01	120	<input type="checkbox"/>	45 +0.2 0	15.875 +0.018 0	1.00	±0.01	120	<input type="checkbox"/>	45 +0.2 0	15.875 +0.018 0		±0.01	120	<input type="checkbox"/>
		0.90			<input type="checkbox"/>			1.10			<input type="checkbox"/>						
		0.95			<input type="checkbox"/>			1.20			<input type="checkbox"/>						
		1.00			<input type="checkbox"/>			1.30			<input type="checkbox"/>						
		1.05			<input type="checkbox"/>			1.40			<input type="checkbox"/>						
		1.10			<input type="checkbox"/>			1.50			<input type="checkbox"/>						
		1.15			<input type="checkbox"/>			1.60			<input type="checkbox"/>						
		1.20			<input type="checkbox"/>			1.70			<input type="checkbox"/>						
		1.25			<input type="checkbox"/>			1.80			<input type="checkbox"/>						
					<input type="checkbox"/>			1.90			<input type="checkbox"/>						
					<input type="checkbox"/>			2.00			<input type="checkbox"/>						
					<input type="checkbox"/>			2.10			<input type="checkbox"/>						
					<input type="checkbox"/>			2.20			<input type="checkbox"/>						
					<input type="checkbox"/>			2.30			<input type="checkbox"/>						
					<input type="checkbox"/>			2.40			<input type="checkbox"/>						
	<input type="checkbox"/>	2.50	<input type="checkbox"/>														

# サイドカッタ

# NDS形

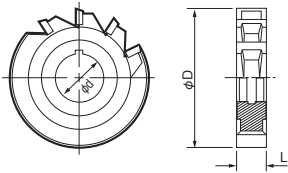

材質：K種（鋳物用）、M種（鋼用）

### ■穴径φ25.4

形番 Cat. No.	在庫 Stock	寸法 (mm) Dimensions (mm)			刃数 N
		外径 φD	刃幅 L	穴径 φd	
NDS-75-03	□	75	3	25.4	12
NDS-75-035	□	75	3.5	25.4	12
NDS-75-04	□	75	4	25.4	12
NDS-75-045	□	75	4.5	25.4	12
NDS-75-05	□	75	5	25.4	12
NDS-75-06	□	75	6	25.4	12
NDS-75-07	□	75	7	25.4	12
NDS-75-08	□	75	8	25.4	12
NDS-75-085	□	75	8.5	25.4	12
NDS-75-09	□	75	9	25.4	12
NDS-75-095	□	75	9.5	25.4	12
NDS-75-10	□	75	10	25.4	12
NDS-75-11	□	75	11	25.4	12
NDS-75-12	□	75	12	25.4	12
NDS-75-13	□	75	13	25.4	12
NDS-75-14	□	75	14	25.4	12
NDS-75-15	□	75	15	25.4	12
NDS-75-16	□	75	16	25.4	12
NDS-75-17	□	75	17	25.4	12
NDS-75-18	□	75	18	25.4	12
NDS-75-19	□	75	19	25.4	12
NDS-75-20	□	75	20	25.4	12
NDS-75-22	□	75	22	25.4	12
NDS-75-24	□	75	24	25.4	12
NDS-75-25	□	75	25	25.4	12
NDS-100-03	□	100	3	25.4	14
NDS-100-04	□	100	4	25.4	14
NDS-100-045	□	100	4.5	25.4	14
NDS-100-05	□	100	5	25.4	14
NDS-100-06	□	100	6	25.4	14
NDS-100-07	□	100	7	25.4	14
NDS-100-08	□	100	8	25.4	14
NDS-100-09	□	100	9	25.4	14
NDS-100-10	□	100	10	25.4	14
NDS-100-11	□	100	11	25.4	14
NDS-100-12	□	100	12	25.4	14
NDS-100-13	□	100	13	25.4	14
NDS-100-14	□	100	14	25.4	14
NDS-100-15	□	100	15	25.4	14
NDS-100-16	□	100	16	25.4	14
NDS-100-17	□	100	17	25.4	14

形番 Cat. No.	在庫 Stock	寸法 (mm) Dimensions (mm)			刃数 N
		外径 φD	刃幅 L	穴径 φd	
NDS-100-18	□	100	18	25.4	14
NDS-100-19	□	100	19	25.4	14
NDS-100-20	□	100	20	25.4	14
NDS-100-22	□	100	22	25.4	14
NDS-100-24	□	100	24	25.4	14
NDS-100-25	□	100	25	25.4	14
NDS-125-03	□	125	3	25.4	16
NDS-125-04	□	125	4	25.4	16
NDS-125-05	□	125	5	25.4	16
NDS-125-055	□	125	5.5	25.4	16
NDS-125-06	□	125	6	25.4	16
NDS-125-07	□	125	7	25.4	16
NDS-125-08	□	125	8	25.4	16
NDS-125-09	□	125	9	25.4	16
NDS-125-10	□	125	10	25.4	16
NDS-125-11	□	125	11	25.4	16
NDS-125-12	□	125	12	25.4	16
NDS-125-13	□	125	13	25.4	16
NDS-125-14	□	125	14	25.4	16
NDS-125-15	□	125	15	25.4	16
NDS-125-16	□	125	16	25.4	16
NDS-125-17	□	125	17	25.4	16
NDS-125-18	□	125	18	25.4	16
NDS-125-19	□	125	19	25.4	16
NDS-125-20	□	125	20	25.4	16
NDS-125-22	□	125	22	25.4	16
NDS-125-24	□	125	24	25.4	16
NDS-125-25	□	125	25	25.4	16
NDS-150-03	□	150	3	25.4	18
NDS-150-04	□	150	4	25.4	18
NDS-150-05	□	150	5	25.4	18
NDS-150-06	□	150	6	25.4	18
NDS-150-07	□	150	7	25.4	18
NDS-150-08	□	150	8	25.4	18
NDS-150-085	□	150	8.5	25.4	18
NDS-150-09	□	150	9	25.4	18
NDS-150-10	□	150	10	25.4	18
NDS-150-11	□	150	11	25.4	18
NDS-150-12	□	150	12	25.4	18
NDS-150-13	□	150	13	25.4	18
NDS-150-14	□	150	14	25.4	18
NDS-150-15	□	150	15	25.4	18
NDS-150-16	□	150	16	25.4	18
NDS-150-17	□	150	17	25.4	18
NDS-150-18	□	150	18	25.4	18
NDS-150-19	□	150	19	25.4	18
NDS-150-20	□	150	20	25.4	18
NDS-150-22	□	150	22	25.4	18
NDS-150-24	□	150	24	25.4	18
NDS-150-25	□	150	25	25.4	18
NDS-150-26	□	150	26	25.4	18
NDS-175-04	□	175	4	25.4	20
NDS-175-05	□	175	5	25.4	20
NDS-175-06	□	175	6	25.4	20
NDS-175-07	□	175	7	25.4	20

形番 Cat. No.	在庫 Stock	寸法 (mm) Dimensions (mm)			刃数 N
		外径 φD	刃幅 L	穴径 φd	
NDS-175-08	□	175	8	25.4	20
NDS-175-09	□	175	9	25.4	20
NDS-175-10	□	175	10	25.4	20
NDS-175-11	□	175	11	25.4	20
NDS-175-12	□	175	12	25.4	20
NDS-175-13	□	175	13	25.4	20
NDS-175-14	□	175	14	25.4	20
NDS-175-15	□	175	15	25.4	20
NDS-175-16	□	175	16	25.4	20
NDS-175-17	□	175	17	25.4	20
NDS-175-18	□	175	18	25.4	20
NDS-175-19	□	175	19	25.4	20
NDS-175-20	□	175	20	25.4	20
NDS-175-22	□	175	22	25.4	20
NDS-175-24	□	175	24	25.4	20
NDS-175-25	□	175	25	25.4	20
NDS-175-26	□	175	26	25.4	20
NDS-200-04	□	200	4	25.4	22
NDS-200-05	□	200	5	25.4	22
NDS-200-06	□	200	6	25.4	22
NDS-200-07	□	200	7	25.4	22
NDS-200-08	□	200	8	25.4	22
NDS-200-09	□	200	9	25.4	22
NDS-200-10	□	200	10	25.4	22
NDS-200-11	□	200	11	25.4	22
NDS-200-12	□	200	12	25.4	22
NDS-200-13	□	200	13	25.4	22
NDS-200-14	□	200	14	25.4	22
NDS-200-15	□	200	15	25.4	22
NDS-200-16	□	200	16	25.4	22
NDS-200-17	□	200	17	25.4	22
NDS-200-18	□	200	18	25.4	22
NDS-200-19	□	200	19	25.4	22
NDS-200-20	□	200	20	25.4	22
NDS-200-22	□	200	22	25.4	22
NDS-200-24	□	200	24	25.4	22
NDS-200-25	□	200	25	25.4	22
NDS-200-26	□	200	26	25.4	22
NDS-250-06	□	250	6	25.5	26
NDS-250-08	□	250	8	25.4	26
NDS-250-09	□	250	9	25.4	26
NDS-250-10	□	250	10	25.4	26
NDS-250-11	□	250	11	25.4	26
NDS-250-12	□	250	12	25.4	26
NDS-250-13	□	250	13	25.4	26
NDS-250-14	□	250	14	25.4	26
NDS-250-15	□	250	15	25.4	26
NDS-250-16	□	250	16	25.4	26
NDS-250-18	□	250	18	25.4	26
NDS-250-20	□	250	20	25.4	26
NDS-250-22	□	250	22	25.4	26
NDS-250-24	□	250	24	25.4	26
NDS-250-25	□	250	25	25.4	26
NDS-250-26	□	250	26	25.4	26
NDS-250-30	□	250	30	25.4	26



# サイドカッタ

# NDS形

(前ページの続き)

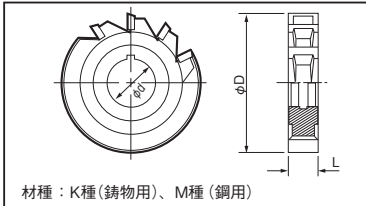

材質：K種(鋳物用)、M種(鋼用)

## ■穴径φ25.4

形番 Cat. No.	在庫 Stock	寸法 (mm) Dimensions (mm)			刃数 N
		外径 φD	刃幅 L	穴径 φd	
NDS-75- <sup>3</sup> / <sub>16</sub>	□	75	4.7625	25.4	12
NDS-75- <sup>1</sup> / <sub>4</sub>	□	75	6.35	25.4	12
NDS-75- <sup>5</sup> / <sub>16</sub>	□	75	7.9375	25.4	12
NDS-75- <sup>3</sup> / <sub>8</sub>	□	75	9.525	25.4	12
NDS-75- <sup>7</sup> / <sub>16</sub>	□	75	11.1125	25.4	12
NDS-75- <sup>1</sup> / <sub>2</sub>	□	75	12.7	25.4	12
NDS-75- <sup>9</sup> / <sub>16</sub>	□	75	14.2875	25.4	12
NDS-75- <sup>5</sup> / <sub>8</sub>	□	75	15.875	25.4	12
NDS-75- <sup>11</sup> / <sub>16</sub>	□	75	17.4625	25.4	12
NDS-100- <sup>3</sup> / <sub>16</sub>	□	100	4.7625	25.4	14
NDS-100- <sup>1</sup> / <sub>4</sub>	□	100	6.35	25.4	14
NDS-100- <sup>5</sup> / <sub>16</sub>	□	100	7.9375	25.4	14
NDS-100- <sup>3</sup> / <sub>8</sub>	□	100	9.525	25.4	14
NDS-100- <sup>1</sup> / <sub>2</sub>	□	100	12.7	25.4	14
NDS-100- <sup>9</sup> / <sub>16</sub>	□	100	14.2875	25.4	14
NDS-100- <sup>5</sup> / <sub>8</sub>	□	100	15.875	25.4	14
NDS-100- <sup>11</sup> / <sub>16</sub>	□	100	17.4625	25.4	14
NDS-125- <sup>3</sup> / <sub>16</sub>	□	125	4.7625	25.4	16
NDS-125- <sup>1</sup> / <sub>4</sub>	□	125	6.35	25.4	16
NDS-125- <sup>5</sup> / <sub>16</sub>	□	125	7.9375	25.4	16
NDS-125- <sup>3</sup> / <sub>8</sub>	□	125	9.525	25.4	16
NDS-125- <sup>7</sup> / <sub>16</sub>	□	125	11.1125	25.4	16
NDS-125- <sup>9</sup> / <sub>16</sub>	□	125	14.2875	25.4	16
NDS-125- <sup>5</sup> / <sub>8</sub>	□	125	15.875	25.4	16
NDS-125- <sup>3</sup> / <sub>4</sub>	□	125	19.05	25.4	16
NDS-125- <sup>7</sup> / <sub>8</sub>	□	125	22.225	25.4	16
NDS-150- <sup>1</sup> / <sub>4</sub>	□	150	6.35	25.4	18
NDS-150- <sup>5</sup> / <sub>16</sub>	□	150	7.9375	25.4	18
NDS-150- <sup>3</sup> / <sub>8</sub>	□	150	9.525	25.4	18
NDS-150- <sup>1</sup> / <sub>2</sub>	□	150	12.7	25.4	18
NDS-150- <sup>11</sup> / <sub>16</sub>	□	150	17.4625	25.4	18
NDS-150- <sup>3</sup> / <sub>4</sub>	□	150	19.05	25.4	18
NDS-150- <sup>7</sup> / <sub>8</sub>	□	150	22.225	25.4	18
NDS-200- <sup>1</sup> / <sub>2</sub>	□	200	12.7	25.4	22

## ■穴径φ31.75

形番 Cat. No.	在庫 Stock	寸法 (mm) Dimensions (mm)			刃数 N
		外径 φD	刃幅 L	穴径 φd	
NDS-100-03	□	100	3	31.75	14
NDS-100-04	□	100	4	31.75	14
NDS-100-05	□	100	5	31.75	14
NDS-100-06	□	100	6	31.75	14
NDS-100-07	□	100	7	31.75	14
NDS-100-08	□	100	8	31.75	14
NDS-100-09	□	100	9	31.75	14
NDS-100-10	□	100	10	31.75	14
NDS-100-11	□	100	11	31.75	14
NDS-100-12	□	100	12	31.75	14
NDS-100-13	□	100	13	31.75	14
NDS-100-14	□	100	14	31.75	14
NDS-100-15	□	100	15	31.75	14
NDS-100-16	□	100	16	31.75	14
NDS-100-18	□	100	18	31.75	14
NDS-100-20	□	100	20	31.75	14
NDS-100-22	□	100	22	31.75	14
NDS-100-24	□	100	24	31.75	14
NDS-100-25	□	100	25	31.75	14
NDS-125-03	□	125	3	31.75	16
NDS-125-04	□	125	4	31.75	16
NDS-125-05	□	125	5	31.75	16
NDS-125-06	□	125	6	31.75	16
NDS-125-07	□	125	7	31.75	16
NDS-125-08	□	125	8	31.75	16
NDS-125-09	□	125	9	31.75	16
NDS-125-10	□	125	10	31.75	16
NDS-125-11	□	125	11	31.75	16
NDS-125-12	□	125	12	31.75	16
NDS-125-13	□	125	13	31.75	16
NDS-125-14	□	125	14	31.75	16
NDS-125-15	□	125	15	31.75	16
NDS-125-16	□	125	16	31.75	16
NDS-125-17	□	125	17	31.75	16
NDS-125-18	□	125	18	31.75	16
NDS-125-20	□	125	20	31.75	16
NDS-125-22	□	125	22	31.75	16
NDS-125-24	□	125	24	31.75	16
NDS-125-25	□	125	25	31.75	16
NDS-150-03	□	150	3	31.75	18
NDS-150-04	□	150	4	31.75	18
NDS-150-05	□	150	5	31.75	18
NDS-150-06	□	150	6	31.75	18
NDS-150-07	□	150	7	31.75	18
NDS-150-08	□	150	8	31.75	18
NDS-150-09	□	150	9	31.75	18
NDS-150-10	□	150	10	31.75	18
NDS-150-11	□	150	11	31.75	18
NDS-150-12	□	150	12	31.75	18
NDS-150-13	□	150	13	31.75	18
NDS-150-14	□	150	14	31.75	18
NDS-150-15	□	150	15	31.75	18
NDS-150-16	□	150	16	31.75	18
NDS-150-18	□	150	18	31.75	18
NDS-150-20	□	150	20	31.75	18
NDS-150-22	□	150	22	31.75	18
NDS-150-24	□	150	24	31.75	18
NDS-150-25	□	150	25	31.75	18
NDS-150-26	□	150	26	31.75	18

形番 Cat. No.	在庫 Stock	寸法 (mm) Dimensions (mm)			刃数 N
		外径 φD	刃幅 L	穴径 φd	
NDS-175-04	□	175	4	31.75	20
NDS-175-05	□	175	5	31.75	20
NDS-175-06	□	175	6	31.75	20
NDS-175-07	□	175	7	31.75	20
NDS-175-08	□	175	8	31.75	20
NDS-175-09	□	175	9	31.75	20
NDS-175-10	□	175	10	31.75	20
NDS-175-11	□	175	11	31.75	20
NDS-175-12	□	175	12	31.75	20
NDS-175-13	□	175	13	31.75	20
NDS-175-14	□	175	14	31.75	20
NDS-175-15	□	175	15	31.75	20
NDS-175-16	□	175	16	31.75	20
NDS-175-18	□	175	18	31.75	20
NDS-175-20	□	175	20	31.75	20
NDS-175-22	□	175	22	31.75	20
NDS-175-24	□	175	24	31.75	20
NDS-175-25	□	175	25	31.75	20
NDS-200-04	□	200	4	31.75	22
NDS-200-05	□	200	5	31.75	22
NDS-200-06	□	200	6	31.75	22
NDS-200-07	□	200	7	31.75	22
NDS-200-08	□	200	8	31.75	22
NDS-200-09	□	200	9	31.75	22
NDS-200-10	□	200	10	31.75	22
NDS-200-11	□	200	11	31.75	22
NDS-200-12	□	200	12	31.75	22
NDS-200-13	□	200	13	31.75	22
NDS-200-14	□	200	14	31.75	22
NDS-200-15	□	200	15	31.75	22
NDS-200-16	□	200	16	31.75	22
NDS-200-18	□	200	18	31.75	22
NDS-200-20	□	200	20	31.75	22
NDS-200-22	□	200	22	31.75	22
NDS-200-24	□	200	24	31.75	22
NDS-200-25	□	200	25	31.75	22
NDS-200-26	□	200	26	31.75	22
NDS-250-08	□	250	8	31.75	26
NDS-250-10	□	250	10	31.75	26
NDS-250-12	□	250	12	31.75	26
NDS-250-14	□	250	14	31.75	26
NDS-250-15	□	250	15	31.75	26
NDS-250-16	□	250	16	31.75	26
NDS-250-18	□	250	18	31.75	26
NDS-250-20	□	250	20	31.75	26
NDS-250-22	□	250	22	31.75	26
NDS-250-24	□	250	24	31.75	26
NDS-250-25	□	250	25	31.75	26
NDS-250-26	□	250	26	31.75	26
NDS-300-15	□	300	15	31.75	30
NDS-300-16	□	300	16	31.75	30
NDS-300-18	□	300	18	31.75	30
NDS-300-20	□	300	20	31.75	30
NDS-300-22	□	300	22	31.75	30
NDS-300-24	□	300	24	31.75	30
NDS-300-25	□	300	25	31.75	30
NDS-300-26	□	300	26	31.75	30





# 研磨丸棒チップ

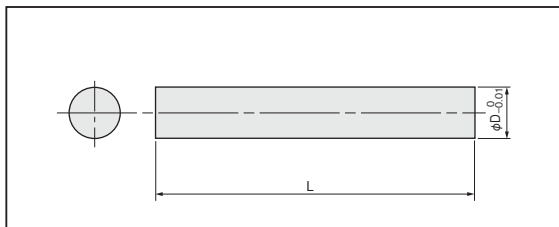

寸法 (mm)		在庫		
Dimensions (mm)		Stock		
φD	L	FB20	KG20	SRT
1.0	30	<input type="checkbox"/>	<input type="checkbox"/>	<input type="checkbox"/>
	40	<input type="checkbox"/>	<input type="checkbox"/>	<input type="checkbox"/>
	50	<input type="checkbox"/>	<input type="checkbox"/>	<input type="checkbox"/>
	60	<input type="checkbox"/>	<input type="checkbox"/>	<input type="checkbox"/>
	80			
1.5	30	<input type="checkbox"/>	<input type="checkbox"/>	<input type="checkbox"/>
	40	<input type="checkbox"/>	<input type="checkbox"/>	<input type="checkbox"/>
	50	<input type="checkbox"/>	<input type="checkbox"/>	<input type="checkbox"/>
	60	<input type="checkbox"/>	<input type="checkbox"/>	<input type="checkbox"/>
	80	<input type="checkbox"/>	<input type="checkbox"/>	<input type="checkbox"/>
2.0	30	<input type="checkbox"/>	<input type="checkbox"/>	<input type="checkbox"/>
	40	<input type="checkbox"/>	<input type="checkbox"/>	<input type="checkbox"/>
	50	<input type="checkbox"/>	<input type="checkbox"/>	<input type="checkbox"/>
	60	<input type="checkbox"/>	<input type="checkbox"/>	<input type="checkbox"/>
	80	<input type="checkbox"/>	<input type="checkbox"/>	<input type="checkbox"/>
2.5	30	<input type="checkbox"/>	<input type="checkbox"/>	<input type="checkbox"/>
	40	<input type="checkbox"/>	<input type="checkbox"/>	<input type="checkbox"/>
	50	<input type="checkbox"/>	<input type="checkbox"/>	<input type="checkbox"/>
	60	<input type="checkbox"/>	<input type="checkbox"/>	<input type="checkbox"/>
	80	<input type="checkbox"/>	<input type="checkbox"/>	<input type="checkbox"/>
3.0	30	<input type="checkbox"/>	<input type="checkbox"/>	<input type="checkbox"/>
	40	<input type="checkbox"/>	<input type="checkbox"/>	<input type="checkbox"/>
	50	<input type="checkbox"/>	<input type="checkbox"/>	<input type="checkbox"/>
	60	<input type="checkbox"/>	<input type="checkbox"/>	<input type="checkbox"/>
	80	<input type="checkbox"/>	<input type="checkbox"/>	<input type="checkbox"/>
3.5	30	<input type="checkbox"/>	<input type="checkbox"/>	<input type="checkbox"/>
	40	<input type="checkbox"/>	<input type="checkbox"/>	<input type="checkbox"/>
	50	<input type="checkbox"/>	<input type="checkbox"/>	<input type="checkbox"/>
	60	<input type="checkbox"/>	<input type="checkbox"/>	<input type="checkbox"/>
	80	<input type="checkbox"/>	<input type="checkbox"/>	<input type="checkbox"/>
4.0	30	<input type="checkbox"/>	<input type="checkbox"/>	<input type="checkbox"/>
	40	<input type="checkbox"/>	<input type="checkbox"/>	<input type="checkbox"/>
	50	<input type="checkbox"/>	<input type="checkbox"/>	<input type="checkbox"/>
	60	<input type="checkbox"/>	<input type="checkbox"/>	<input type="checkbox"/>
	80	<input type="checkbox"/>	<input type="checkbox"/>	<input type="checkbox"/>
	100	<input type="checkbox"/>	<input type="checkbox"/>	<input type="checkbox"/>
4.5	30	<input type="checkbox"/>	<input type="checkbox"/>	<input type="checkbox"/>
	40	<input type="checkbox"/>	<input type="checkbox"/>	<input type="checkbox"/>
	50	<input type="checkbox"/>	<input type="checkbox"/>	<input type="checkbox"/>
	60	<input type="checkbox"/>	<input type="checkbox"/>	<input type="checkbox"/>
	80	<input type="checkbox"/>	<input type="checkbox"/>	<input type="checkbox"/>

寸法 (mm)		在庫		
Dimensions (mm)		Stock		
φD	L	FB20	KG20	SRT
4.5	100	<input type="checkbox"/>	<input type="checkbox"/>	<input type="checkbox"/>
	30	<input type="checkbox"/>	<input type="checkbox"/>	<input type="checkbox"/>
	40	<input type="checkbox"/>	<input type="checkbox"/>	<input type="checkbox"/>
	50	<input type="checkbox"/>	<input type="checkbox"/>	<input type="checkbox"/>
	60	<input type="checkbox"/>	<input type="checkbox"/>	<input type="checkbox"/>
5.0	80	<input type="checkbox"/>	<input type="checkbox"/>	<input type="checkbox"/>
	100	<input type="checkbox"/>	<input type="checkbox"/>	<input type="checkbox"/>
	120			
	150	<input type="checkbox"/>	<input type="checkbox"/>	<input type="checkbox"/>
	200	<input type="checkbox"/>	<input type="checkbox"/>	<input type="checkbox"/>
5.5	30	<input type="checkbox"/>	<input type="checkbox"/>	<input type="checkbox"/>
	40	<input type="checkbox"/>	<input type="checkbox"/>	<input type="checkbox"/>
	50	<input type="checkbox"/>	<input type="checkbox"/>	<input type="checkbox"/>
	60	<input type="checkbox"/>	<input type="checkbox"/>	<input type="checkbox"/>
	80	<input type="checkbox"/>	<input type="checkbox"/>	<input type="checkbox"/>
	100	<input type="checkbox"/>	<input type="checkbox"/>	<input type="checkbox"/>
6.0	30	<input type="checkbox"/>	<input type="checkbox"/>	<input type="checkbox"/>
	40	<input type="checkbox"/>	<input type="checkbox"/>	<input type="checkbox"/>
	50	<input type="checkbox"/>	<input type="checkbox"/>	<input type="checkbox"/>
	60	<input type="checkbox"/>	<input type="checkbox"/>	<input type="checkbox"/>
	80	<input type="checkbox"/>	<input type="checkbox"/>	<input type="checkbox"/>
	100	<input type="checkbox"/>	<input type="checkbox"/>	<input type="checkbox"/>
6.5	120	<input type="checkbox"/>	<input type="checkbox"/>	<input type="checkbox"/>
	150	<input type="checkbox"/>	<input type="checkbox"/>	<input type="checkbox"/>
	200	<input type="checkbox"/>	<input type="checkbox"/>	<input type="checkbox"/>
	30	<input type="checkbox"/>	<input type="checkbox"/>	<input type="checkbox"/>
	40	<input type="checkbox"/>	<input type="checkbox"/>	<input type="checkbox"/>
7.0	50	<input type="checkbox"/>	<input type="checkbox"/>	<input type="checkbox"/>
	60	<input type="checkbox"/>	<input type="checkbox"/>	<input type="checkbox"/>
	80	<input type="checkbox"/>	<input type="checkbox"/>	<input type="checkbox"/>
	100	<input type="checkbox"/>	<input type="checkbox"/>	<input type="checkbox"/>
7.5	120	<input type="checkbox"/>	<input type="checkbox"/>	<input type="checkbox"/>
	150	<input type="checkbox"/>	<input type="checkbox"/>	<input type="checkbox"/>
	200	<input type="checkbox"/>	<input type="checkbox"/>	<input type="checkbox"/>
	30	<input type="checkbox"/>	<input type="checkbox"/>	<input type="checkbox"/>
	40	<input type="checkbox"/>	<input type="checkbox"/>	<input type="checkbox"/>
8.0	50	<input type="checkbox"/>	<input type="checkbox"/>	<input type="checkbox"/>
	60	<input type="checkbox"/>	<input type="checkbox"/>	<input type="checkbox"/>
	80	<input type="checkbox"/>	<input type="checkbox"/>	<input type="checkbox"/>
	100	<input type="checkbox"/>	<input type="checkbox"/>	<input type="checkbox"/>

# 研磨丸棒チップ

(前ページの続き)

寸法 (mm)		在庫		
Dimensions (mm)		Stock		
φD	L	FB20	KG20	SRT
8.0	40	<input type="checkbox"/>	<input type="checkbox"/>	
	50	<input type="checkbox"/>	<input type="checkbox"/>	<input type="checkbox"/>
	60	<input type="checkbox"/>	<input type="checkbox"/>	<input type="checkbox"/>
	80	<input type="checkbox"/>	<input type="checkbox"/>	
	100	<input type="checkbox"/>	<input type="checkbox"/>	<input type="checkbox"/>
	120		<input type="checkbox"/>	
	150		<input type="checkbox"/>	
200		<input type="checkbox"/>		
8.5	30	<input type="checkbox"/>	<input type="checkbox"/>	
	40	<input type="checkbox"/>	<input type="checkbox"/>	
	50	<input type="checkbox"/>	<input type="checkbox"/>	
	60	<input type="checkbox"/>	<input type="checkbox"/>	
	80	<input type="checkbox"/>	<input type="checkbox"/>	
	100	<input type="checkbox"/>	<input type="checkbox"/>	
9.0	30	<input type="checkbox"/>	<input type="checkbox"/>	
	40	<input type="checkbox"/>	<input type="checkbox"/>	
	50	<input type="checkbox"/>	<input type="checkbox"/>	<input type="checkbox"/>
	60	<input type="checkbox"/>	<input type="checkbox"/>	<input type="checkbox"/>
	80	<input type="checkbox"/>	<input type="checkbox"/>	
100	<input type="checkbox"/>	<input type="checkbox"/>	<input type="checkbox"/>	
9.5	30	<input type="checkbox"/>	<input type="checkbox"/>	
	40	<input type="checkbox"/>	<input type="checkbox"/>	
	50	<input type="checkbox"/>	<input type="checkbox"/>	
	60	<input type="checkbox"/>	<input type="checkbox"/>	
	80	<input type="checkbox"/>	<input type="checkbox"/>	
	100	<input type="checkbox"/>	<input type="checkbox"/>	
10.0	30	<input type="checkbox"/>	<input type="checkbox"/>	
	40	<input type="checkbox"/>	<input type="checkbox"/>	
	50	<input type="checkbox"/>	<input type="checkbox"/>	<input type="checkbox"/>
	60	<input type="checkbox"/>	<input type="checkbox"/>	<input type="checkbox"/>
	80	<input type="checkbox"/>	<input type="checkbox"/>	
	100	<input type="checkbox"/>	<input type="checkbox"/>	<input type="checkbox"/>
	120		<input type="checkbox"/>	
	150		<input type="checkbox"/>	
200		<input type="checkbox"/>		
10.5	40		<input type="checkbox"/>	
	50		<input type="checkbox"/>	
	60		<input type="checkbox"/>	
	80		<input type="checkbox"/>	
	100		<input type="checkbox"/>	
11.0	40	<input type="checkbox"/>	<input type="checkbox"/>	
	50	<input type="checkbox"/>	<input type="checkbox"/>	<input type="checkbox"/>
	60	<input type="checkbox"/>	<input type="checkbox"/>	<input type="checkbox"/>
	80	<input type="checkbox"/>	<input type="checkbox"/>	
	100	<input type="checkbox"/>	<input type="checkbox"/>	<input type="checkbox"/>
11.5	40		<input type="checkbox"/>	
	50		<input type="checkbox"/>	
	60		<input type="checkbox"/>	
	80		<input type="checkbox"/>	
100		<input type="checkbox"/>		
12.0	40	<input type="checkbox"/>	<input type="checkbox"/>	
	50	<input type="checkbox"/>	<input type="checkbox"/>	<input type="checkbox"/>
	60	<input type="checkbox"/>	<input type="checkbox"/>	<input type="checkbox"/>
	80	<input type="checkbox"/>	<input type="checkbox"/>	
	100	<input type="checkbox"/>	<input type="checkbox"/>	<input type="checkbox"/>
	120		<input type="checkbox"/>	
150		<input type="checkbox"/>		

寸法 (mm)		在庫		
Dimensions (mm)		Stock		
φD	L	FB20	KG20	SRT
12.0	200		<input type="checkbox"/>	
	50			
13.0	60	<input type="checkbox"/>	<input type="checkbox"/>	
	80	<input type="checkbox"/>	<input type="checkbox"/>	
	100	<input type="checkbox"/>	<input type="checkbox"/>	
	200			
	50			<input type="checkbox"/>
14.0	60		<input type="checkbox"/>	
	80		<input type="checkbox"/>	
	100		<input type="checkbox"/>	
	120		<input type="checkbox"/>	
	150		<input type="checkbox"/>	
200		<input type="checkbox"/>		
14.5	80			
	100			
	120			
	150			
	200			
15.0	50			
	80		<input type="checkbox"/>	
	100		<input type="checkbox"/>	
	120		<input type="checkbox"/>	
	150		<input type="checkbox"/>	
200		<input type="checkbox"/>		
16.0	80		<input type="checkbox"/>	
	100		<input type="checkbox"/>	
	120		<input type="checkbox"/>	
	150		<input type="checkbox"/>	
200		<input type="checkbox"/>		
17.0	100			
18.0	80		<input type="checkbox"/>	
	100		<input type="checkbox"/>	
	120		<input type="checkbox"/>	
	150		<input type="checkbox"/>	
	200		<input type="checkbox"/>	
19.0	100			
200				
20.0	80		<input type="checkbox"/>	
	100		<input type="checkbox"/>	
	120		<input type="checkbox"/>	
	150		<input type="checkbox"/>	
200		<input type="checkbox"/>		